

D					
C					
B					
A					
Indice Index	Data Date	Modificare Modification/Revision	Proiectant Designer	Aprobat Consultant Approved Consultant	Aprobat CFR Approved CFR



GUVERNUL ROMANIEI
ROMANIAN GOVERNMENT

PROIECT FINANȚAT DE UNIUNEA EUROPEANĂ
EUROPEAN UNION FINANCED PROJECT



C.N.C.F. "C.F.R." - S.A.

CLIENT / CLIENT



CONSULTANT / CONSULTANT

			Data Date	Semnătură Signature
Aprobat Approved	Şef proiect Project manager	R. Liuzza		
Aprobat Approved	Coordonator Secțiune 1 Section 1 Coordinator	C.Gambelli		
Verificat Checked	Tunel Expert Tunnel Expert	C. Gambelli		
Întocmit Elaborated	Proiectant Designer	C.Gambelli		

SUBCONSULTANT / SUBCONSULTANT

Aprobat Approved	Responsabil Subconsultant Subconsultant Responsible			
Întocmit Elaborated	Proiectant Designer			

Reabilitarea liniei de cale ferată Braşov - Simeria, parte componentă a coridorului IV Pan European, pentru circulația trenurilor cu viteză maximă de 160 km/h.
Secțiune 1 Brasov - Sighisoara

Proiect/Project
2004/RO/16/P/PA/003

Rehabilitation of the railway line Braşov - Simeria, component Part of the IV Pan-European Corridor, for the trains circulation with maximum speed of 160 km/h.
Section 1 Brasov - Sighisoara

Faza / Phase:
P.Th. / T.D.

Denumire desen / Drawing Title :

ORMENIS TUNEL - ORMENIS TUNELUL

Ormenis side - Technical and calculation report of provisional and definitive entrance zones structures
Zona inspre Ormenis - Raportul tehnic și calcularea intrarea provizoriei și definitive

Codificare / Codification System	Scara / Scale	LOT	Nr. / No -
----------------------------------	---------------	-----	---------------

E A 5 1 0 1 C 1 0 C L G A 0 1 0 0 0 0 1 0

Cuprins

1	INTRODUCERE	4
2	DOCUMENTE DE REFERINȚĂ.....	8
2.1	Referințe normative	8
2.2	Bibliografie.....	8
3	CARACTERIZAREA GEOTEHNICĂ A ZONEI ȘI A PROIECTULUI.....	9
3.1	Clasificarea geologică.....	9
3.2	Investigarea terenului	9
3.3	Nivelul apei.....	10
3.4	Caracterizarea parametrilor geotehnici	11
3.4.1	Parametrii fizici	11
3.4.2	Parametrii de rezistență și de deformare.....	21
3.5	Parametrii geotehnici.....	35
4	REZISTENȚA MATERIALULUI.....	36
4.1	Armături.....	36
4.2	Beton.....	36
5	CRITERIILE DE PROIECTARE ȘI ANALIZA STRUCTURILOR TEMPORARE	37
5.1	Descrierea structurilor temporare pentru intrarea tunelului	37
5.2	Criteriile de proiectare	38
5.2.1	Stările limită extreme	38
5.2.2	Stările limită de deservire.....	40
5.2.3	Metoda de calcul	41
5.3	Cazuri analizate și rezultate.....	42
5.3.1	Secțiuni reprezentative	42
5.3.2	Date de intrare pentru analiză.....	44
5.3.3	Rezultatele analizelor	45
5.3.3.1	Secțiunea 1 (Combinăția GEO).....	46
5.3.3.2	Secțiunea 1 (Combinăția STR).....	48
5.3.3.3	Secțiunea 2 (Combinăția GEO).....	50
5.3.3.4	Secțiunea 2 (Combinăția STR).....	52
5.3.3.5	Secțiunea 3 (Combinăția GEO).....	54
5.3.3.6	Secțiunea 3 (Combinăția STR).....	56
5.3.4	Verificarea rezistenței elementelor structurale	58
5.3.4.1	Piloni.....	58

5.3.4.2	Picioarele de reazem	60
5.3.5	Proiectarea ancorelor	64
6	CRITERIILE DE PROIECTARE ȘI ANALIZA STRUCTURILOR PERMANENTE	68
6.1	Descrierea structurilor permanente pentru intrarea tunelului.....	68
6.2	Criteriile de proiectare	68
6.3	Cazurile de sarcină.....	69
6.3.1.	Sarcini verticale	69
6.3.2.	Sarcini orizontale	69
6.3.3.	Sarcini seismice.....	70
6.3.4.	Presiunile seismice ale pământului (Mononobe–Okabe).....	70
6.4.	Caracterizarea materialului și criteriul de verificare.....	73
6.4.1.	Starea limită extremă	73
6.4.2.	Starea limită de deservire	74
6.5.	Metoda de calcul	75
6.6.	Cazuri analizate.....	76
6.7.	Rezultatele analizei	78
6.8.	Verificări structurale ULS	90
6.9.	Verificări SLS.....	97
7.	CONCLUZII	99

Anexa 1 Excavarea STR A1+M1+R1 L= 7.5 m

Anexa 2 Excavarea STR A1+M1+R1 L= 9.5 m

Anexa 3 Excavarea STR A1+M1+R1 L= 15.3 m

Anexa 4 SAP 2000 – Ormenis static

Anexa 5 SAP 2000 – Ormenis seismic

1 INTRODUCERE

În acest raport ne ocupăm cu problemele de proiectare referitoare la lucrările de construcții pe latura Ormenis a Tunelului Ormenis de-a lungul aliniamentului de cale ferată Brașov – Simeria (Secțiunea 1 Brașov – Sighisoara) ce aparține rețelei de căi ferate ale Coridorului IV Pan European.

Tunelul este un tunel de cale ferată cu două sensuri, format din două conducte diferite situate la o distanță de aproximativ 30 m. Cele două zone de intrare diferită sunt formate pentru fiecare conductă din părți artificiale cu porți de intrare de forma unui „canal fracționat”

Tunelul Ormenis este compus din următoarele lucrări de construcții (structuri permanente):

	LATURA ORMENIS			LATURA RACOS		
	CANAL	TUNEL ARTIFICIAL	TUNEL NATURAL		TUNEL ARTIFICIAL	CANAL
	pk	pk	de la pk	la pk	pk	pk
LINIA 1 ORMENIS	213.158,38	213.173,38	213.210,10	220.024,46	220.057,35	220.072,35
LINIA 2 ORMENIS	213.136,17	213.151,17	213.187,89	219.999,25	220.038,84	220.053,84

	LATURA ORMENIS			LATURA RACOS		
	CANAL	TUNEL ARTIFICIAL	TUNEL NATURAL		TUNEL ARTIFICIAL	CANAL
	L (m)	L (m)	L (m)		L (m)	L (m)
LINIA 1 ORMENIS	15,00	36,72	6.814,36		32,89	15,00
LINIA 2 ORMENIS	15,00	36,72	6.811,36		39,59	15,00

REHABILITATION OF THE RAILWAY LINE BRASOV – SIMERIA, COMPONENT PART OF IV PAN-EUROPEAN CORRIDOR FOR THE TRAINS CIRCULATION WITH MAXIMUM SPEED OF 160 KM/H.

Pământul este excavat la adâncimea cerută cu ziduri de sprijin ancorate care suportă solul pe laturi. Zidurile de sprijin sunt constituite din piloni din beton armat în timp ce ancorele sunt pe 4 nivele (adâncime maximă) de extradrosuri de legătură cimentate.

În secțiunile următoare ale acestui document sunt definiți parametrii geotehnici ai proiectului iar apoi sunt prezentate analizele pentru a verifica gradul de adecvare a proiectării statice pentru structurile temporare și pentru structurile permanente.

REHABILITATION OF THE RAILWAY LINE BRASOV – SIMERIA, COMPONENT PART OF IV PAN-EUROPEAN CORRIDOR FOR THE TRAINS CIRCULATION WITH MAXIMUM SPEED OF 160 KM/H.

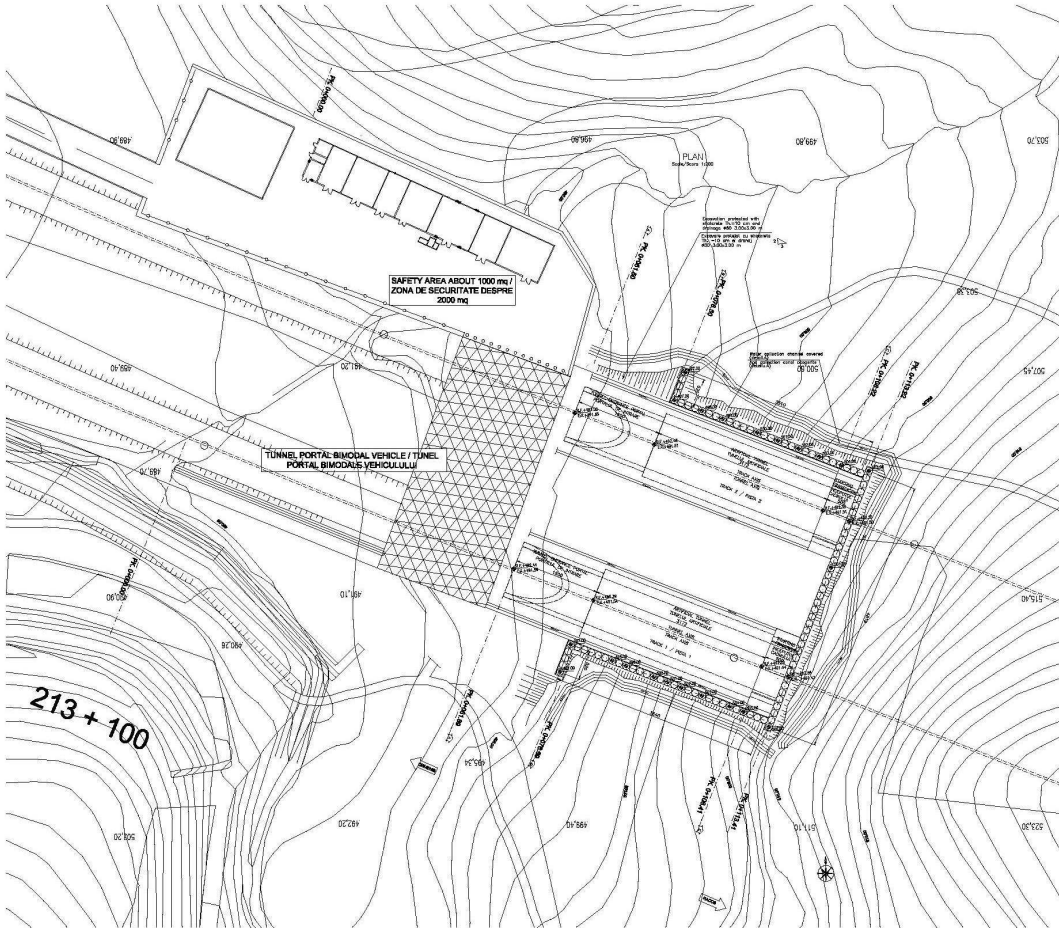

SECTION 1-1
SECTIONA 1-1
Scale 1:200

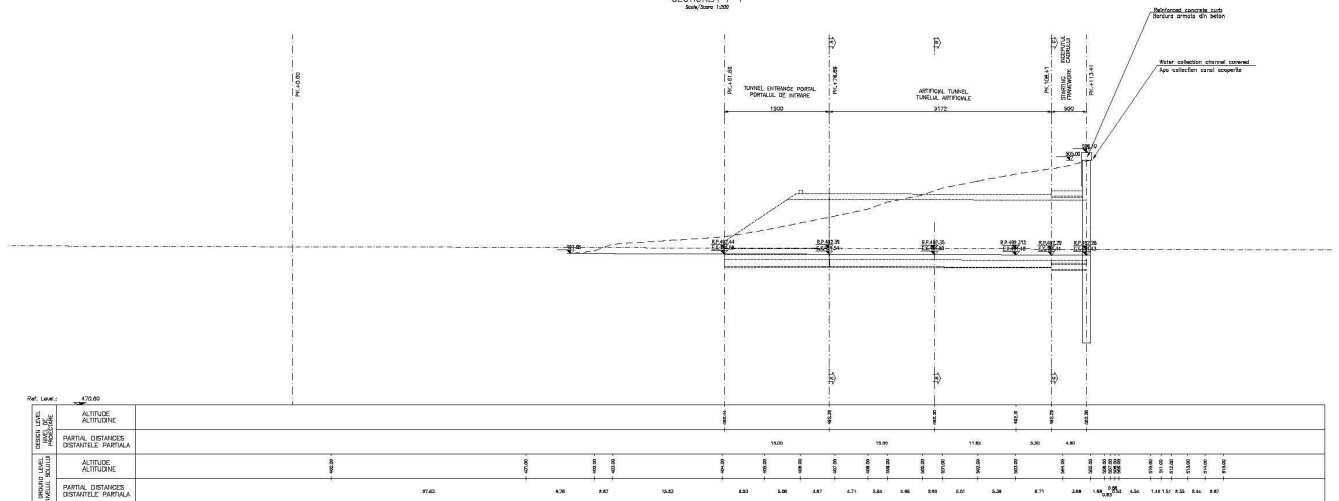

Ref. Level: ± 270.60

STATIONING	PARTIAL DISTANCES		DISTANCE	PARTIAL DISTANCES		DISTANCE	PARTIAL DISTANCES		DISTANCE	PARTIAL DISTANCES		DISTANCE	PARTIAL DISTANCES		DISTANCE
	ALTIMETRIC	GRADIENT		ALTIMETRIC	GRADIENT		ALTIMETRIC	GRADIENT		ALTIMETRIC	GRADIENT		ALTIMETRIC	GRADIENT	
2130.00	0.00	0.00	13.00	0.00	0.00	13.00	0.00	0.00	13.00	0.00	0.00	13.00	0.00	0.00	13.00
2131.00	0.00	0.00	12.00	0.00	0.00	12.00	0.00	0.00	12.00	0.00	0.00	12.00	0.00	0.00	12.00
2132.00	0.00	0.00	11.00	0.00	0.00	11.00	0.00	0.00	11.00	0.00	0.00	11.00	0.00	0.00	11.00
2133.00	0.00	0.00	10.00	0.00	0.00	10.00	0.00	0.00	10.00	0.00	0.00	10.00	0.00	0.00	10.00
2134.00	0.00	0.00	9.00	0.00	0.00	9.00	0.00	0.00	9.00	0.00	0.00	9.00	0.00	0.00	9.00
2135.00	0.00	0.00	8.00	0.00	0.00	8.00	0.00	0.00	8.00	0.00	0.00	8.00	0.00	0.00	8.00
2136.00	0.00	0.00	7.00	0.00	0.00	7.00	0.00	0.00	7.00	0.00	0.00	7.00	0.00	0.00	7.00
2137.00	0.00	0.00	6.00	0.00	0.00	6.00	0.00	0.00	6.00	0.00	0.00	6.00	0.00	0.00	6.00
2138.00	0.00	0.00	5.00	0.00	0.00	5.00	0.00	0.00	5.00	0.00	0.00	5.00	0.00	0.00	5.00
2139.00	0.00	0.00	4.00	0.00	0.00	4.00	0.00	0.00	4.00	0.00	0.00	4.00	0.00	0.00	4.00
2140.00	0.00	0.00	3.00	0.00	0.00	3.00	0.00	0.00	3.00	0.00	0.00	3.00	0.00	0.00	3.00
2141.00	0.00	0.00	2.00	0.00	0.00	2.00	0.00	0.00	2.00	0.00	0.00	2.00	0.00	0.00	2.00
2142.00	0.00	0.00	1.00	0.00	0.00	1.00	0.00	0.00	1.00	0.00	0.00	1.00	0.00	0.00	1.00
2143.00	0.00	0.00	0.00	0.00	0.00	0.00	0.00	0.00	0.00	0.00	0.00	0.00	0.00	0.00	0.00

REHABILITATION OF THE RAILWAY LINE BRASOV – SIMERIA, COMPONENT PART OF IV PAN-EUROPEAN CORRIDOR FOR THE TRAINS CIRCULATION WITH MAXIMUM SPEED OF 160 KM/H.

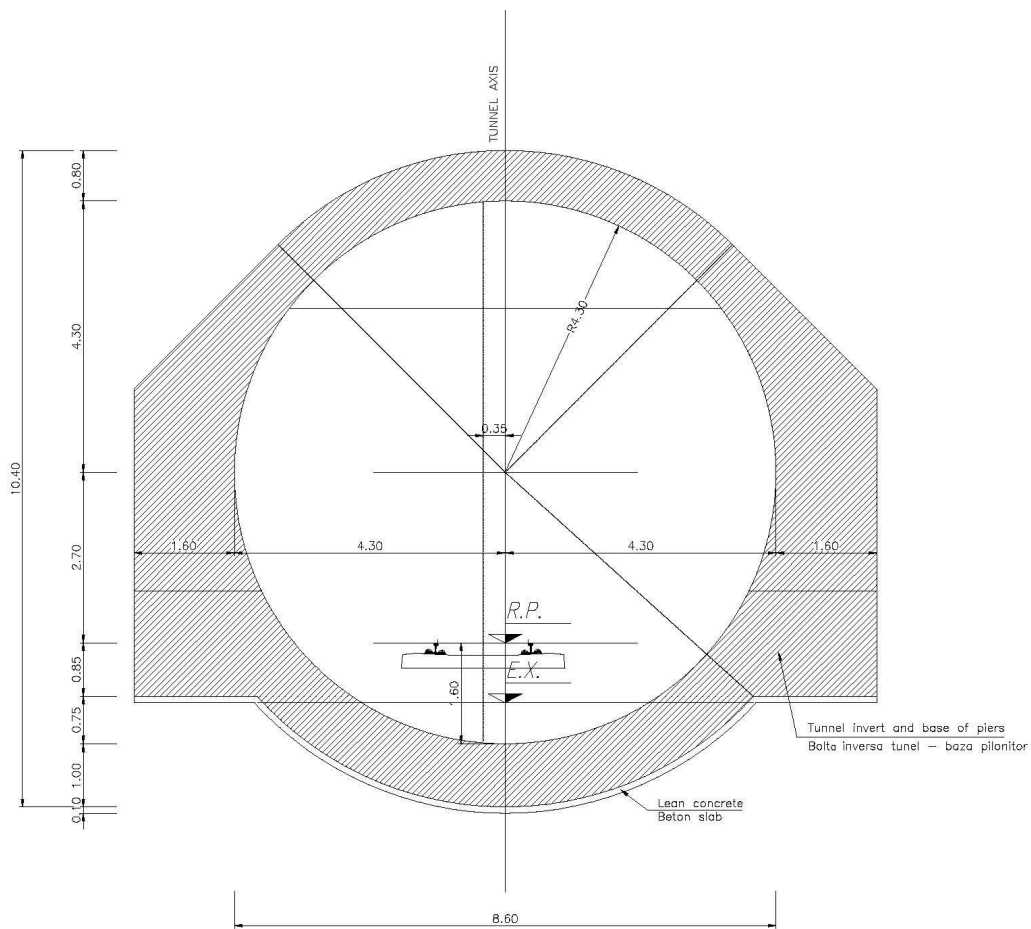
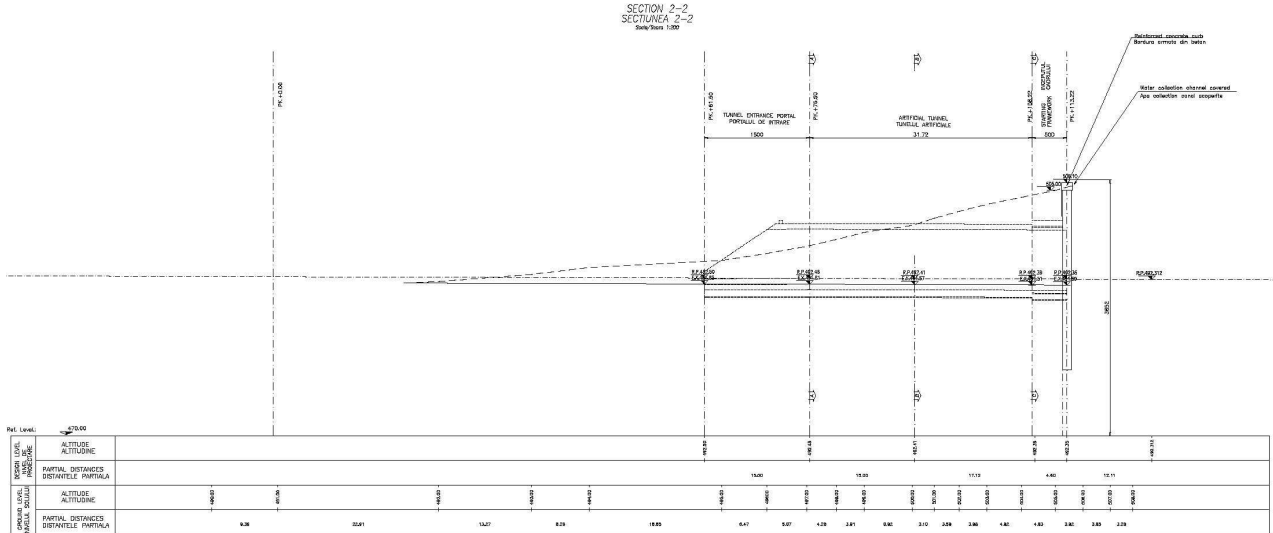

2 DOCUMENTE DE REFERINȚĂ

2.1 Referințe normative

- [A] EN 1990:2002 – Eurocod: Baza proiectării structurale.
- [B] EN 1991 – Eurocod 1: Acțiuni pe structuri.
- [C] EN 1992 – Eurocod 2: Proiectarea structurilor din beton.
- [D] EN 1993 – Eurocod 3: Proiectarea structurilor din oțel.
- [E] EN 1997-1 – Eurocod 7: Proiectul geotehnic – Partea 1: Reguli generale.
- [F] EN 1997-2 – Eurocod 7: Proiectul geotehnic – Partea 2: Investigarea și testarea terenului.
- [G] EN 1998 – Eurocod 8: Proiectarea structurilor pentru rezistența la cutremur.

2.2 Bibliografie

- [H] Bowles (1998) – Analiza și proiectarea fundațiilor, Ediția 4, McGraw-Hill, Inc.
- [J] Ce.A.S (2008) – Manualul de program Paratie.

3 CARACTERIZAREA GEOTEHNICĂ A ZONEI ȘI A PROIECTULUI

În această secțiune sunt descrise caracteristicile geologice și geotehnice ale zonei și parametrii geotehnici ai proiectului cu referiri la investigarea terenului.

3.1 Clasificarea geologică

Reconstituirea geologică a zonei de intrare indică că tunelul traversează următoarele unități litologice:

- Soluri coezive (argile, argile prăfoase, argile nisipoase) cu fragmente de roci gălbui unghiulare, din era Cuaternară; urmate de un compus marnos gri format din argile marnoase prăfoase și argile prăfoase nisipoase marnoase, din Cretacic (Vraconian – Turonian).
- Sedimente cuaternare formate din argile, argile prăfoase, argile nisipoase, nisip argilos cu pietriș, pietriș gălbui și brun cu nisip argilos; urmate de un compus marnos gri din Perioada Miocenului Superior.

3.2 Investigarea terenului

Investigarea terenului, efectuată de-a lungul aliniamentului Brasov- Sighisoara unde este inserat tunelul Ormenis, a permis să se obțină informațiile geologice și geotehnice pentru proiectarea lucrărilor de construcții și de asemenea să se definească caracteristicile fizice și mecanice ale solurilor prin teste de laborator efectuate pe mai multe probe extrase. Investigațiile de teren de-a lungul aliniamentului au fost efectuate pentru a defini caracteristicile de deformabilitate și permeabilitate ale solurilor. Forajele au fost făcute cu un diametru de foraj (100 mm) și executate la o adâncime maximă de 30 m.

Investigarea de teren, în cadrul zonei unde va fi excavata intrare în tuneluri, constă din:

- RAO F1 30m adâncime

REHABILITATION OF THE RAILWAY LINE BRASOV – SIMERIA, COMPONENT PART OF IV PAN-EUROPEAN CORRIDOR FOR THE TRAINS CIRCULATION WITH MAXIMUM SPEED OF 160 KM/H.

- RAO F2 30m adâncime
- RAO F3 30m adâncime

Pentru a avea o caracterizare mai detaliată a materialelor vor fi luate în considerare și rezultatele testelor de laborator făcute pe probe luate din investigații care nu se încadrează strict în zona de intrare a tunelului. Totuși acestea vor furniza informații utile pentru definirea parametrilor diferitelor formațiuni.

Control	Adâncime	Probe deranjate	Probe nederanjate	Teste SPT	Teste Menard	Test Lefranc	Nivel Piezometric
RAO F1	30	5	1	6	1		
RAO F2	30	6	1	3	1		
RAO F3	30	5	2	6	1		
RAO F5	26	2	4	5	2		
RAO F6	30	5	1	4	2		-1.14 m
RAO F7	30	7	4	10		1	
RAO F8 BIS	50	12	7	19	1	2	
RAO F10	40	15	1	12		1	
RAO F11	30	2	10	10			-0.5
RAO F12	42	9	3	11			
RAO F13	42	14	2	15	1		

3.3 Nivelul apei

Unele găuri de foraj executate în zona de investigare au fost prevăzute și cu piezometru iar intervalul de variație a nivelului apei este de cca 0.5 ÷ 1.14 m. Prin urmare excavația va fi considerată în apa subterană.

REHABILITATION OF THE RAILWAY LINE BRASOV – SIMERIA, COMPONENT PART OF IV PAN-EUROPEAN CORRIDOR FOR THE TRAINS CIRCULATION WITH MAXIMUM SPEED OF 160 KM/H.

3.4 Caracterizarea parametrilor geotehnici

Aceste depozite constau în argilă și argile nisipoase. În general, caracterizarea acestor depozite este rezultatul din analiza testărilor de laborator, a căror CU triaxial a fost efectuat pe probe nederanjate, și din testarea in situ. Rezultatele testării sunt sintetizate în tabele.

3.4.1 Parametrii fizici

RAO F1

Faza Etichetă	Numărul probei Number of sample	Adâncimea probei Depth of sample [m]	Parametrii fizici																		
			Argilă conținută < 0,002 mm Coloidal clay [%]	Argilă < 0,005 mm Clay [%]	Pier 0,005-0,05 mm Silt [%]	Nisip 0,05-2,00 mm Sand [%]	Pleing 2-70 mm Gravel [%]	Bolovăniș 70-200 mm Cobbles [%]	Grad de neuniformitate Non uniformity [Un]	Umiditatea naturală (w) Water content [%]	Limita superioară de plasticitate (Ip) Liquid limit [%]	Limita inferioară de plasticitate (Ip) Plastic limit [%]	Indicele de plasticitate (Ip) Plasticity index [%]	Indicele de consistență (Ic) Consistency index [%]	Umiditatea (w) Water content [%]	Densitatea scheletului mineral (ρs) Specific density [t/m ³]	Densitatea naturală (ρ) Bulk density [t/m ³]	Densitatea stare uscată (ρd) Dry density [t/m ³]	Porozitatea (n) Porosity [%]	Indicele pomier (e) Void ratio	Gradul de umiditate (S) Saturation ratio [%]
RAOF1PNT1	4.30-4.80		32,4	16,1	40,5	10,0	1,0	0,0		18,53	47,8	22,5	25,2	1,16	18,53	25,82	20,22	17,06	33,93	0,51	95,0
RAOF1PT2	7.10-7.50		15,7	10,8	19,9	28,2	25,4	0,0			30,3	14,3	16,0			25,77					
RAOF1PT3	12.04-12.40		23,6	14,9	37,4	16,7	7,4	0,0			53,0	26,2	26,8			25,86					
RAOF1PT4	18.00-18.50		21,1	14,9	50,4	11,6	2,0	0,0			46,4	23,2	25,2			26,03					
RAOF1PT5	24.60-25.00		20,1	10,2	34,7	22,7	12,3	0,0			37,3	17,3	20,0			26,08					
RAOF1PT6	29.80-29.90		16,8	13,7	34,7	18,9	16,1	0,0			37,3	18,2	19,1			26,01					

REHABILITATION OF THE RAILWAY LINE BRASOV – SIMERIA, COMPONENT PART OF IV PAN-EUROPEAN CORRIDOR FOR THE TRAINS CIRCULATION WITH MAXIMUM SPEED OF 160 KM/H.

RAO F2

Faza Bottle	Numărul probei Number of sample	Adâncimea probei Depth of sample [m]	RAO F2																		
			Argilă coloidală <0,002 mm Colloidal clay [%]	Argilă <0,005 mm Clay [%]	Frați 0,005-0,06 mm Silt [%]	Nisip 0,06-2,00 mm Sand [%]	Pietriș 2-70 mm Gravel [%]	Bolivâniș 70-200 mm Cobble [%]	Grad de neuniformitate Non uniformity [μm]	Umiditatea naturală (w) Water content [%]	Limita superioară de plasticitate (ψ) Liquid limit [%]	Limita inferioară de plasticitate (ψ) Plastic limit [%]	Indicele de plasticitate (I _p) Plasticity index [%]	Indicele de consistență (I _c) Consistency index [%]	Umiditatea (w) Water content [%]	Densitatea scheletului mineral (ρ _s) Skeletal density [t/m ³]	Densitatea naturală (ρ) Bulk density [t/m ³]	Densitatea stare uscată (ρ _d) Dry density [t/m ³]	Porozitatea (n) Porosity [%]	Indicele ponilor (e) Void ratio	Gradul de umiditate (S) Saturation ratio [%]
RAOF2PT1	2,00-2,40		30,7	12,2	31,2	24,4	1,5	0,0		46,80	81,8	25,7	35,9	0,42	46,80	25,91	18,90	11,53	55,50	1,25	98,7
RAOF2PT2	33,10-3,40		22,8	8,0	24,3	39,7	5,4	0,0			39,6	18,3	21,3			26,09					
RAOF2PT3	6,60-6,90		18,3	17,5	45,2	16,6	2,4	0,0			35,9	16,2	19,7			25,97					
RAOF2PT4	14,50-14,99		15,3	16,4	45,8	20,1	2,4	0,0			34,0	15,4	18,6			25,91					
RAOF2PT5	19,70-20,00		17,1	16,8	44,2	9,2	12,7	0,0			34,8	17,3	17,5			26,11					
RAOF2PT6	25,70-26,00		18,8	19,8	51,4	9,4	0,6	0,0			35,3	18,3	19,0			25,99					
RAOF2PT7	29,70-30,00		16,4	18,9	60,3	4,4	0,0	0,0			37,0	18,3	18,7			25,81					

REHABILITATION OF THE RAILWAY LINE BRASOV – SIMERIA, COMPONENT PART OF IV PAN-EUROPEAN CORRIDOR FOR THE TRAINS CIRCULATION WITH MAXIMUM SPEED OF 160 KM/H.

RAO F3

FORULI Formule	Numărul probei Number of sample	Adâncimea probei Depth of sample [m]	RAO F3																		
			Argilă coloidală < 0,002 mm Colloidal clay [%]	Argilă < 0,005 mm Clay [%]	Praf 0,005-0,05 mm Silt [%]	Nisip 0,05-2,00 mm Sand [%]	Pietriș 2-70 mm Gravel [%]	Bolovaniș 70-200 mm Cobble [%]	Grad de neuniformitate Non uniformity [Un]	Umiditatea naturală (w) Water content [%]	Limita superioară de plasticitate (p) Liquid limit [%]	Limita inferioară de plasticitate (p) Plastic limit [%]	Indicele de plasticitate (p) Plasticity index [%]	Indicele de consistență (I) Consistency index [%]	Umiditatea (w) Water content [%]	Densitatea scheletului mineral (ρ _s) Specific density [t/m ³]	Densitatea naturală (ρ) Bulk density [t/m ³]	Densitatea stare uscată (ρ _d) Dry density [t/m ³]	Porozitatea (n) Porosity [%]	Indicele porilor (e) Void ratio	Gradul de umiditate (S) Saturation ratio [%]
RAO F3	RAOF3PNT1	1,20-1,70	19,1	15,1	35,5	28,1	2,2	0,0		20,50	42,0	18,4	23,6	0,91	20,50	25,91	19,52	16,20	37,48	0,60	90,4
	RAOF3PT2	6,60-7,00	21,5	16,4	42,4	10,7	9,0	0,0			39,5	18,3	21,2			25,86					
	RAOF3PT3	11,00-11,40	18,7	19,5	53,5	4,6	3,7	0,0	8,4		42,1	20,3	21,8			25,84					
	RAOF3PT4	17,60-18,00	23,9	19,8	46,2	6,9	3,2	0,0			41,8	19,2	22,5			26,01					
	RAOF3PT5	22,60-23,00	28,8	18,5	47,0	5,6	0,1	0,0			51,7	25,1	26,5			26,10					
	RAOF3PT6	28,60-29,00																			
RAO F3	RAOF3PNT1	1,20-1,70	19,1	15,1	35,5	28,1	2,2	0,0		20,50	42,0	18,4	23,6	0,91	20,50	25,91	19,52	16,20	37,48	0,60	90,4
	RAOF3PT2	6,60-7,00	21,5	16,4	42,4	10,7	9,0	0,0			39,5	18,3	21,2			25,86					
	RAOF3PT3	11,00-11,40	18,7	19,5	53,5	4,6	3,7	0,0	8,4		42,1	20,3	21,8			25,84					
	RAOF3PT4	17,60-18,00	23,9	19,8	46,2	6,9	3,2	0,0			41,8	19,2	22,5			26,01					
	RAOF3PT5	22,60-23,00	28,8	18,5	47,0	5,6	0,1	0,0			51,7	25,1	26,5			26,10					
	RAOF3PT6	28,60-29,00																			

REHABILITATION OF THE RAILWAY LINE BRASOV – SIMERIA, COMPONENT PART OF IV PAN-EUROPEAN CORRIDOR FOR THE TRAINS CIRCULATION WITH MAXIMUM SPEED OF 160 KM/H.

RAO F5

Porajul Pothole	Numărul probei Number of sample	Adâncimea probei Depth of sample [m]	Argilă coloidală <0.002 mm	Argilă < 0.005 mm	Praf 0.005-0.05 mm	Nisip 0.05-2.00 mm	Pietriș 2-70 mm	Bolovași 70-200 mm	Grad de neuniformitate	Umiditatea naturală (w)	Limita superioară de plasticitate (p)	Limita inferioară de plasticitate (y)	Indicele de plasticitate (p)	Indicele de consistență (I)	Umiditatea (w)	Densitatea scheletului mineral (ρ _s)	Densitatea naturală (ρ)	Densitatea stare uscată (ρ _d)	Porozitatea (n)	Indicele ponior (e)	Gradul de umiditate (S)
			Colloidal clay [%]	Clay [%]	Silt [%]	Sand [%]	Gravel [%]	Cobble [%]	Non uniformity [Un]	Water content [%]	Liquid limit [%]	Plastic limit [%]	Plasticity index [%]	Consistency index [%]	Water content [%]	Specific density [t/m ³]	Bulk density [t/m ³]	Dry density [t/m ³]	Porosity [%]	Void ratio	Saturation ratio [%]
RAOF5NT1	2,00-2,50		16,9	14,4	46,0	22,2	0,5	0,0		23,01	40,3	20,1	20,2	0,86	23,01	25,88	18,88	15,35	40,70	0,69	88,5
RAOF5T2	5,50-5,80		22,3	15,1	42,8	15,7	4,1	0,0			36,0	16,3	19,7			25,84					
RAOF5T3	11,00-11,50		22,7	18,9	45,7	11,8	0,9	0,0			41,1	19,3	21,8			25,93					
RAOF5NT4	17,50-18,00		36,4	17,4	36,9	7,1	0,2	0,0		12,51	56,7	19,4	37,3	1,18	12,51	25,80	21,60	19,20	25,80	0,34	95,7
RAOF5NT5	23,00-23,50		34,7	21,3	41,1	2,7	0,2	0,0		10,27	57,6	20,2	37,4	1,27	10,27	25,78	21,98	19,91	22,75	0,29	91,6
RAOF5NT6	26,00-26,50		36,2	17,6	40,6	4,3	1,1	0,0		11,82	55,5	19,1	36,4	1,21	11,82	25,89	21,51	19,28	25,23	0,34	90,5

RAO F6

Porajul Pothole	Numărul probei Number of sample	Adâncimea probei Depth of sample [m]	Argilă coloidală <0.002 mm	Argilă < 0.005 mm	Praf 0.005-0.05 mm	Nisip 0.05-2.00 mm	Pietriș 2-70 mm	Bolovași 70-200 mm	Grad de neuniformitate	Umiditatea naturală (w)	Limita superioară de plasticitate (p)	Limita inferioară de plasticitate (y)	Indicele de plasticitate (p)	Indicele de consistență (I)	Umiditatea (w)	Densitatea scheletului mineral (ρ _s)	Densitatea naturală (ρ)	Densitatea stare uscată (ρ _d)	Porozitatea (n)	Indicele ponior (e)	Gradul de umiditate (S)
			Colloidal clay [%]	Clay [%]	Silt [%]	Sand [%]	Gravel [%]	Cobble [%]	Non uniformity [Un]	Water content [%]	Liquid limit [%]	Plastic limit [%]	Plasticity index [%]	Consistency index [%]	Water content [%]	Specific density [t/m ³]	Bulk density [t/m ³]	Dry density [t/m ³]	Porosity [%]	Void ratio	Saturation ratio [%]
RAOF6NT1	2,00-2,50		19,6	16,3	43,3	17,9	0,7	0,0		20,55	43,6	19,3	24,5	0,95	20,55	25,69	20,10	16,67	35,09	0,54	99,6
RAOF6T2	8,00-8,50		10,7	6,8	17,1	24,4	41,0	0,0			22,7	11,3	11,4			25,93					
RAOF6T3	12,00-12,50		10,1	11,0	37,3	31,0	10,6	0,0			26,1	12,4	13,7			26,07					
RAOF6T4	18,00-18,50		13,4	13,8	45,1	26,6	1,1	0,0			30,6	14,3	16,3			25,90					
RAOF6T5	24,50-25,00		13,6	13,8	43,1	20,2	9,3	0,0			31,1	14,3	16,8			25,83					
RAOF6T6	29,50-30,00		23,0	16,6	49,2	9,4	1,8	0,0			41,6	18,4	23,2			25,97					

REHABILITATION OF THE RAILWAY LINE BRASOV – SIMERIA, COMPONENT PART OF IV PAN-EUROPEAN CORRIDOR FOR THE TRAINS CIRCULATION WITH MAXIMUM SPEED OF 160 KM/H.

RAO F7

Forajul Borobulă	Numărul probei Number of sample	Adâncimea probei Depth of sample [m]	RAO F7																		
			Argilă coloidală <0.002 mm Colloidal clay [%]	Argilă <0.005 mm Clay [%]	Frație 0.005-0.05 mm Silt [%]	Nisip 0.05-2.00 mm Sand [%]	Piergiș 2-70 mm Gravel [%]	Bolovaniș 70-200 mm Cobble [%]	Grad de neuniformitate Non uniformity [Un]	Umiditatea naturală (w) Water content [%]	Limita superioară de plasticitate (w) Liquid limit [%]	Limita inferioară de plasticitate (w) Plastic limit [%]	Indicele de plasticitate (Ip) Plasticity index [%]	Indicele de consistență (Ic) Consistency index [%]	Umiditatea (w) Water content [%]	Densitatea scheletului mineral (ρs) Specific density [t/m ³]	Densitatea naturală (ρ) Bulk density [t/m ³]	Densitatea stare uscată (ρs) Dry density [t/m ³]	Porozitatea (n) Porosity [%]	Indicele ponilor (e) Void ratio	Gradul de umiditate (S) Saturation ratio [%]
RAOF7NT1	1.00-1.50		27,6	12,9	38,3	21,2	0,0	0,0		29,10	48,3	21,6	26,6	0,72	29,10	25,50	18,53	14,35	43,71	0,78	97,4
RAOF7NT2	4.00-4.50		6,6	5,4	48,0	39,8	0,0	0,0		27,60	32,6	14,2	18,3	0,27	27,60	26,20	19,22	15,08	42,50	0,74	99,7
RAOF7NT3	6.00-6.50		15,9	15,6	53,6	12,7	2,2	0,0	13	15,06	48,8	20,8	28,1	1,20	15,06	26,03	21,13	18,37	29,42	0,42	95,9
RAOF7NT4	9.00-9.50		15,7	19,2	48,3	11,9	4,9	0,0	13	11,48	45,9	20,7	25,1	1,37	11,48	26,13	21,37	19,17	26,63	0,36	84,2
RAOF7T5	11.50-12.00		25,6	14,2	46,1	9,2	4,9	0,0			42,6	18,2	24,3	0,00		26,23					
RAOF7T6	14.00-14.50		28,3	15,8	48,8	5,9	1,2	0,0			43,8	20,3	23,5	0,00		26,33					
RAOF7T9	21.00-21.50		28,3	14,6	49,3	6,1	1,7	0,0			44,2	18,2	26,0	0,00		26,45					
RAOF7T10	24.00-24.50		27,6	13,9	51,2	7,3	0,0	0,0			45,5	20,0	25,5	0,00		26,46					
RAOF7T11	28.00-28.45		25,9	14,6	48,8	10,7	0,0	0,0			41,8	18,5	23,3	0,00		26,34					

REHABILITATION OF THE RAILWAY LINE BRASOV – SIMERIA, COMPONENT PART OF IV PAN-EUROPEAN CORRIDOR FOR THE TRAINS CIRCULATION WITH MAXIMUM SPEED OF 160 KM/H.

RAO F8BIS

Proieciul Ecartula	Numărul probei Number of sample	Adâncimea probei Depth of sample [m]	RAO F8 B IS																		
			Argilă coloidală < 0,002 mm Colloidal clay [%]	Argilă < 0,005 mm Clay [%]	Praf 0,005-0,06 mm Silt [%]	Nisip 0,06-2,00 mm Sand [%]	Pietriș 2-70 mm Gravel [%]	Bolovaș 70-200 mm Cobble [%]	Grad de neuniformitate Non uniformity [Un]	Umiditatea naturală (w) Water content [%]	Limita superioară de plasticitate (p) Liquid limit [%]	Limita inferioară de plasticitate (pk) Plastic limit [%]	Indicele de plasticitate (I) Plasticity index [%]	Indicele de consistență (Ic) Consistency index [%]	Umiditatea (w) Water content [%]	Densitatea scheletului mineral (ρs) Specific density [t/m ³]	Densitatea naturală (ρ) Bulk density [t/m ³]	Densitatea stare uscată (ρd) Dry density [t/m ³]	Porozitatea (n) Porosity [%]	Indicele porilor (e) Void ratio	Gradul de umiditate (S) Saturation ratio [%]
RAOF8BIS NT1		1.00 - 1.50	26,9	13,4	48,0	11,7	0,0	0,0		21,75	40,6	17,9	22,7	0,83	21,75	25,84	19,23	15,78	38,91	0,64	90,0
RAOF8BIS T2		3.00 - 3.40	19,5	11,5	34,9	33,4	0,7	0,0			30,5	12,7	17,8			25,80					
RAOF8BIS T3		6.00 - 6.40	13,2	8,0	24,9	33,4	20,5	0,0			21,4	10,4	11,0			26,03					
RAOF8BIS T4		8.45 - 8.70	16,1	13,2	26,8	35,9	8,0	0,0			32,5	14,7	17,8			26,11					
RAOF8BIS T5		11.00 - 11.40	23,2	13,1	42,2	10,8	10,7	0,0			39,5	15,1	24,4			25,93					
RAOF8BIS T6		14.00 - 14.40	27,3	16,1	44,2	11,4	1,0	0,0			48,2	18,5	29,7			25,80					
RAOF8BIS T7		16.00 - 16.45	36,3	18,6	39,5	4,1	1,5	0,0			57,4	20,2	37,2			25,72					
RAOF8BIS T8		19.45 - 19.90	29,8	14,8	47,6	7,6	0,2	0,0			48,6	20,5	28,1			25,81					
RAOF8BIS T9		21.65 - 22.00	21,0	12,9	36,1	27,1	2,9	0,0			39,0	16,9	22,1			25,98					
RAOF8BIS T10		24.00 - 24.45	20,0	14,9	40,5	22,9	1,7	0,0			37,6	17,6	20,0			25,95					
RAOF8BIS T11		26.80 - 27.00	23,7	15,8	44,4	15,6	0,5	0,0			43,0	17,8	25,2			25,88					
RAOF8BIS T12		31.00 - 31.40	14,6	9,5	30,8	22,4	22,7	0,0			26,9	12,6	14,4			25,92					
RAOF8BIS T13		34.40 - 34.85	16,1	11,2	34,7	22,6	15,4	0,0			36,4	19,8	16,6			25,91					
RAOF8BIS NT14		36.00 - 36.50	28,4	28,7	31,4	9,5	2,0	0,0		13,46	42,0	20,2	21,8	1,31	13,46	26,03	21,63	19,06	26,76	0,37	97,6

REHABILITATION OF THE RAILWAY LINE BRASOV – SIMERIA, COMPONENT PART OF IV PAN-EUROPEAN CORRIDOR FOR THE TRAINS CIRCULATION WITH MAXIMUM SPEED OF 160 KM/H.

RAO F10

Profil Bottle		Numărul probei Number of sample	Adâncimea probei Depth of sample [m]	Argilă coloidală < 0,002 mm Colloidal clay [%]	Argilă < 0,005 mm Clay [%]	Praf 0,005-0,05 mm Silt [%]	Nisip 0,05-2,00 mm Sand [%]	Pleavă 2-70 mm Gravel [%]	Bolovani 70-200 mm Cobble [%]	Grad de neuniformitate Non uniformity [UI]	Umiditatea naturală (w) Water content [%]	Limita superioară de plasticitate (w) Liquid limit [%]	Limita inferioară de plasticitate (w) Plastic limit [%]	Indicele de plasticitate (I) Plasticity index [%]	Indicele de consistență (I) Consistency index [%]	Umiditatea (w) Water content [%]	Densitatea scheletului mineral (ρ _s) Specific density [t/m ³]	Densitatea naturală (ρ) Bulk density [t/m ³]	Densitatea stare uscată (ρ _s) Dry density [t/m ³]	Porozitatea (n) Porosity [%]	Indicele pomor (e) Void ratio	Gradul de umiditate (S) Saturation ratio [%]
RAO F10	RAOF10NT1	1,00-1,50		8,8	7,5	41,3	42,4	0,0	0,0		27,92	37,0	16,7	20,3	0,45	27,92	25,87	18,77	14,67	43,29	0,78	96,5
	RAOF10T2	4,00-4,30		6,6	4,6	14,7	36,8	37,3	0,0								26,33					
	RAOF10T3	6,35-6,70		13,2	6,8	16,3	45,2	18,5	0,0			21,5	9,7	11,8			26,24					
	RAOF10T4	9,00-9,35		13,2	5,3	16,6	45,9	19,0	0,0			25,0	11,2	13,7			26,33					
	RAOF10T5	11,50-12,00		10,2	4,9	12,5	36,5	35,9	0,0								26,44					
	RAOF10T6	14,00-14,40		7,8	6,3	17,9	46,3	21,7	0,0								26,42					
	RAOF10T7	16,00-16,35		5,9	11,2	25,1	37,6	20,2	0,0			22,1	10,4	11,7			26,40					
	RAOF10T8	19,00-19,35		3,9	8,5	19,3	42,9	25,4	0,0								26,38					
	RAOF10T9	21,00-21,30		5,9	9,7	25,6	41,0	17,8	0,0			19,5	7,9	11,5			26,48					
	RAOF10T10	24,00-24,25																				
RAOF10T11	25,50-26,00			1,7	2,4	7,1	42,9	45,9	0,0								26,52					
RAOF10T12	27,00-27,50			4,9	7,6	22,4	33,4	31,5	0,0			20,9	9,6	11,3			26,56					
RAOF10T13	32,00-32,50			7,1	6,5	30,2	45,4	7,8	0,0			21,3	10,1	11,1			26,57					
RAOF10T14	34,60-35,00			7,1	6,6	25,1	51,9	9,3	0,0								26,40					
RAOF10T15	37,00-37,40			5,6	5,9	24,1	52,7	11,7	0,0								26,38					

REHABILITATION OF THE RAILWAY LINE BRASOV – SIMERIA, COMPONENT PART OF IV PAN-EUROPEAN CORRIDOR FOR THE TRAINS CIRCULATION WITH MAXIMUM SPEED OF 160 KM/H.

RAO F12

Categorie Exemplu:		Numărul probei Number of sample	Adâncimea probei Depth of sample [m]	Argila coloidală <0,002 mm Colloidal clay [%]	Argila < 0,005 mm Clay [%]	Frați 0,075-0,05 mm Silt [%]	Nisip 0,05-2,00 mm Sand [%]	Pietriș 2-70 mm Gravel [%]	Bolovaniș 70-200 mm Cobble [%]	Grad de neuniformitate Non uniformity [U _n]	Umiditate naturală (w) Water content [%]	Limita superioară de plasticitate (I _p) Liquid limit [%]	Limita inferioară de plasticitate (I _p) Plastic limit [%]	Indicele de plasticitate (I _p) Plasticity index [%]	Indicele de consistență (I _c) Consistency index [%]	Umiditate (w) Water content [%]	Densitatea scheletului mineral (ρ _s) Specific density [t/m ³]	Densitatea naturală (ρ _n) Bulk density [t/m ³]	Densitatea tare uscată (ρ _s) Dry density [t/m ³]	Porozitatea (n) porosity [%]	Indicele porilor (e) Void ratio	Gradul de umiditate (S) Saturation ratio [%]	Modulul eozonometric (W) Ozonometric deformation modulus [t/m ²]		
RAO F12	RAOF12NT1	1,00-1,50	19,3	17,8	56,8	3,2	2,9	0,0			20,57	40,0	17,0	23,0	0,84	20,57	25,96	19,89	16,50	36,45	0,57	95,0	5702		
																							9831		
																							9831		
																							14775		
	RAOF12NT2	4,00-4,50	16,8	23,2	57,1	2,9	0,0	0,0			19,62	46,6	20,0	26,6	1,02	19,62	25,88	19,77	16,53	36,15	0,57	91,5	12182		
																								12413	
																								12413	
																								13812	
	RAOF12T3	7,00-7,35	2,2	1,9	31,8	46,1	19,0	0,0				19,0	8,6	10,4	0,00		26,30								
	RAOF12NT4	9,00-9,50	24,1	20,3	52,4	3,2	0,0	0,0			14,28	46,2	19,4	26,8	1,19	14,28	26,20	21,51	18,83	28,15	0,39	97,3			
RAOF12T5	11,00-11,50	2,2	5,8	21,0	50,3	20,7	0,0				#RIFI	#RIFI	#RIFI	#RIFI		26,39									
RAOF12T6	14,00-14,50	13,4	9,8	19,5	41,9	15,4	0,0				23,7	11,8	11,8	0,00		26,39									
RAOF12T7	17,00-17,45	12,0	9,2	19,0	45,7	14,1	0,0				23,7	9,4	14,3	0,00		26,26									
RAOF12T8	19,00-19,45	11,0	11,9	20,5	42,9	13,7	0,0				23,9	10,8	13,1	0,00		26,43									
RAOF12T10	24,00-24,45	10,2	5,7	18,2	47,6	18,3	0,0				20,9	8,1	12,8	0,00		26,40									
RAOF12T12	29,80-30,00	9,3	5,8	23,7	47,1	14,1	0,0				22,1	10,9	11,2	0,00		26,50									

REHABILITATION OF THE RAILWAY LINE BRASOV – SIMERIA, COMPONENT PART OF IV PAN-EUROPEAN CORRIDOR FOR THE TRAINS CIRCULATION WITH MAXIMUM SPEED OF 160 KM/H.

RAO F13

Proiect Ecartula	Numărul probei Number of sample	Adâncimea probei Depth of sample [m]	RAO F13																		
			Argilă coloidală <0.002 mm Colloidal clay [%]	Argilă < 0.005 mm Clay [%]	Pret 0.005-0.05 mm Silt [%]	Nisip 0.05-2.00 mm Sand [%]	Pieșis 2-70 mm Gravel [%]	Bolovaniș 70-200 mm Cobble [%]	Grad de neuniformitate Non uniformity [D _n]	Umiditatea naturală (w) Water content [%]	Limita superioară de plasticitate (w _p) Liquid limit [%]	Limita inferioară de plasticitate (w _L) Plastic limit [%]	Indicele de plasticitate (I) Plasticity index [%]	Indicele de consistență (I _c) Consistency index [%]	Umiditatea (w) Water content [%]	Densitatea scheletului mineral (ρ _s) Specific density [t/m ³]	Densitatea naturală (ρ) Bulk density [t/m ³]	Densitatea sterc uscată (ρ _d) Dry density [t/m ³]	Porozitatea (n) Porosity [%]	Indicele pomilor (e) Void ratio	Gradul de umiditate (S) Saturation ratio [%]
RAOF13NT1	1.00 - 1.50		31,2	18,1	44,3	5,1	1,3	0,0		14,79	48,6	21,3	27,3	1,24	14,79	25,85	19,41	16,91	34,59	0,53	73,7
RAOF13NT2	3.00 - 3.40		36,3	19,2	36,8	7,0	0,7	0,0		10,74	57,3	23,1	34,2	1,36	10,74	25,99	21,24	19,18	26,18	0,35	80,2
RAOF13T3	9.00 - 9.40		12,0	8,0	19,7	42,5	19,8	0,0			21,9	10,4	11,5			25,84					
RAOF13T4	11.00 - 11.45		13,9	8,3	24,9	43,9	9,0	0,0			22,1	10,9	11,2			25,81					
RAOF13T5	14.00 - 14.40		22,7	9,3	17,0	34,7	16,3	0,0			37,4	17,8	19,7			25,82					
RAOF13T6	16.00 - 16.35																				
RAOF13T7	19.00 - 19.45		13,8	9,1	27,1	47,9	2,1	0,0			24,9	11,4	13,5			25,85					
RAOF13T8	21.00 - 21.35		12,2	10,8	29,4	26,0	21,6	0,0			27,1	13,2	13,9			26,05					
RAOF13T9	23.60 - 24.00		12,3	7,2	19,2	43,9	17,4	0,0			24,2	11,3	12,8			25,87					
RAOF13T10	26.00 - 26.45		26,0	17,1	51,0	5,5	0,4	0,0			46,6	22,2	24,4			26,11					

REHABILITATION OF THE RAILWAY LINE BRASOV – SIMERIA, COMPONENT PART OF IV PAN-EUROPEAN CORRIDOR FOR THE TRAINS CIRCULATION WITH MAXIMUM SPEED OF 160 KM/H.

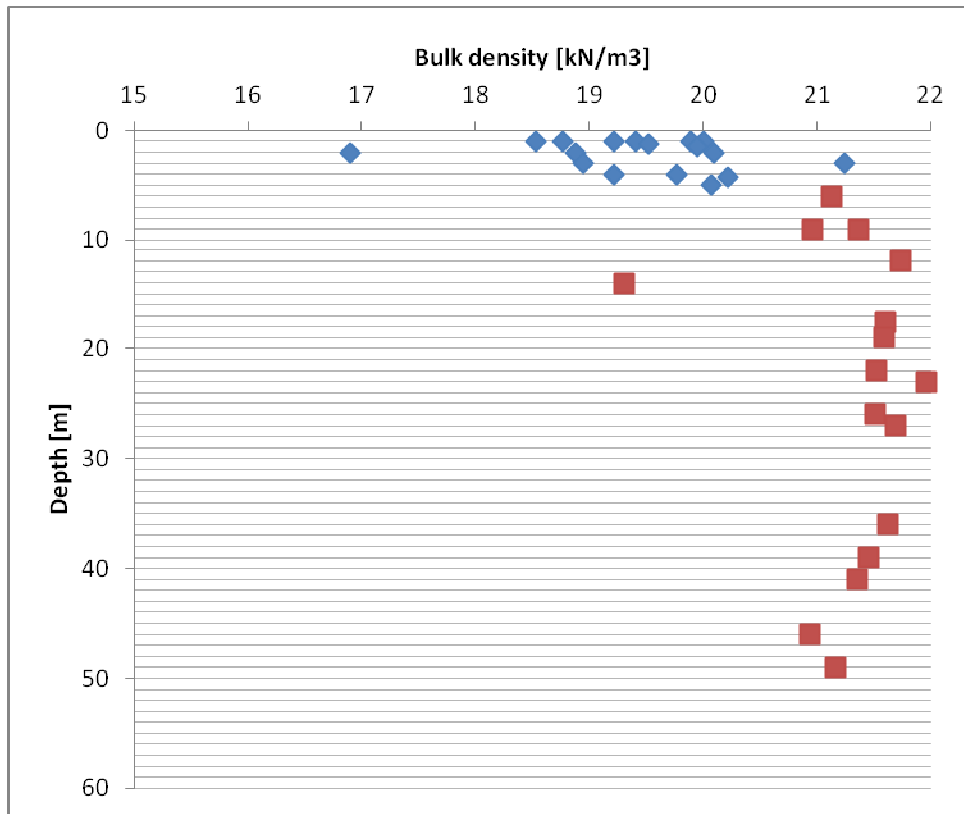

REHABILITATION OF THE RAILWAY LINE BRASOV – SIMERIA, COMPONENT PART OF IV PAN-EUROPEAN CORRIDOR FOR THE TRAINS CIRCULATION WITH MAXIMUM SPEED OF 160 KM/H.

3.4.2. Parametrii de rezistență și de deformare

RAO F1

Projeții Partiale	Numărul probei Number of sample	Adâncimea probei Depth of sample [m]	Modulul edometric (M) Oedometric deformation modulus [kPa]	Deformația specifică (ε) Strain [%]	Coeficient de compresibilitate (av) Compressibility coefficient [1/kPa]	Tăsarea specifică suplimentară prin umiditate (w _{sp}) Addit. Spec. settl. by wetting [%]	Tăsarea de încercare Loading step [kPa]	Indice de compresune (Cc) Compression index (Cc)	Indice de recompresune (Cr) Swell index (Cs)	Presiune de umflare Swelling pressure [kPa]	Coeficient de consolidare Consolidation coefficient C _α [cm ² /sec]	Presiune de preconsolidare Ep [kPa] Pre-consolidation pressure	σ _v /σ ₁ [kPa]			Unghiul de frecare internă total (φ) Total angle of internal friction [°]	Coeziunea totală (c) Total cohesion [kPa]	Unghi efectiv de frecare internă (φ') Effective angle of internal friction [°]	Coeziunea efectivă (c') Effective cohesion [kPa]	Rezistența monoaxială Compressive strength [kPa]	Deformare relativă (deformation) [%]	Umflarea liberă (%) Swelling (%)	Conținutul de materie organică (%)	SO ₂ (%)	CaCO ₃ (%)			
													1	2	φ													
RAO F1	RAOF1PNT1	4,30-4,80	13890	1,19	0,00011		196,13	0,035					24,5	49,0	98,1	24,6	44,8											
			16143	1,80	0,00009		294,20	0,055						56,0	67,2	89,6												
			16143	2,41	0,00009		392,27	0,074																				
			22873	4,12	0,00007		784,53	0,098																				
	RAOF1PT2	7,10-7,50																										
	RAOF1PT3	12,04-12,40																										
RAOF1PT4	18,00-18,50																											
RAOF1PT5	24,60-25,00																											
RAOF1PT6	29,60-29,90																											

REHABILITATION OF THE RAILWAY LINE BRASOV – SIMERIA, COMPONENT PART OF IV PAN-EUROPEAN CORRIDOR FOR THE TRAINS CIRCULATION WITH MAXIMUM SPEED OF 160 KM/H.

RAO F2

Faza Baută	Numărul probei Number of sample	Adâncimea probei Depth of sample [m]	Modulul edometric (M) Oedometric deformation modulus [kPa]	Deformația specifică (ε) Strain [%]	Coeficient de compresibilitate (αv) Compressibility coefficient [1/MPa]	Măsură specifică suplimentară prin umedire (w _{sp}) Aditt. Specifici by wetting [%]	Treapta de încărcare Loading step [kPa]	Indice de compresie (Cc) Compression index (Cc)	Indice de recompresie (Cr) Swell index (Cr)	Presiune de umflare Swelling pressure [kPa]	Coeficient de consolidare Consolidation coefficient (C _α , C _{α1} , C _{α2})	Presiune de preconsolidare (Pp) [kPa] Pre-consolidation pressure	σ _s /σ _i [kPa]			Unghiul de frecare internă totală (φ) Total angle of internal friction [°]	Coesiunea totală (c) Total cohesion [kPa]	Unghi efectiv de frecare internă (φ') Effective angle of internal friction [°]	Coesiunea efectivă (c') Effective cohesion [kPa]	Rezistența monoaxială Compressive strength [kPa]	Deformare relativă (deformation) [%]	Umflare liberă (%) Swelling (%)	Continutul de materie organică (%)	SO ₄ (%)	CaCO ₃ (%)					
													1	2	3															
RAO F2	RAOF2PNT1	2,00-2,40	2476	14,49	0,00091		196,13	0,296					24,5	49,0	98,1	24,7	28,6													
			4732	16,56	0,00047		294,20	0,334					40,0	51,0	73,7		F CU													
			4732	18,63	0,00047		392,27	0,373																						
			8895	23,04	0,00025		784,53	0,329																						
	RAOF2PT2	33,10-3,40																												
	RAOF2PT3	6,60-6,90																												7,39
	RAOF2PT4	14,50-14,98																												8,27
RAOF2PT5	19,70-20,00																												7,25	
RAOF2PT6	25,70-26,00																												5,68	
RAOF2PT7	29,70-30,00																												6,98	

REHABILITATION OF THE RAILWAY LINE BRASOV – SIMERIA, COMPONENT PART OF IV PAN-EUROPEAN CORRIDOR FOR THE TRAINS CIRCULATION WITH MAXIMUM SPEED OF 160 KM/H.

RAO F3

Faregiul / Forthole	Numărul probei / Number of sample	Adâncimea probei / Depth of sample [m]	Modulul edometric (M) / Oedometric deformation modulus [kPa]	Deformația specifică (ε) / Strain [%]	Coeficient de compresibilitate (av) / Compressibility coefficient [1/kPa]	Tasarea specifică suplimentară prin umedare (w _{ad}) / Spec. settl. by wetting [%]	Trecuța de încărcare / Loading step [kPa]	Indice de compresie (Cc) / Compression index (Cc)	Indice de recompresie (Cr) / Swell index (Cs)	Presiune de umflare / Swelling pressure [kPa]	Coeficient de consolidare / Consolidation coefficient [c _v] [cm ² /sec]	Presiune de preconsolidare P _p [kPa] / Pre-consolidation pressure			Unghiul de frecare internă totală (φ) / Total angle of internal friction [°]	Coeziunea totală (c) / Total cohesion [kPa]	Unghi efectiv de frecare internă (φ') / Effective angle of internal friction [°]	Coeziunea efectivă (c') / Effective cohesion [kPa]	Rezistența monoaxială / Compressive strength [kPa]	Deformare relativă (deformație) [%]	Umflarea liberă (%) / Swelling (%)	Conținutul de materie organică (%)	SO ₄ (%)	CaCO ₃ (%)			
												1	2	3													
RAO F3	RAOF3PNT1	1,20-1,70	9807	0,68	0,00028		98,07	0,040			1,99E-03		24,5	49,0	98,1	24,9	28,5										
			13076	1,43	0,00020		196,13	0,069				1,99E-03		38,0	49,0	72,1											
			18445	3,03	0,00013		490,33	0,098				5,50E-04															
	RAOF3PT2	6,60-7,00																							10,45		
	RAOF3PT3	11,00-11,40																								8,08	
	RAOF3PT4	17,60-18,00																									9,30
RAOF3PT5	22,60-23,00																										12,23
RAOF3PT6	28,60-29,00																										

RAO F5

Faregiul / Forthole	Numărul probei / Number of sample	Adâncimea probei / Depth of sample [m]	Modulul edometric (M) / Oedometric deformation modulus [kPa]	Deformația specifică (ε) / Strain [%]	Coeficient de compresibilitate (av) / Compressibility coefficient [1/kPa]	Tasarea specifică suplimentară prin umedare (w _{ad}) / Spec. settl. by wetting [%]	Trecuța de încărcare / Loading step [kPa]	Indice de compresie (Cc) / Compression index (Cc)	Indice de recompresie (Cr) / Swell index (Cs)	Presiune de umflare / Swelling pressure [kPa]	Coeficient de consolidare / Consolidation coefficient [c _v] [cm ² /sec]	Presiune de preconsolidare P _p [kPa] / Pre-consolidation pressure			Unghiul de frecare internă totală (φ) / Total angle of internal friction [°]	Coeziunea totală (c) / Total cohesion [kPa]	Unghi efectiv de frecare internă (φ') / Effective angle of internal friction [°]	Coeziunea efectivă (c') / Effective cohesion [kPa]	Rezistența monoaxială / Compressive strength [kPa]	Deformare relativă (deformație) [%]	Umflarea liberă (%) / Swelling (%)	Conținutul de materie organică (%)	SO ₄ (%)	CaCO ₃ (%)					
												1	2	3															
RAO F5	RAOF5NT1	2,00-2,50	3280	2,29	0,00108		98,07	0,110			1,93E-03		24,5	49,0	98,1	24,5	29,9										1,5		
			4991	4,26	0,00043		196,13	0,098				5,32E-04		41,3	52,0	74,7													
			10757	5,17	0,00017		294,20	0,116				5,32E-04																	
	10757	6,99	0,00015		490,33	0,000					2,35E-04																		
	RAOF5T2	5,50-5,80																										1,4	
	RAOF5T3	11,00-11,50																											1,8
RAOF5NT4	17,50-18,00																												
RAOF5NT5	23,00-23,50																												
RAOF5NT6	26,00-26,50																												

REHABILITATION OF THE RAILWAY LINE BRASOV – SIMERIA, COMPONENT PART OF IV PAN-EUROPEAN CORRIDOR FOR THE TRAINS CIRCULATION WITH MAXIMUM SPEED OF 160 KM/H.

RAO F6

Categorie Echivalent	Numărul probei Number of sample	Adâncimea probei Depth of sample [m]	Modulul edometric (M) - Oedometric deformation modulus [kPa]	Deformația specifică (ε) Strain [%]	Coeficient de compresiune (av) Compressibility coefficient [1/MPa]	Tasarea specifică suplimentară prim lumezire (I _{sp}) - Adit. Spec. settl. by wetting [%]	Treapta de încercare Loading step [kPa]	Indice de compresiune (Cc) Compression index (Cc)	Indice de recomprimune (Cr) Swell index (Cs)	Presiune de umflare Swelling pressure [kPa]	Coeficient de consolidare Consolidation coefficient (C _v) [m ² /sec]	Presiune de preconsolidare P _p [kPa] Pre-consolidation pressure			Unghiul de frecare internă totală (φ) Total angle of internal friction [°]	Coeziunea totală (c) Total cohesion [kPa]	Unghi efectiv de frecare internă (φ') Effective angle of internal friction [°]	Coeziunea efectivă (c') Effective cohesion [kPa]	Rezistența monoaxială Compressive strength [kPa]	Deformare elastică (deformation) [%]	Umflarea liberă (%) Swelling (%)	Conținutul de materie organică (%)	SO ₄ (%)	CaCO ₃ (%)				
												σ _v /σ ₁	n ₁	ω														
RAO F6	RAOF6T1	2,00-2,50	11537	0,91	0,00013		98,07	0,031			8,25E-03		24,5	49,0	98,1	23,8	38,5								1,3			
			16209	1,51	0,00009		196,13	0,098				2,13E-03		49,5	60,0	81,9												
			29868	1,84	0,00007		294,20	0,038				2,13E-03																
			29868	2,50	0,00008		490,33	0,000				1,54E-04																
	RAOF6T2	8,00-8,50																							1,4			
	RAOF6T3	12,00-12,50																										
	RAOF6T4	18,00-18,50																										
	RAOF6T5	24,50-25,00																									8,32	
	RAOF6T6	29,50-30,00																									7,72	

REHABILITATION OF THE RAILWAY LINE BRASOV – SIMERIA, COMPONENT PART OF IV PAN-EUROPEAN CORRIDOR FOR THE TRAINS CIRCULATION WITH MAXIMUM SPEED OF 160 KM/H.

RAO F7

Profil Profile	Numărul probei Number of sample	Adâncimea probei Depth of sample [m]	Modulul elometric (M) Oedometric deformation modulus [kPa]	Deformație specifică ϵ Strain [%]	Coefficient de compresibilitate (av) Compressibility coefficient [1/kPa]	Tășarea specifică suplimentară prin umiditate (w_p) Aditt. Spec. settl. by swelling [%]	Treapta de încărcare Loading step [kPa]	Indice de compresivitate (Cc) Compression index (Cc)	Indice de recompresivitate (Cr) Swell index (CS)	Presiune de umflare Swelling pressure [kPa]	Coefficient de consolidare Consolidation coefficient	[c_u] [cm ² /sec]	Presiune de preconsolidare P_p [kPa] Pre-consolidation pressure	σ_3/σ_1 [kPa]			Unghiul de frecare internă totală Φ Total angle of internal friction Φ	Coezinea totală (c) Total cohesion [kPa]	Unghi efectiv de frecare internă Φ_e Effective angle of internal friction Φ_e	Coezinea efectivă (c') Effective cohesion [kPa]	Rezistența monoaxială Compressive strength [kPa]	Deformare relativă (deformation) [%]	Umflarea liberă (%) Swelling (%)	Conținutul de materie organică (%) SO ₄ (%)	CaCO ₃ (%)			
			1	2	3																							
			Coeficient de recompresivitate (Cr) Swell index (CS)																									
RAO F7	RAOF7NT1	1.00 - 1.50	4458	8,06	0,00040		196,13	0,130			24,5	49,0	96,1	15,7	21,9													
			6906	7,48	0,00026		294,20	0,166				28,6	36,0	49,4	F CU													
			6906	8,90	0,00026		392,27	0,202																				
			11240	12,39	0,00018		784,53	0,206																				
	RAOF7NT2	4.00 - 4.50	8915	4,23	0,00020		196,13	0,064			24,5	49,0	96,1	29,6	23,0													
			16551	4,82	0,00011		294,20	0,073				37,2	50,4	78,9	F CU													
			16551	5,41	0,00011		392,27	0,082																				
	RAOF7NT3	6.00 - 6.50	30432	6,70	0,00006		784,53	0,074			50	150	300	23,0	68,5	30,6	40,2									0,00		
											263	402	593	Trx CU														
	RAOF7NT4	9.00 - 9.50									100	200	350	23,0	86,3	34,2	37,6									9,07		
											392	521	689	Trx CU														
RAOF7T5	11.50 - 12.00																								12,14			
RAOF7T6	14.00 - 14.50																								12,91			
RAOF7T9	21.00 - 21.50																								13,64			
RAOF7T10	24.00 - 24.50																								17,47			
RAOF7T11	28.00 - 28.45																								17,35			

REHABILITATION OF THE RAILWAY LINE BRASOV – SIMERIA, COMPONENT PART OF IV PAN-EUROPEAN CORRIDOR FOR THE TRAINS CIRCULATION WITH MAXIMUM SPEED OF 160 KM/H.

RAO F8bis

Profilul Ecartula	Numărul probei Number of sample	Adâncimea probei Depth of sample [m]	Modulul eodometric (M) Oedometric deformation modulus [kPa]	Deformația specifică (ε) Strain [%]	Coeficient de compresibilitate (αv) Compressibility coefficient [1/kPa]	Tasarea specifică suplimentară prin umectare (I _{sw}) Addit. Spec. settl. by wetting [%]	Trepăla de încercare Loading step [kPa]	Indice de compresură (C _c) Compression index (C _c)	Indice de recompresură (C _r) Swell index (C _r)	Presiune de umflare Swelling pressure [kPa]	Coeficient de consolidare Consolidation coefficient C _s [cm ² /sec]	Presiune de preconsolidare P _p [kPa] Pre-consolidation pressure			Unghiul de frecare internă totală (φ) Total angle of internal friction [°]			Coesiunea totală (c) Total cohesion [kPa]	Unghi efectiv de frecare internă (φ') Effective angle of internal friction [°]	Coesiunea efectivă (c') Effective cohesion [kPa]	Rezistența monoaxială Compressive strength [kPa]	Deformare relativă (deformation) [%]	Umflare liberă (%) Swelling (%)	Continutul de materie organică (%)	SO ₄ (%)	CaCO ₃ (%)									
												1	2	φ	1	2	φ																		
RAO F8 BIS	RAOF8BIS NT1	1.00 - 1.50	9521	0,72	0,00022		98,07	0,034			2,82E-03	24,5	49,0	98,1	23,4	40,3																			
			15691	1,34	0,00009		196,13	0,098			1,50E-03	51,0	61,5	82,8		F CU																			
			36321	1,61	0,00007		294,20	0,033			1,50E-03																								
			36321	2,15	0,00012		490,33	0,000			1,28E-04																								
	RAOF8BIS T2	3.00 - 3.40																																	
	RAOF8BIS T3	6.00 - 6.40																																	
	RAOF8BIS T4	8.45 - 8.70																																	
	RAOF8BIS T5	11.00 - 11.40																																	
	RAOF8BIS T6	14.00 - 14.40																																	
	RAOF8BIS T7	16.00 - 16.45																																	
RAOF8BIS T8	19.45 - 19.90																																		
RAOF8BIS T9	21.65 - 22.00																																	5,19	
RAOF8BIS T10	24.00 - 24.45																																	6,21	

REHABILITATION OF THE RAILWAY LINE BRASOV – SIMERIA, COMPONENT PART OF IV PAN-EUROPEAN CORRIDOR FOR THE TRAINS CIRCULATION WITH MAXIMUM SPEED OF 160 KM/H.

RAO F8bis

Profilul Borhoale		Modulul edometric (M) / Oedometric de formation modulus [kPa]	Deformata specifică (ε) Strain [%]	Coefficient de compresiibilitate (av) Compressibility coefficient [1/kPa]	Tasarea specifica suplimentare prin umiditate (w _{sp}) Spec. settl. bywelling [%]	Treapta de incercare Loading step [kPa]	Indice de compresune (Co) Compression index (Co)	Indice de recompresune (Cr) Swell index (Cr)	Presiune de umflare Swelling pressure [kPa]	Coefficient de consolidare Consolidation coefficient K _s [cm ² /sec]	Presiune de preconsolidare P _p [kPa] Pre-consolidation pressure	σ ₁ /σ ₃ [kPa]	Unghiul de frecare internă totală (φ) Total angle of internal friction [°]	Coeziunea totală (c) Total cohesion [kPa]	Unghi efectiv de frecare internă (φ') Effective angle of internal friction [°]	Coeziunea efectivă (c') Effective cohesion [kPa]	Rezistența monoaxială Compressive strength [kPa]	Deformare relativă (deformatur) [%]	Umflare liberă (%) Swelling (%)	Continutul de materie organică (%)	SO ₂ (%)	CaCO ₃ (%)		
RAO F8 BIS	RAOF8BIS T11	26.00 - 27.00																					7.87	
	RAOF8BIS T12	31.00 - 31.40																					9.99	
	RAOF8BIS T13	34.40 - 34.85																					10.00	
	RAOF8BIS NT14	36.00 - 36.50									150 363	300 584	450 774	23,1	67,2	26,7	33,5						7.07	
	RAOF8BIS NT15	39.00 - 39.50									150 408	350 683	500 874	23,6	70,8	29,3	39,2						6.76	
	RAOF8BIS NT16	41.00 - 41.50																						
	RAOF8BIS NT17	44.00 - 44.50																						
	RAOF8BIS NT18	46.00 - 46.50										300 599	450 803	600 1011	24,1	60,3	30,2	29,3						6.92
	RAOF8BIS NT19	49.00 - 49.50										300 599	450 797	600 999	23,0	76,3	28,5	42,6						7.54

REHABILITATION OF THE RAILWAY LINE BRASOV – SIMERIA, COMPONENT PART OF IV PAN-EUROPEAN CORRIDOR FOR THE TRAINS CIRCULATION WITH MAXIMUM SPEED OF 160 KM/H.

RAO F10

Profil Profile	Numărul probei Number of sample	Adâncimea probei Depth of sample [m]	Modulul ecometric (M) Oedometric deformation modulus [kPa]	Deformația specifică (ε) Strain [%]	Coeficient de compresibilitate (αv) Compressibility coefficient [1/kPa]	Tasarea specifică suplimentară prin umezire (w _{sp}) Addit. Spec. settl. by wetting [%]	Treapta de încercare Loading step [kPa]	Indice de compresie (Cc) Compression index (Cc)	Indice de recompresie (Cr) Swelling index (Cs)	Presiune de umflare Swelling pressure [kPa]	Coeficient de consolidare Consolidation coefficient [kPa ⁻¹ sec]	Presiune de preconsolidare Ep [kPa] Pre-consolidation pressure	σ ₃ /σ ₁ [kPa]			Unghiul de frecare internă (total) Total angle of internal friction [°]	Coeziunea totală (c) Total cohesion [kPa]	Unghi efectiv de frecare internă (φ') Effective angle of internal friction [°]	Coeziunea efectivă (c') Effective cohesion [kPa]	Rezistența monoaxială Compressive strength [kPa]	Deformare relativă (deformation) [%]	Umflarea liberă (%) Swelling (%)	Conținutul de materie organică (%)	SO ₄ (%)	CaCO ₃ (%)			
													1	2	φ													
RAO F10	RAOF10NT1	1,00-1,50	4245	8,41	0,00042		196,13	0,135					24,5	49,0	98,1	22,9												
			7861	9,66	0,00022		294,20	0,156						20,5	29,2	51,3												
			7861	10,91	0,00022		392,27	0,176																				
			14422	13,63	0,00012		784,53	0,159																				
	RAOF10T2	4,00-4,30																										
	RAOF10T3	6,35-6,70																										
	RAOF10T4	9,00-9,35																										
	RAOF10T5	11,50-12,00																									0,00	
	RAOF10T6	14,00-14,40																										
	RAOF10T7	16,00-16,35																										
RAOF10T8	19,00-19,35																											
RAOF10T9	21,00-21,30																									3,91		
RAOF10T10	24,00-24,25																											

REHABILITATION OF THE RAILWAY LINE BRASOV – SIMERIA, COMPONENT PART OF IV PAN-EUROPEAN CORRIDOR FOR THE TRAINS CIRCULATION WITH MAXIMUM SPEED OF 160 KM/H.

RAO F10

Terminul Bazaia		Modulul edometric (M) - Oedometric deformation modulus [kPa]	Deformația specifică (%) Strain [%]	Coefficient de compresibilitate (av) Compressibility coefficient [1/MPa]	Tăstarea specifică suplimentară prin umectare (I _{wp}) Adit. Aclit. Succ. satll. by wetting [%]	Treapta de încercare Loading step [kPa]	Indice de compresune (Cc) Compression index (Cc)	Indice de recompresune (Cr) Swell index (Cs)	Presiune de umflare Swelling pressure [kPa]	Coefficient de consolidare Consolidation coefficient (C _α) [cm ² /sec]	Presiune de preconsolidare Pp [kPa] Pre-consolidation pressure	σ _v /σ ₁ [kPa]	Unghiul de încercare internă totală (ϕ) Total angle of internal friction [°]	Coeziunea totală (c) Total cohesion [kPa]	Unghi efectiv de frecare internă (ϕ') Effective angle of internal friction [°]	Coeziunea efectivă (c') Effective cohesion [kPa]	Rezistența monoaxială Compressive strength [kPa]	Deformare elastică (deformation) [%]	Umflarea liberă (%) Swelling (%)	Conținutul de materie organică (%)	SO ₄ (%)	CaCO ₃ (%)	
RAO F10	RAOF10T11	25,50 -26,00																					
	RAOF10T12	27,00 -27,50																					0,00
	RAOF10T13	32,00 -32,50																					4,49
	RAOF10T14	34,80 -35,00																					
	RAOF10T15	37,00 -37,40																					4,05
	RAOF10T16	4,00 -40,30																					3,83

REHABILITATION OF THE RAILWAY LINE BRASOV – SIMERIA, COMPONENT PART OF IV PAN-EUROPEAN CORRIDOR FOR THE TRAINS CIRCULATION WITH MAXIMUM SPEED OF 160 KM/H.

RAO F11

Forajul Borehole	Numărul probei Number of sample	Adâncimea probei Depth of sample [m]	Modulul edometric (M) Oedometric deformation modulus [kPa]	Deformația specifică ϵ Strain [%]	Coeficient de compresibilitate (av) Compressibility coefficient [1/kPa]	Tăreala specifică suplimentară prim umiditate (w_p) Spec. sett. by wetting [%]	Aditt. Tăreala de încercare Loading step [kPa]	Indice de compresune (Cc) Compression index (Cc)	Indice de recompresune (Cr) Swell index (Cs)	Presiune de umflare Swelling pressure [kPa]	Coeficient de consolidare Consolidation coefficient (c_s) [cm ² /sec]	Presiune de preconsolidare Pp [kPa] Pre-consolidation pressure	σ_3/σ_1 [kPa]			Unghiul de frecare internă totală(ϕ) Total angle of internal friction [°]	Coesiunea totală (c) Total cohesion [kPa]	Unghi efectiv de frecare internă($\phi')$ Effective angle of internal friction [°]	Coesiunea efectivă (c') Effective cohesion [kPa]	Rezistența monoaxială Compressive strength [kPa]	Deformație relativă (deformation) [%]	Umflare liberă (%) Swelling (%)	Conținutul de materie organică (%)	SO ₄ (%)	CaCO ₃ (%)				
													1	2	ϕ														
RAO F11	RAOF11NT1	1.00-1.50	7132	2,71	0,00022		196,13	0,071					24,5	49,0	98,1	22,4	24,7												
			9638	3,73	0,00016		294,20	0,099						34,9	44,5	85,1													
			9638	4,74	0,00016		392,27	0,126																					
			14264	7,49	0,00011		784,53	0,142																					
	RAOF11NT2	3.00-3.50	4245	4,81	0,00041		196,13	0,134					24,5	49,0	98,1	23,6	25,2												
			7360	6,15	0,00024		294,20	0,160					36,8	45,2	68,4														
			7360	7,48	0,00024		392,27	0,186																					
			11127	10,82	0,00015		784,53	0,194																					
	RAOF11T3	5.50-6.00																									9,13		
	RAOF11NT4	9.00-9.50											150	300	450	23,3	58,6	29,0	30,2								6,13		
													367	565	758	Trx CU													
	RAOF11NT5	12.00-12.50											150	300	450	23,2	79,0	29,9	45,2								0,00		
												427	626	822	Trx CU														
RAOF11NT6	14.50-15.00																										0,00		
RAOF11NT7	16.00-16.50												150	200	350	24,6	65,9	31,4	40,1								0,00		
												412	481	718	Trx CU														
RAOF11NT8	19.00-19.50												100	200	400	22,4	77,8	31,4	50,2								0,00		
												362	457	739	Trx CU														
RAOF11NT9	22.00-22.35												100	200	400	24,2	70,1	31,0	52,0								0,00		
												359	492	784	Trx CU														
RAOF11NT10	24.50-25.00												100	200	400	23,5	80,1	29,8	55,2								0,00		
												361	485	759	Trx CU														
RAOF11NT11	27.00-27.50												100	200	400	22,4	64,0	27,8	42,1										
												313	434	686	Trx CU														
RAOF11T12	30.00-30.35																										0,00		

REHABILITATION OF THE RAILWAY LINE BRASOV – SIMERIA, COMPONENT PART OF IV PAN-EUROPEAN CORRIDOR FOR THE TRAINS CIRCULATION WITH MAXIMUM SPEED OF 160 KM/H.

RAO F12

Pozitie Probe Number of probe Depth of sample [m]		Modulul elonometric (M) / Oedometric deformation modulus [kPa]	Deformatia specifica (ε) / Strain [%]	Coeleient de compresibilitate (av) / Compressibility coefficient [1/kPa]	masa specifica suplimentara prin umectare (µ _h) / Addit. water specific supplem. pr. moisture [%]	Treapta de incarcare / Loading step [kPa]	Indice de compresure (Cc) / Compression index [Cc]	Indice de recompresure (Cr) / Swell index [Cs]	Presiune de umitare / Swelling pressure [kPa]	Coeleient de consolidare / Consolidation coefficient [c _v] [cm ² /sec]	Presiune de recompresure / Pre-consolidation pressure [kPa]	σ ₁ /σ ₃ [kPa]			Unghiul de frecare internă total (ϕ) / Total angle of internal friction [°]		Coesiunea totală (c) / Total cohesion [kPa]		Unghi efectiv de frecare internă (ϕ') / Effective angle of internal friction [°]		Cheziunea efectivă (c') / Effective cohesion [kPa]	Rezistența monoaxială / Compressive strength [kPa]	Deformare relativă (deformation) [%]	Umflarea liberă (Sw) / Swelling [%]	Cantitatea de materie organică (%)							
																					1	2	3									
RAO F12	RAOF12NT1	1,00-1,50	5702	4,35	0,00028	198,13	0,090					24,5	49,0	98,1	22,4	30,8	F CU															
			9821	5,35	0,00016	294,20	0,108						42,2	46,0	71,9																	
			9831	6,35	0,00016	392,27	0,126																									
			14775	9,00	0,00011	784,53	0,139																									
	RAOF12NT2	4,00-4,50	12182	1,88	0,00013	196,13	0,042						24,5	49,0	98,1	18,2	31,8	F CU														
			12413	2,67	0,00013	294,20	0,070							41,1	46,0	64,7																
			12413	3,46	0,00013	392,27	0,099																									
			13812	6,30	0,00011	784,53	0,148																									
																															4,50	
														50	100	250	21,8	33,2	38,5	22,3											0,08	
														153	220	391	Trix CU															
	RAOF12T5	11,00-11,50																														
	RAOF12T6	14,00-14,50																												5,00		
	RAOF12T7	17,00-17,45																												4,97		
	RAOF12T8	19,00-19,45																												12,21		
	RAOF12T10	24,00-24,45																												3,43		
	RAOF12T12	29,80-30,00																												4,32		

REHABILITATION OF THE RAILWAY LINE BRASOV – SIMERIA, COMPONENT PART OF IV PAN-EUROPEAN CORRIDOR FOR THE TRAINS CIRCULATION WITH MAXIMUM SPEED OF 160 KM/H.

RAO F13

F. nr. probă Bottle	Numărul probei Number of sample	Adâncimea probei Depth of sample [m]	Modulul edometric (M) Oedometric deformation modulus [kPa]	Deformația specifică (g) Strain [%]	Coeficient de compresiune (av) Compressibility coefficient [1/kPa]	Trecerea specifică suplimentară prin unezi (‰) Adit. Spec. settl by wetting [‰]	Treapta de încercare Loading step [kPa]	Indice de compresiune (Cc) Compression index (Cc)	Indice de recomprimare (Cr) Swell index (Cs)	Presiune de umflare Swelling pressure [kPa]	Coeficient de consolidare Consolidation coefficient (c _v) [cm ² /sec]	Presiune de preconsolidare P _n [kPa] Pre-consolidation pressure	c _s /c _i [kPa]			Unghiul de frecare internă totală (φ) Total angle of internal friction [°]	Coesurența totală (c) Total cohesion [kPa]	Unghi efectiv de frecare internă (φ') Effective angle of internal friction [°]	Coezivitatea efectivă (c') Effective cohesion [kPa]	Rezistența monoaxială Compressive strength [kPa]	Deformare relativă (deformation) [%]	Umflarea liberă (%) Swelling [%]	Conținutul de materie organică (%)	SO ₄ (%)	CaCO ₃ (%)											
													1	2	∞																					
RAO F13	RAOF13NT1	1.00 - 1.50	11916	0,97			98,07	0,021	0,060		1,61E-03	144,2	24,5	49,0	98,1	26,5	36,5																			
			14316	1,86			196,13	0,035	0,000		4,84E-04		44,6	53,0	69,2		F CU																			
			18702	2,25			294,20	0,084	0,000		4,84E-04																									
			18702	3,42			490,33	0,088	0,000		2,10E-04																									
	RAOF13NT2	3.00 - 3.40	8896	1,91			98,07	0,032	0,060		2,48E-04	144,2	24,5	49,0	98,1	26,5	20,7										3,1									
			10289	2,86			196,13	0,043	0,000		3,44E-04		30,0	39,8	58,5		F CU																			
			20250	3,35			294,20	0,084	0,000		3,44E-04																									
			20250	4,31			490,33	0,049	0,000		6,34E-04																									
	RAOF13T3	9.00 - 9.40																																		
	RAOF13T4	11.00 - 11.45																																		1,09
RAOF13T5	14.00 - 14.40																																	2,84		
RAOF13T6	18.00 - 18.35																																			
RAOF13T7	19.00 - 19.45																																		3,15	
RAOF13T8	21.00 - 21.35																																		3,37	
RAOF13T9	23.60 - 24.00																																		3,87	
RAOF13T10	26.00 - 26.45																																		4,29	

REHABILITATION OF THE RAILWAY LINE BRASOV – SIMERIA, COMPONENT PART OF IV PAN-EUROPEAN CORRIDOR FOR THE TRAINS CIRCULATION WITH MAXIMUM SPEED OF 160 KM/H.

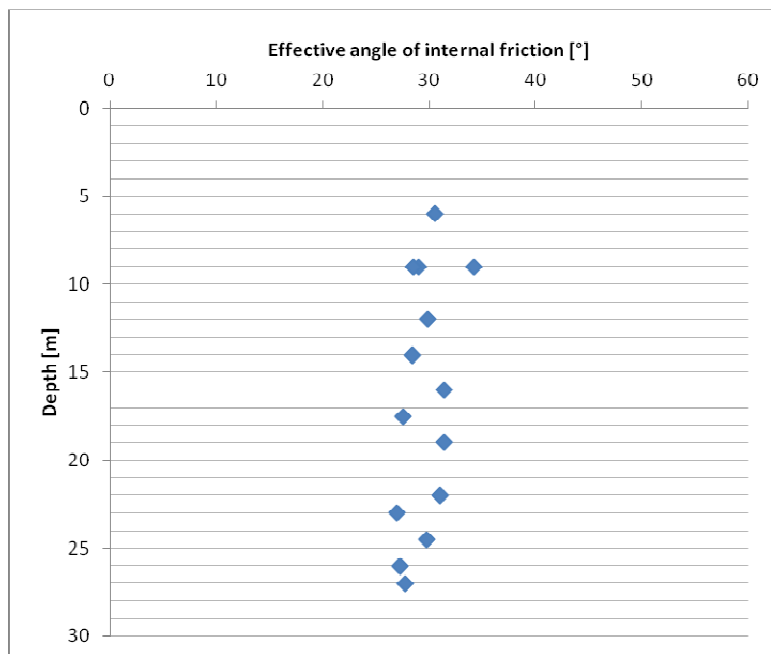
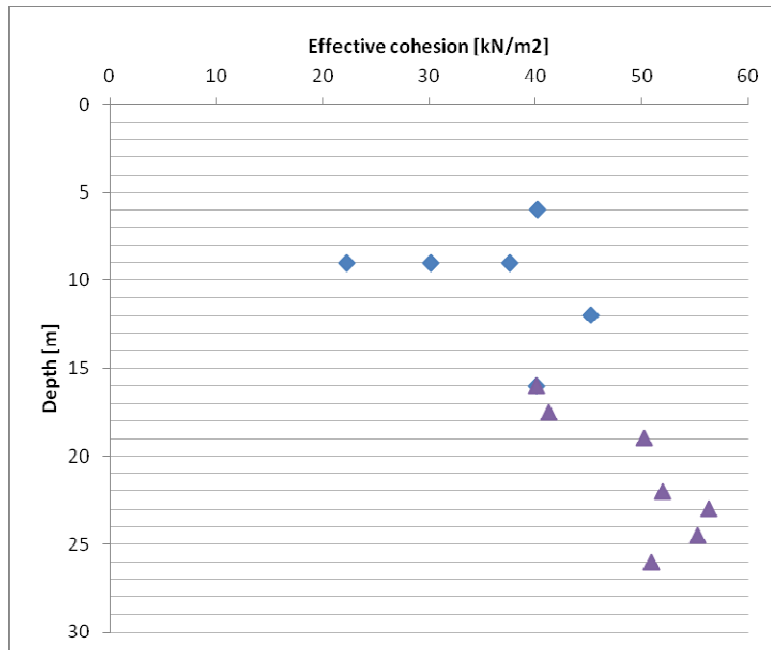

REHABILITATION OF THE RAILWAY LINE BRASOV – SIMERIA, COMPONENT PART OF IV PAN-EUROPEAN CORRIDOR FOR THE TRAINS CIRCULATION WITH MAXIMUM SPEED OF 160 KM/H.

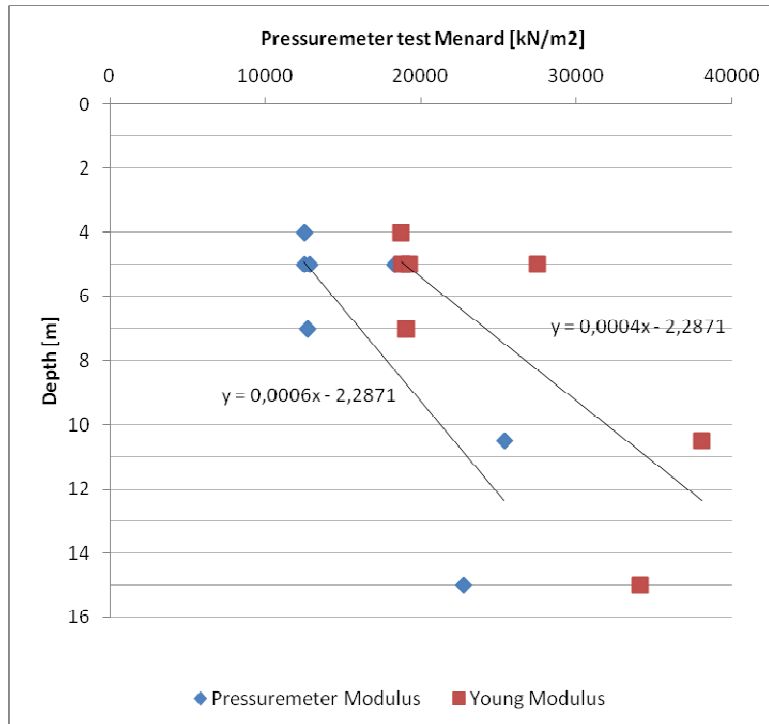
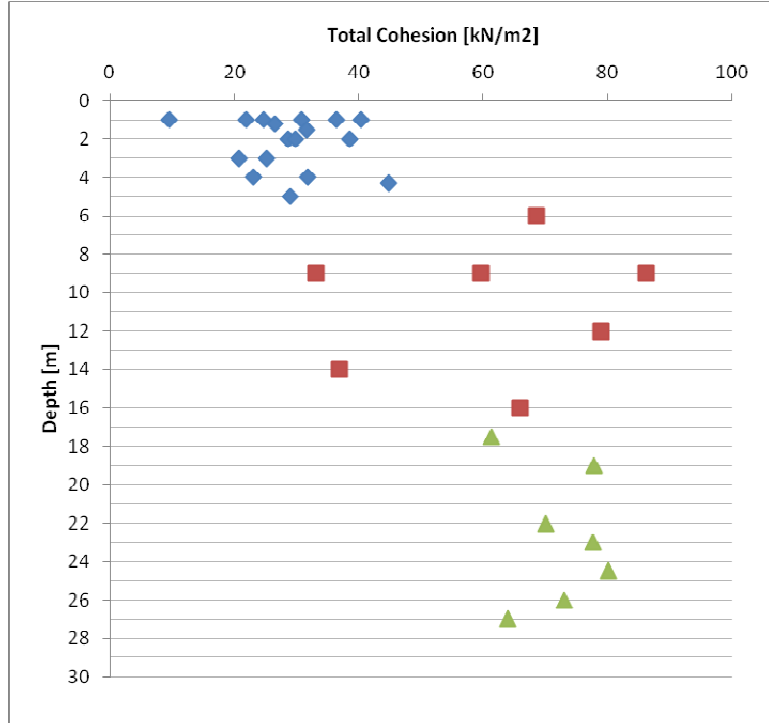

3.5 Parametrii geotehnici

În această secțiune sunt descriși parametrii geotehnici ai proiectului cu referiri la investigația din teren.

Materialele au fost modelate cu un model “continuu echivalent” de comportare, descris de o plastică lineară perfect-elastică cu criteriul de rupere Mohr-Coulomb și cu legea de curgere neasociată. În tabelele următoare sunt sintetizați parametrii de proiectare folosiți în următoarele analize. Se face distincție între parametrii “M1” și “M2” conform Eurocod 7. Parametrii caracteristici “M1” sunt sintetizați mai jos:

z1 (m from g.l.)	z2 (m from g.l.)	γ (kN/m ³)	Cu (kPa)	c'(kPa)	ϕ'	E' (kPa)
0	5	19	29	0	25	18
5	15	21	57	20	28	30
15	30	21	72	40	28	40

Parametrii “M2” sunt obținuți din parametrii caracteristici, reduși cu factorul de proiectare prevăzut de Eurocod 7:

z1 (m from g.l.)	z2 (m from g.l.)	γ (kN/m ³)	Cu (kPa)	c'(kPa)	ϕ'	E' (kPa)
0	5	19	21	0	20	18
5	15	21	41	16	23	30
15	30	21	51	32	23	40

Pentru analizele următoare cu privire la lucrările temporare și permanente, aceste materiale au fost de asemenea modelate numai pentru condițiile drenate.

4 REZISTENȚA MATERIALULUI

Proprietățile de rezistență de proiectare a materialelor structurale sunt sintetizate mai jos.

4.1 Armături

- Oțel de armătură: *B450C controlat de instituție*
 $f_{u_{nom}} = 540 \text{ MPa}$
 $f_{y_{nom}} = 450 \text{ MPa}$
- Oțel structural: *S 355*
 $f_{u_{nom}} = 510 \text{ MPa}$
 $f_{y_{nom}} = 355 \text{ MPa}$
- Toroane de sârmă pentru ancore:
Rezistența caracteristică de rupere la întindere $f_{ptk} \geq 1860 \text{ N/mm}^2$
Limita de curgere la întindere de 0,1 % $f_{p1k} \geq 1670 \text{ N/mm}^2$

4.2 Beton

- Tunelul artificial și portalul tunelului: *Clasa de rezistență C30/35*
- Piloni și picior de reazem: *Clasa de rezistență C25/30*

5 CRITERIILE DE PROIECTARE ȘI ANALIZA STRUCTURILOR TEMPORARE

5.1 Descrierea structurilor temporare pentru intrarea tunelului

Pământul este excavat la adâncimea cerută cu ziduri de sprijin și ancore care suportă solul pe margini. Zidurile de sprijin sunt constituite din piloni găuriți din beton armat cu un diametru de 1200 mm și o lungime de la 15 m la 28 m. Distanța între piloni va fi de 1,3 m. Pilonii sunt conectați la partea superioară de un picior de reazem din beton armat care are dimensiunile 1,1 x 1,5 m.

Ancorele constau din găuri forate cu toroane de oțel precomprimat cimentate care se extind de la fața zidului la o zonă de ancoră localizată în spatele planurilor de ruptură potențială în solul rezemat. Se vor prevedea mai multe nivele de ancore în funcție de adâncimea excavației și de parametrii geotehnici ai solului. Pasul transversal între ancore va fi de 1,3 m și acestea vor fi în opoziție la diferite nivele cu grinzile de beton armat cu dimensiunile de 60 x 70 cm.

Conductele de drenaj suborizontal sunt instalate de-a lungul zidurilor de sprijin pentru a disipa presiunea hidrolică.

Fazele de construcție a zidurilor de sprijin sunt după cum urmează: :

1. Executarea pilonilor găuriți din beton pe ambele laturi ale viitorului tunel artificial;
2. Decaparea pilonilor la partea superioară;
3. Realizarea unei grinzi de coronament din beton armat la partea superioară a pilonilor;
4. Plasarea nivelului de toroane și realizarea grinzii din beton armat de la partea superioară;
5. Excavarea la nivelul ancorelor;
6. Plasarea nivelului de toroane și realizarea grinzii de contrast din beton armat;
7. Dacă este necesar se repetă etapele 4 și 5;
8. Excavarea până la adâncimea finală;
9. Excavarea și construirea radierului de tunel pentru tunelul artificial;
10. Construirea coronamentului tunelului și a pilonilor pentru tunelul artificial

5.2 Criteriile de proiectare

Proiectarea structurilor de reazem se face atât pentru starea limită extremă (ULS) cât și pentru starea limită de deservire (SLS).

5.2.1 Stările limită extreme

Sunt luate în considerare următoarele stări limită

Tip ULS – STR :

- Ruperea unui element structural precum zidurile, ancorajele, grinzile de contravântuire sau contrafișele sau ruperea legăturii dintre asemenea elemente;

Tipuri ULS – GEO, UPL și HYD :

- Ruperea prin rotire sau translație a zidului sau a părților din acesta;
- Ruperea din lipsa echilibrului vertical;
- Ruperea prin dislocare hidrolică și afuiere;
- Pierdere de stabilitate globală;
- Rupere combinată în teren și în elementul structural.

Când se consideră o stare limită de rupere sau de deformare excesivă a unui element structural sau secțiune a terenului (STR și GEO), se va verifica dacă:

$$Ed \leq Rd$$

Abordarea 1 de proiectare

Analiza ULS – STR este efectuată cu următoarea combinație de seturi de factori parțiali:

Combinația 1: A1 + M1 + R1.

Analiza ULS – GEO este efectuată cu următoarea combinație de seturi de factori parțiali:

Combinația 2: A2 + M2 + R1

REHABILITATION OF THE RAILWAY LINE BRASOV – SIMERIA, COMPONENT PART OF IV PAN-EUROPEAN CORRIDOR FOR THE TRAINS CIRCULATION WITH MAXIMUM SPEED OF 160 KM/H.

Pentru verificarea stărilor limită structurale (STR) și geotehnice (GEO), în tabelele următoare sunt sintetizați factorii parțial recomandați de Eurocod 7 și factorii de corelație

USL – Factorul parțial privind acțiunile și solul factorului parțial							
	Acțiunea γ_F				Parametrii solului (γ_m)		
	<i>Permanentă</i>		<i>Variabilă</i>				
	Nefavorabilă	Favorabilă	Nefavorabilă	Favorabilă	tan ϕ'	c'	c _u
STR (A1+M1)	1.35	1.00	1.50	0.00	1.00	1.00	1.00
GEO (A2+M2)	1.00	1.00	1.30	0.00	1.25	1.25	1.40

USL – Factor parțial de rezistență	
Rezistența	Factori parțiali de rezistență (γ_R)
Ruptură de elemente structurale ale zidului	$\gamma_R = 1$
Ruptură structurală a ancorajelor	$\gamma_R = 1$
Ruptură prin rotire sau translație a zidului	$\gamma_R = 1$
Ruptură prin dislocare hidraulică și afuire	$\gamma_R = 1$
Pierdere de stabilitate generală	$\gamma_R = 1$
Ruptură prin smulgerea ancorajelor	Temporară $\gamma_R = 1.1$
	Permanentă $\gamma_R = 1.1$

REHABILITATION OF THE RAILWAY LINE BRASOV – SIMERIA, COMPONENT PART OF IV PAN-EUROPEAN CORRIDOR FOR THE TRAINS CIRCULATION WITH MAXIMUM SPEED OF 160 KM/H.

5.2.2 Stările limită de deservire

Sunt luate în considerare următoarele stări limită:

SLS:

- Mișcarea structurii de reazem, care poate cauza prăbușirea sau afecta aspectul sau utilizarea eficientă a structurii.

Verificarea stărilor limită de deservire va cere ca:

$$Ed \leq Rd$$

Valorile factorilor parțiali pentru SLS sunt egale cu 1,0 atât pentru acțiuni cât și pentru parametrii solului, așa cum sunt recomandate de Eurocod 7 și rezumate în tabelul următor.

Acțiunea γ_F				Parametrii solului (γ_m)		
<u>Permanentă</u>		<u>Variabilă</u>				
Nefavorabilă	Favorabilă	Nefavorabilă	Favorabilă	$\tan \varphi'$	c'	c_u
1.00	1.00	1.00	1.00	1.00	1.00	1.00

5.2.3 Metoda de calcul

Analiza structurilor de sprijin este efectuată cu programul PARATIE versiunea 7.0 (CEAS Srl). Programul folosește pentru teren o comportare plastică-elastică și este în stare să urmărească întregul proces de construire. În tabelul următor sunt rezumate fazele de calcul pentru modelarea zidurilor de sprijin:

Fazele de calcul pentru zidurile de sprijin	
Faza	Descriere
1	Condiția geostatică inițială
2	Construirea zidului rezemat pe piloni
3	Excavarea la nivelul I de ancore
4	Instalarea ancorei I cu forța inițială egală cu 150 kN
5	Excavarea la nivelul II de ancore
6	Instalarea ancorei II cu forța inițială egală cu 150 kN
7	Excavarea la nivelul III de ancore
8	Instalarea ancorei III cu forța inițială egală cu 300 kN
7	Excavarea la nivelul IV de ancore
8	Instalarea ancorei IV cu forța inițială egală cu 300 kN

5.3 Cazuri analizate și rezultate

5.3.1 Secțiuni reprezentative

Analiza zidurilor de sprijin este efectuată pentru 3 secțiuni reprezentative:

Secțiunea 1: Secțiunea cu înălțime maximă a excavației, lungimea măsurată 213+187;

Secțiunea 2: Secțiunea la lungimea măsurată 213+170;

Secțiunea 3: Secțiunea la lungimea măsurată 213+163.

Secțiunea 1:

Secțiune și lungime măsurată	Lungimea măsurată 213+187
Tipul de ziduri încastrate	Pilonii zidului $\phi = 1200\text{mm}$, $L = 28\text{m}$; distanțare 1.30 m
Suprasarcini	Suprasarcină variabilă = 20 kN/m
Straturi geotehnice	De la 0 m la 5m h.c.
	De la 5 m la 15m h.c.
	De la 15 m la 30 m h.c.
Baza excavației	Z1 = 15.3 m de la grinda superioară (radierul tunelului)
Ancoră	Nivel I de ancoră H1 = 0.5 m
	Nivel II de ancoră H2 = 4.0 m
	Nivel III de ancoră H3 = 8 m
	Nivel IV de ancoră H4 = 12 m
Distanțarea transversală a ancorelor	1.3 m
Apa freatică	2 m de la h.c.

REHABILITATION OF THE RAILWAY LINE BRASOV – SIMERIA, COMPONENT PART OF IV PAN-EUROPEAN CORRIDOR FOR THE TRAINS CIRCULATION WITH MAXIMUM SPEED OF 160 KM/H.

Secțiunea 2:

Secțiune și lungime măsurată	Lungimea măsurată 213+170
Tipul de ziduri încastrate	Pilonii zidului $\phi = 1200\text{mm}$; L=25m; distanțare 1.30 m
Suprasarcini	Suprasarcină variabilă = 20 kN/m
Straturi geotehnice	De la 0 m la 5m h.c.
	De la 5 m la 15m h.c.
	De la 15 m la 30 m h.c.
Baza excavației	Z1 = 9.5 m de la grinda superioară (radierul tunelului)
Ancoră	Nivel I de ancoră H1 = 0.5 m
	Nivel II de ancoră H2 = 4.0 m
	Nivel III de ancoră H3 = 8 m
Distanțarea transversală a ancorelor	1.3 m
Apa freatică	2 m de la h.c.

Secțiunea 3:

Secțiune și lungime măsurată	Lungimea măsurată 213+163
Tipul de ziduri încastrate	Pilonii zidului $\phi = 1200\text{mm}$; L= 22m; distanțare 1.30 m
Suprasarcini	Suprasarcină variabilă = 20 kN/m
Straturi geotehnice	De la 0 m la 5m h.c.
	De la 5 m la 15m h.c.
	De la 15 m la 30 m h.c.
Baza excavației	Z1 = 7.5 m de la grinda superioară (radierul tunelului)
Ancoră	Nivel I de ancoră H1 = 0.5 m
	Nivel II de ancoră H2 = 4.0 m
Distanțarea transversală a ancorelor	1.3 m
Apa freatică	2 m de la h.c.

REHABILITATION OF THE RAILWAY LINE BRASOV – SIMERIA, COMPONENT PART OF IV PAN-EUROPEAN CORRIDOR FOR THE TRAINS CIRCULATION WITH MAXIMUM SPEED OF 160 KM/H.

5.3.2 Date de intrare pentru analiză

În tabelele următoare sunt prezentați parametrii geotehnici pentru analizele executate. În mod conservator, analizele au fost efectuate cu parametri drenaji :

Strat	Combi-nația	γ [kN/m ³]	c' [kPa]	ϕ' [°]	E'vc [Mpa]	E'ur [Mpa]
De la 0.0 m la 5.0 m	M1	19	0	25	18	23
	M2	19	0	20	18	23
<p>γ = greutatea specifică totală c' = coeziunea ϕ' = unghiul de frecare E'vc = modulul elastic E'ur = modulul elastic în condiția de descărcare / reîncărcare</p>						

Strat	Combi-nația	γ [kN/m ³]	c' [kPa]	ϕ' [°]	E'vc [Mpa]	E'ur [Mpa]
De la 5.0m la 15.0 m	M1	21	20	28	20	25
	M2	21	16	23	20	25
<p>γ = greutatea specifică totală c' = coeziunea ϕ' = unghiul de frecare E'vc = modulul elastic E'ur = modulul elastic în condiția de descărcare / reîncărcare</p>						

REHABILITATION OF THE RAILWAY LINE BRASOV – SIMERIA, COMPONENT PART OF IV PAN-EUROPEAN CORRIDOR FOR THE TRAINS CIRCULATION WITH MAXIMUM SPEED OF 160 KM/H.

Strat	Combi-nația	γ [kN/m ³]	c' [kPa]	ϕ' [°]	E'_{vc} [Mpa]	E'_{ur} [Mpa]
De la 15.0m la 30.0 m	M1	21	40	28	30	35
	M2	21	32	23	30	35
γ = greutatea specifică totală c' = coeziunea ϕ' = unghiul de frecare E'_{vc} = modulul elastic E'_{ur} = modulul elastic în condiția de descărcare / reîncărcare						

În tabelele următoare sunt rezumate valorile coeficienților presiunii active a pământului K_a și a coeficienților presiunii pasive a pământului K_p .

Strat	Combi-nația	k_{ah}	k_{ph}
De la 0.0 m la 5.0 m	M1	0.359	3.319
	M2	0.44	2.511

Strat	Combi-nația	k_{ah}	k_{ph}
De la 5.0m la 15.0 m	M1	0.317	3.929
	M2	0.389	2.948

Strat	Combi-nația	k_{ah}	k_{ph}
De la 15.0m la 30.0 m	M1	0.317	3.929
	M2	0.389	2.948

5.3.3 Rezultatele analizelor

În tabelele următoare sunt sintetizate rezultatele principale pentru analizele efectuate. Rezultatele se referă la 1 metru de zid rezemat pe piloni. Tensiunile sunt ca valori nominale

REHABILITATION OF THE RAILWAY LINE BRASOV – SIMERIA, COMPONENT PART OF IV PAN-EUROPEAN CORRIDOR FOR THE TRAINS CIRCULATION WITH MAXIMUM SPEED OF 160 KM/H.

5.3.3.1 Secțiunea 1 (Combinăția GEO)

Înfășurătoarea momentului de încovoiere

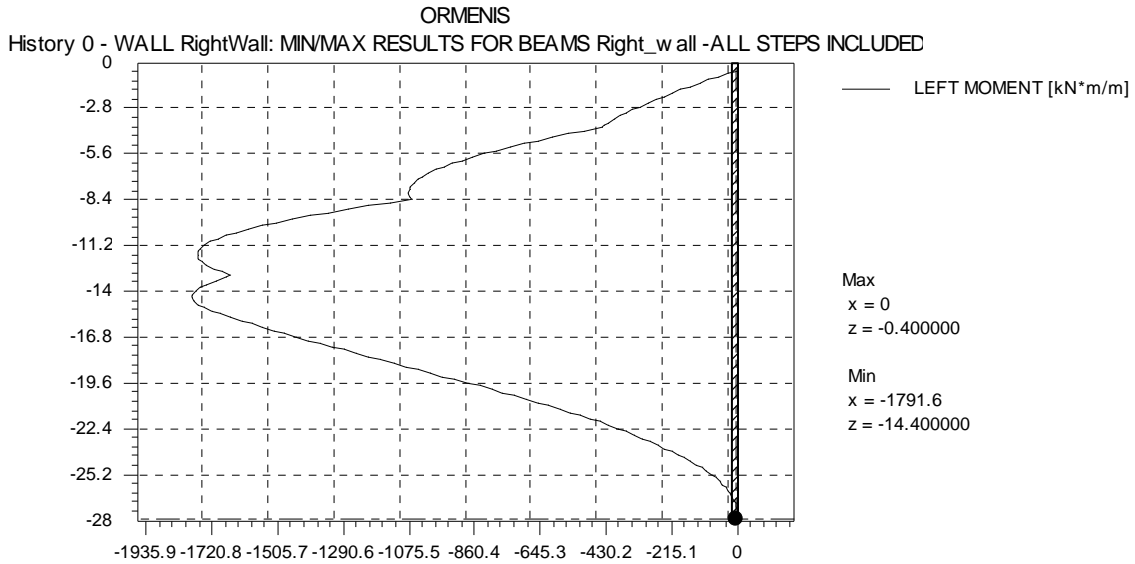

PARATIE 7.0 - Ce.A.S. s.r.l

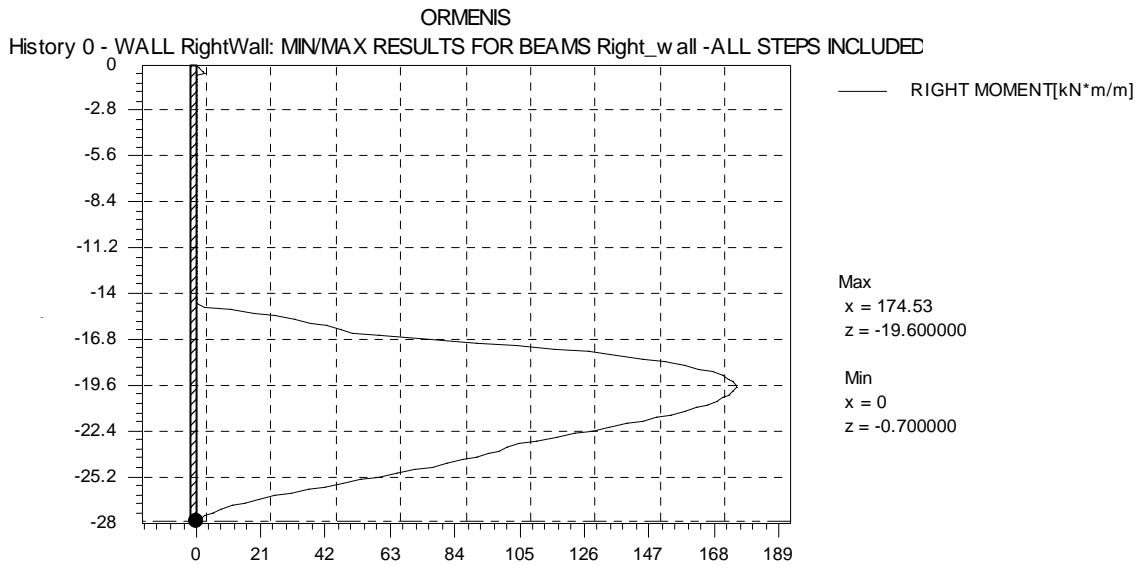

PARATIE 7.0 - Ce.A.S. s.r.l

REHABILITATION OF THE RAILWAY LINE BRASOV – SIMERIA, COMPONENT PART OF IV PAN-EUROPEAN CORRIDOR FOR THE TRAINS CIRCULATION WITH MAXIMUM SPEED OF 160 KM/H.

Înfășurătoarea de forfecare

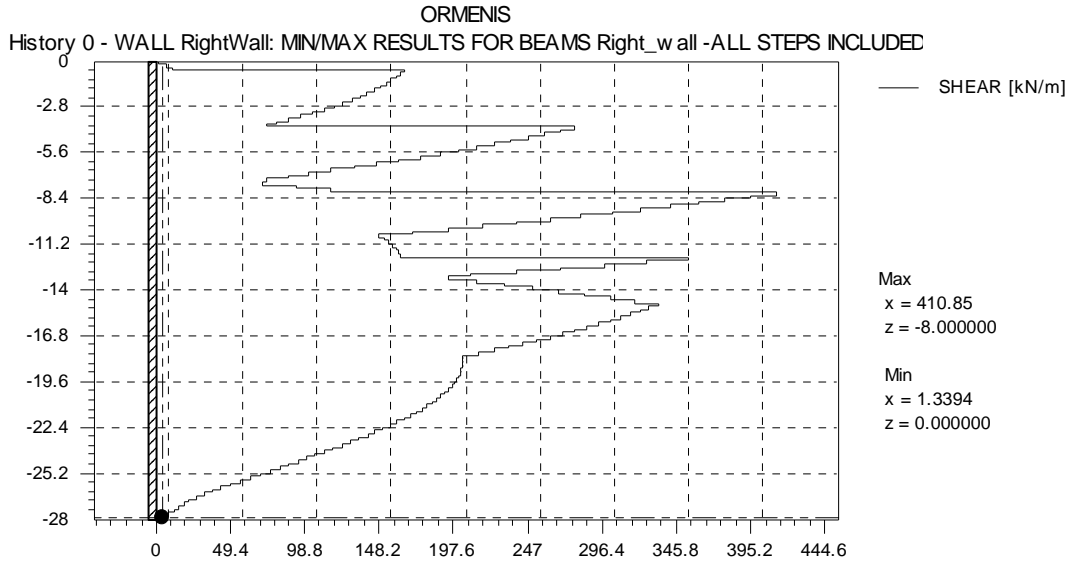

PARATIE 7.0 - Ce.A.S. s.r.l

Deplasarea

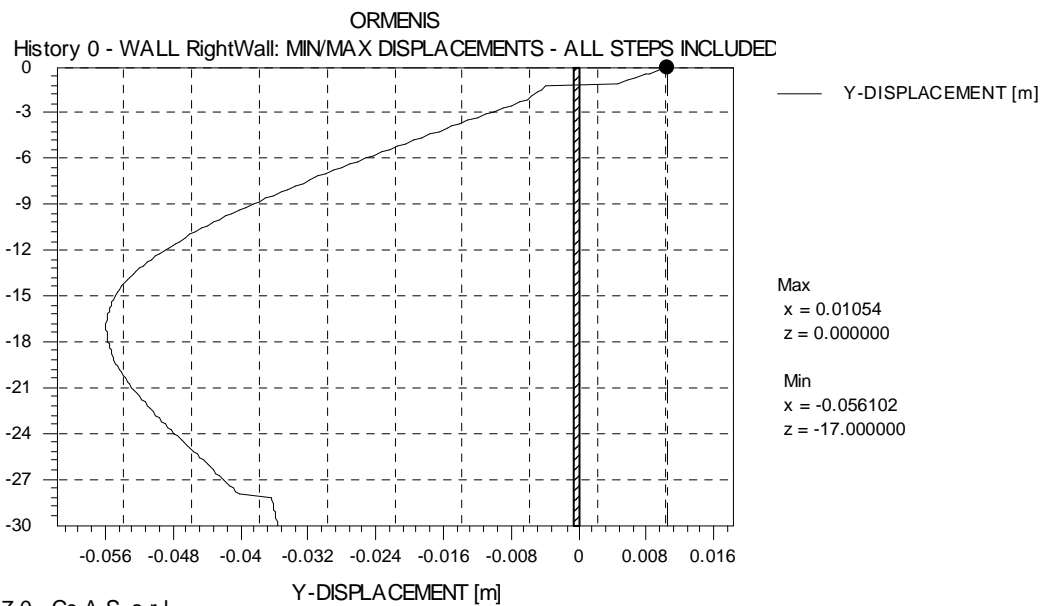

PARATIE 7.0 - Ce.A.S. s.r.l

REHABILITATION OF THE RAILWAY LINE BRASOV – SIMERIA, COMPONENT PART OF IV PAN-EUROPEAN CORRIDOR FOR THE TRAINS CIRCULATION WITH MAXIMUM SPEED OF 160 KM/H.

5.3.3.2 Secțiunea 1 (Combi-nația STR)

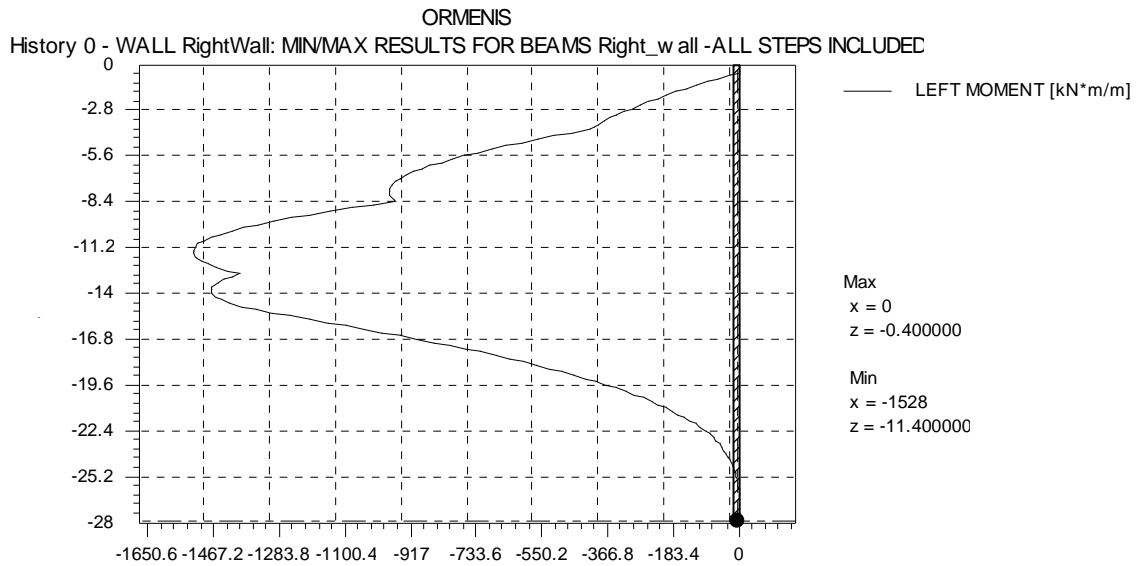

PARATIE 7.0 - Ce.A.S. s.r.l

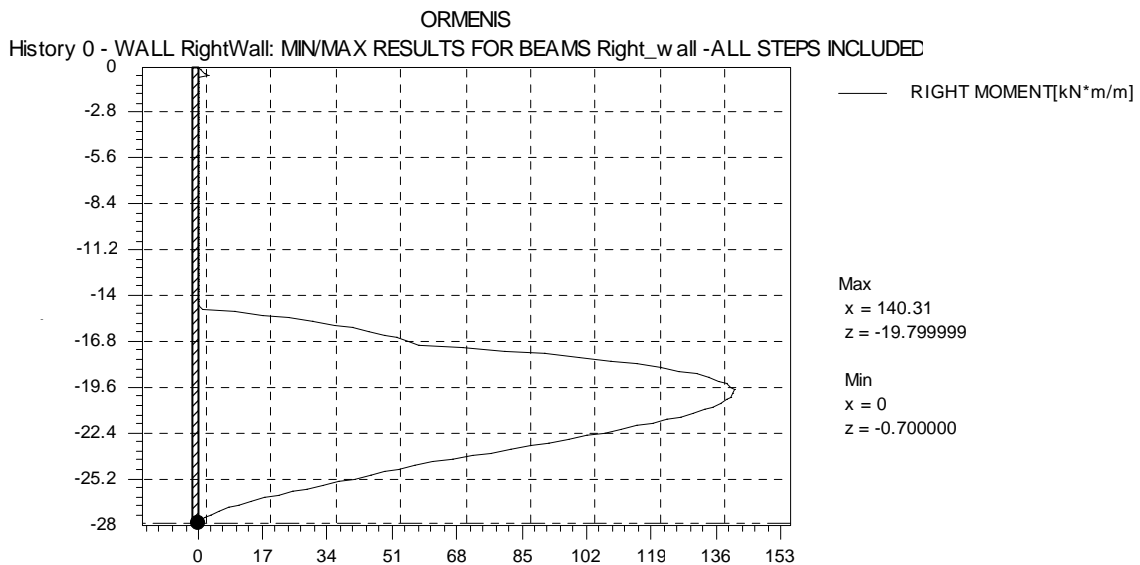

PARATIE 7.0 - Ce.A.S. s.r.l

REHABILITATION OF THE RAILWAY LINE BRASOV – SIMERIA, COMPONENT PART OF IV PAN-EUROPEAN CORRIDOR FOR THE TRAINS CIRCULATION WITH MAXIMUM SPEED OF 160 KM/H.

Înfășurătoarea de forfecare

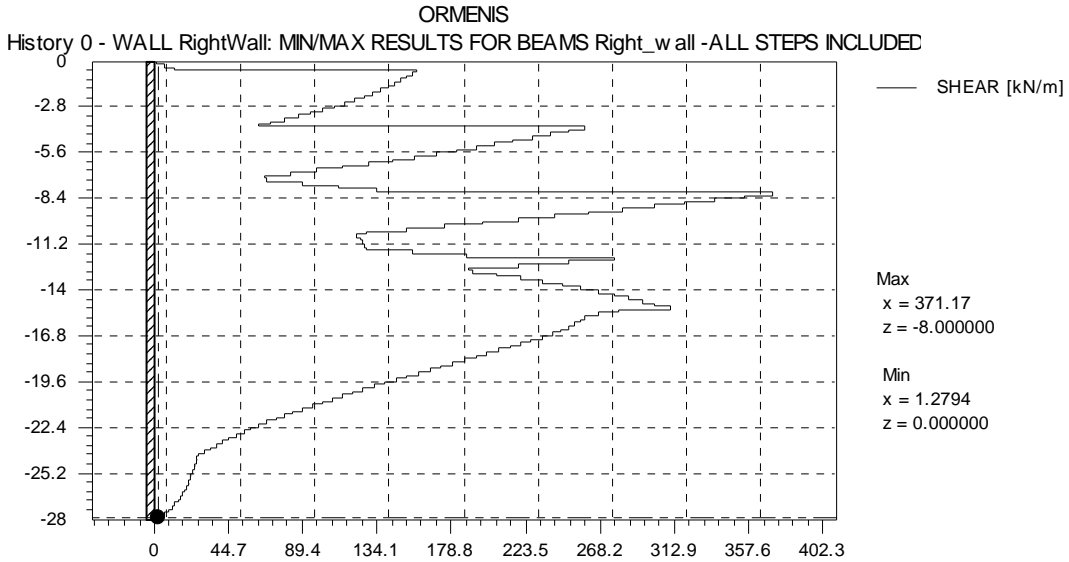

PARATIE 7.0 - Ce.A.S. s.r.l

Deplasarea

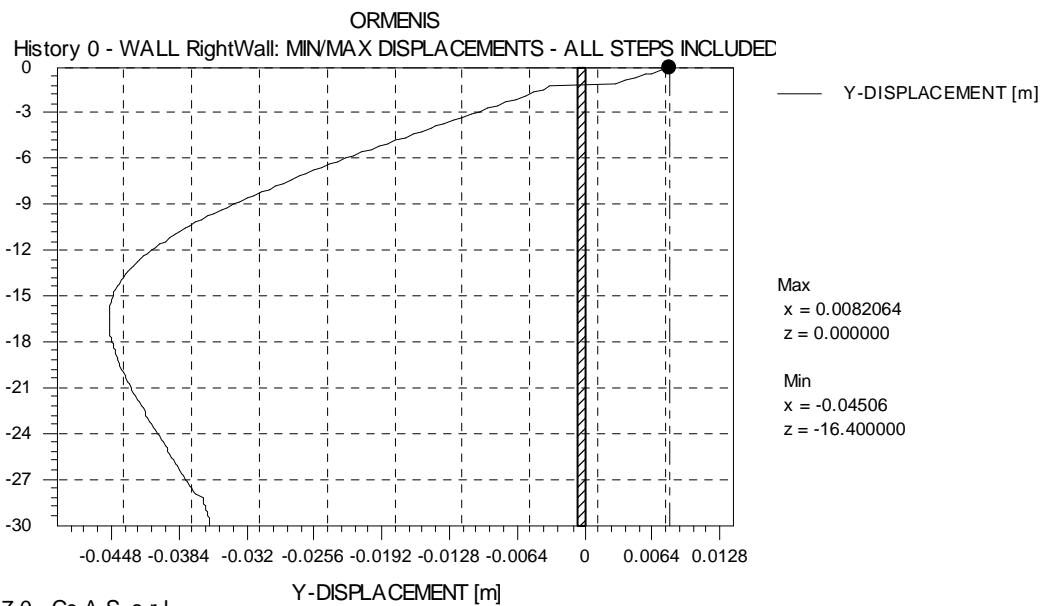

PARATIE 7.0 - Ce.A.S. s.r.l

REHABILITATION OF THE RAILWAY LINE BRASOV – SIMERIA, COMPONENT PART OF IV PAN-EUROPEAN CORRIDOR FOR THE TRAINS CIRCULATION WITH MAXIMUM SPEED OF 160 KM/H.

5.3.3.3 Secțiunea 2 (Combinăția GEO)

Înfășurătoarea momentului de încovoiere

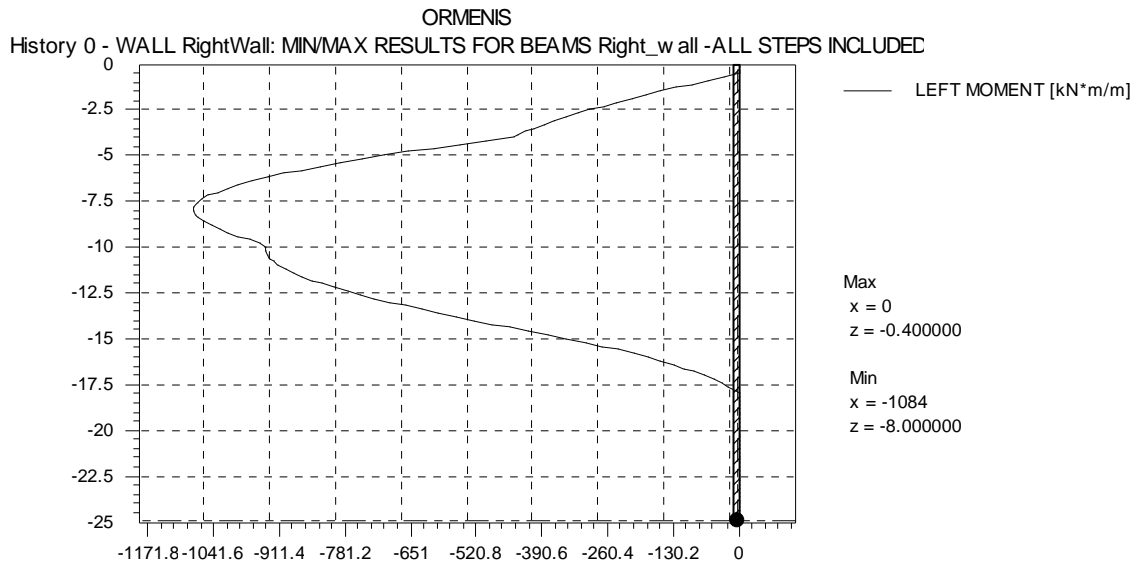

PARATIE 7.0 - Ce.A.S. s.r.l

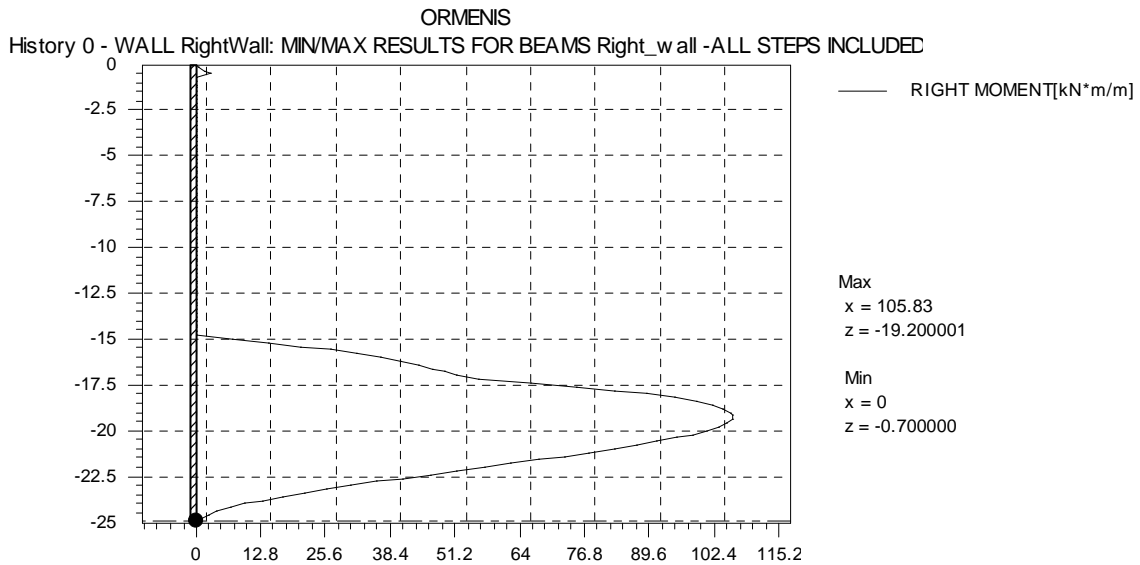

PARATIE 7.0 - Ce.A.S. s.r.l

REHABILITATION OF THE RAILWAY LINE BRASOV – SIMERIA, COMPONENT PART OF IV PAN-EUROPEAN CORRIDOR FOR THE TRAINS CIRCULATION WITH MAXIMUM SPEED OF 160 KM/H.

Înfășurătoarea de forfecare

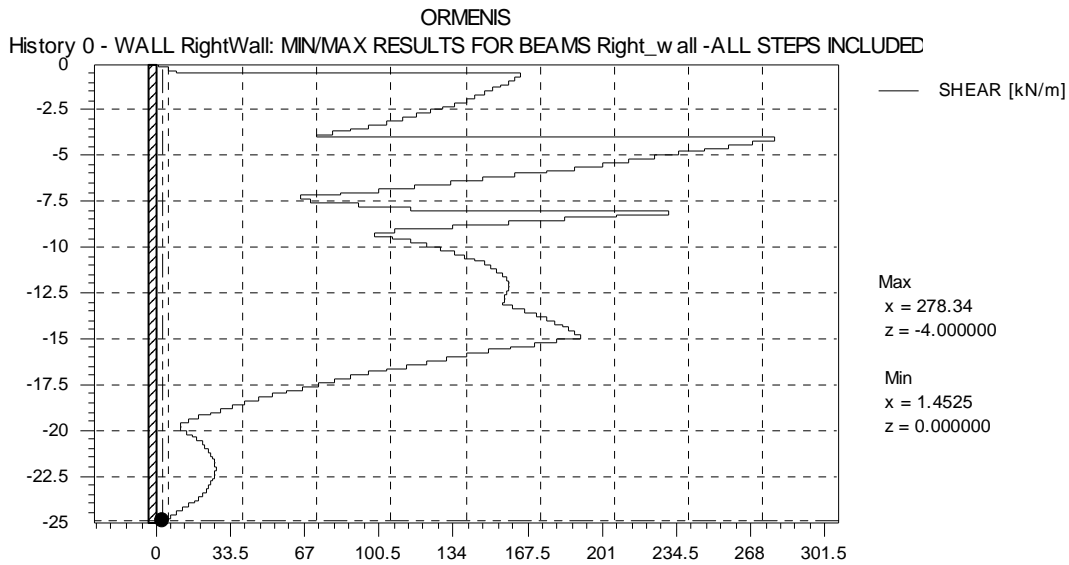

PARATIE 7.0 - Ce.A.S. s.r.l

Deplasarea

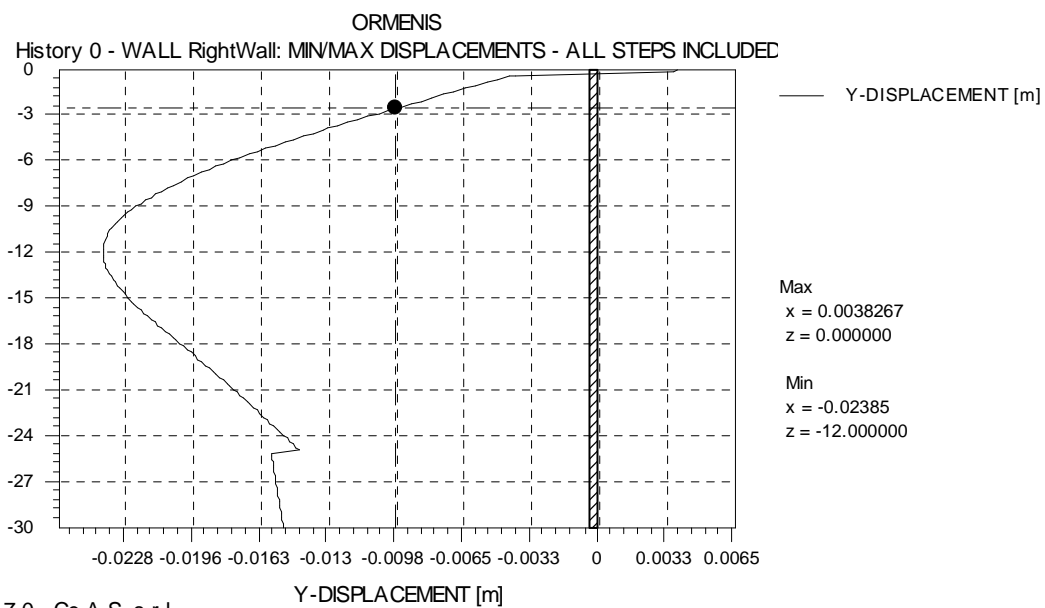

PARATIE 7.0 - Ce.A.S. s.r.l

REHABILITATION OF THE RAILWAY LINE BRASOV – SIMERIA, COMPONENT PART OF IV PAN-EUROPEAN CORRIDOR FOR THE TRAINS CIRCULATION WITH MAXIMUM SPEED OF 160 KM/H.

5.3.3.4 Secțiunea 2 (Combi-nația STR)

Înfășurătoarea momentului de încovoiere

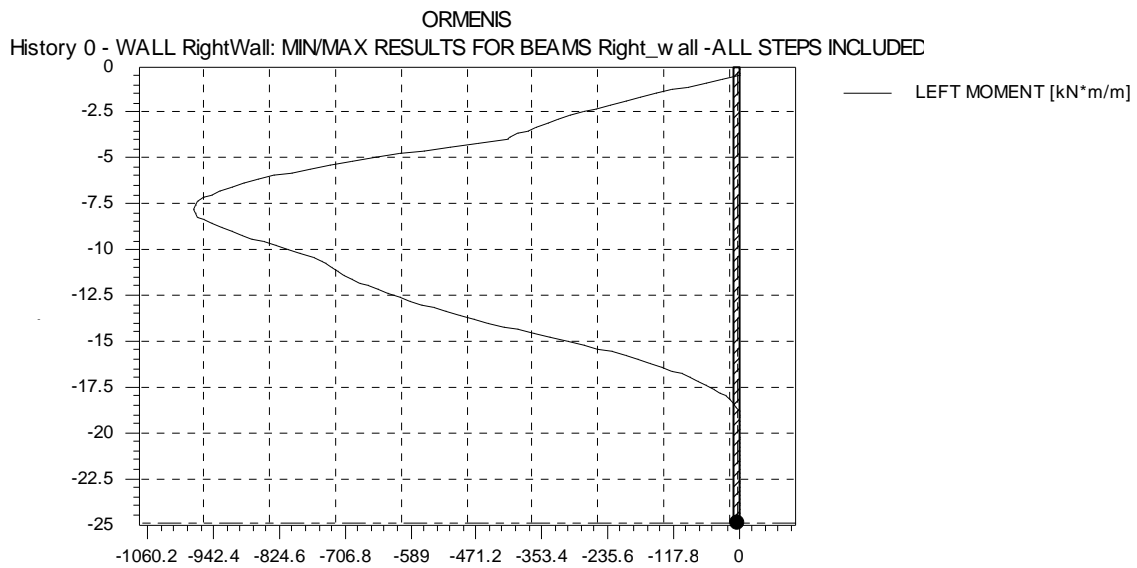

PARATIE 7.0 - Ce.A.S. s.r.l

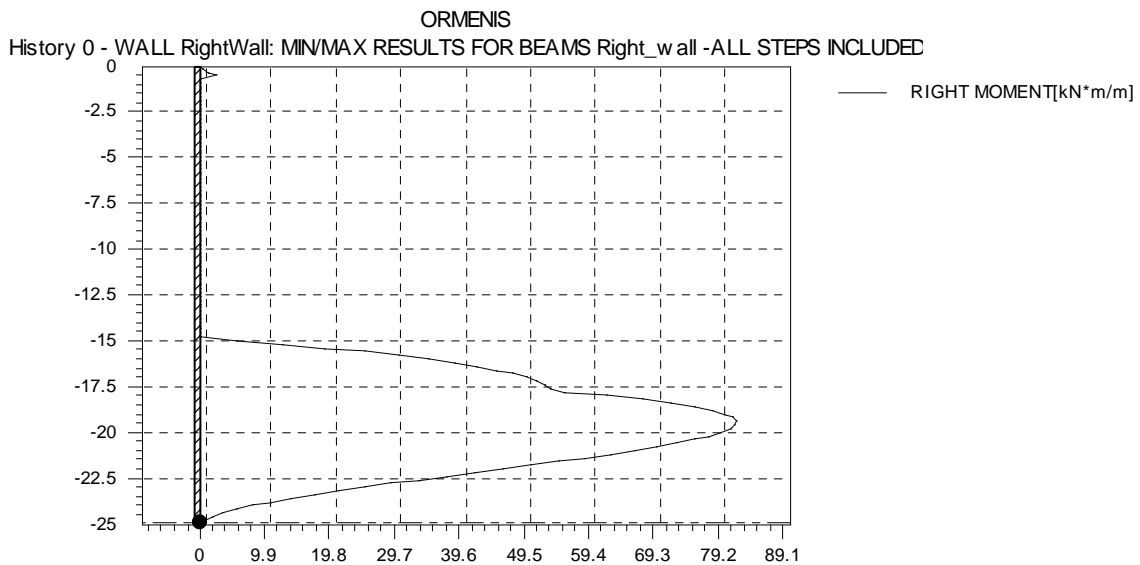

PARATIE 7.0 - Ce.A.S. s.r.l

REHABILITATION OF THE RAILWAY LINE BRASOV – SIMERIA, COMPONENT PART OF IV PAN-EUROPEAN CORRIDOR FOR THE TRAINS CIRCULATION WITH MAXIMUM SPEED OF 160 KM/H.

Înfășurătoarea de forfecare

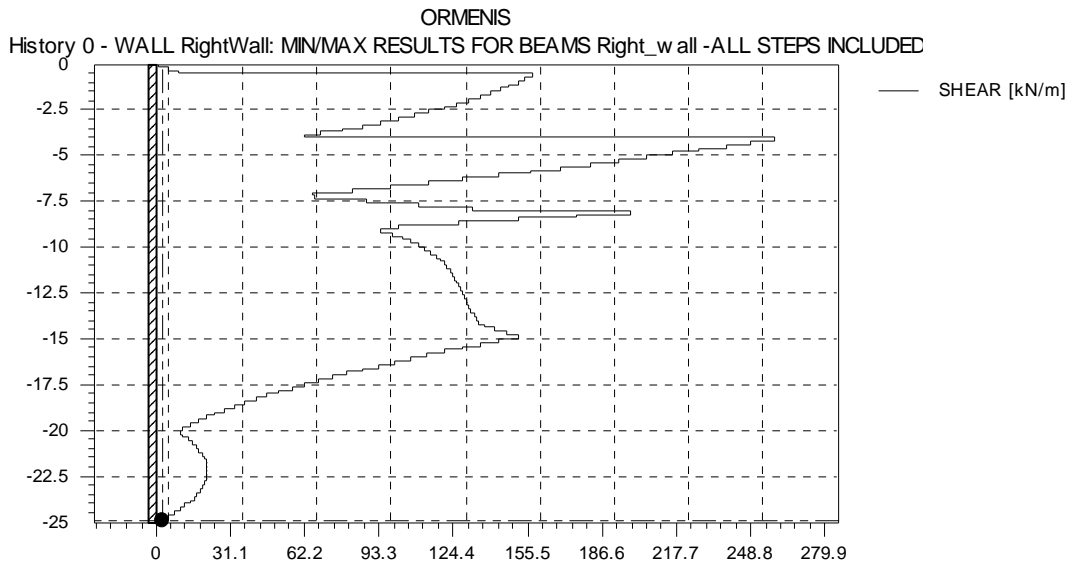

PARATIE 7.0 - Ce.A.S. s.r.l

Deplasarea

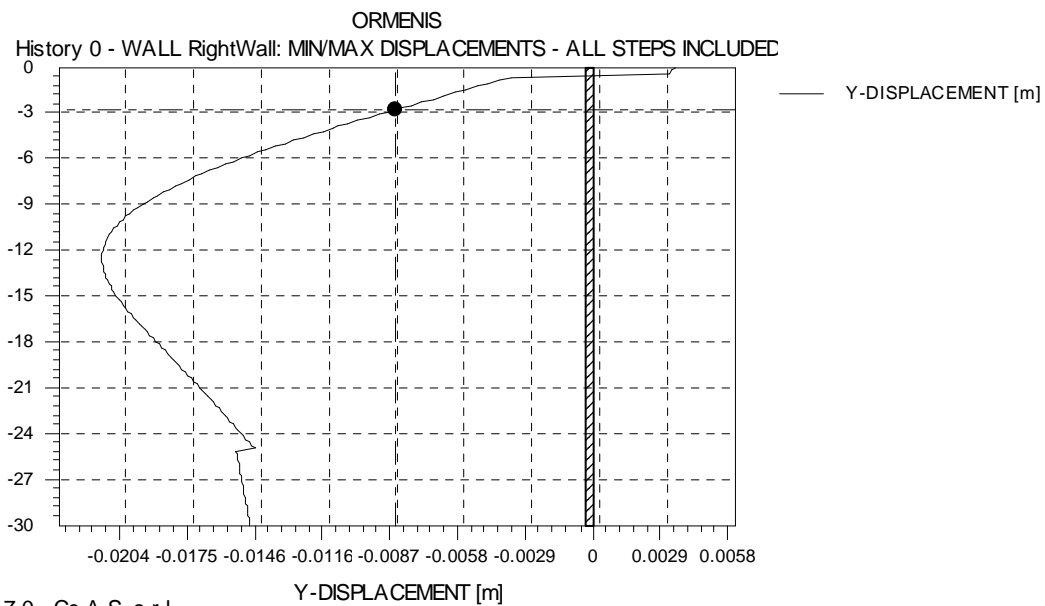

PARATIE 7.0 - Ce.A.S. s.r.l

REHABILITATION OF THE RAILWAY LINE BRASOV – SIMERIA, COMPONENT PART OF IV PAN-EUROPEAN CORRIDOR FOR THE TRAINS CIRCULATION WITH MAXIMUM SPEED OF 160 KM/H.

5.3.3.5 Secțiunea 3 (Combi-nația GEO)

Înfășurătoarea momentului de încovoiere

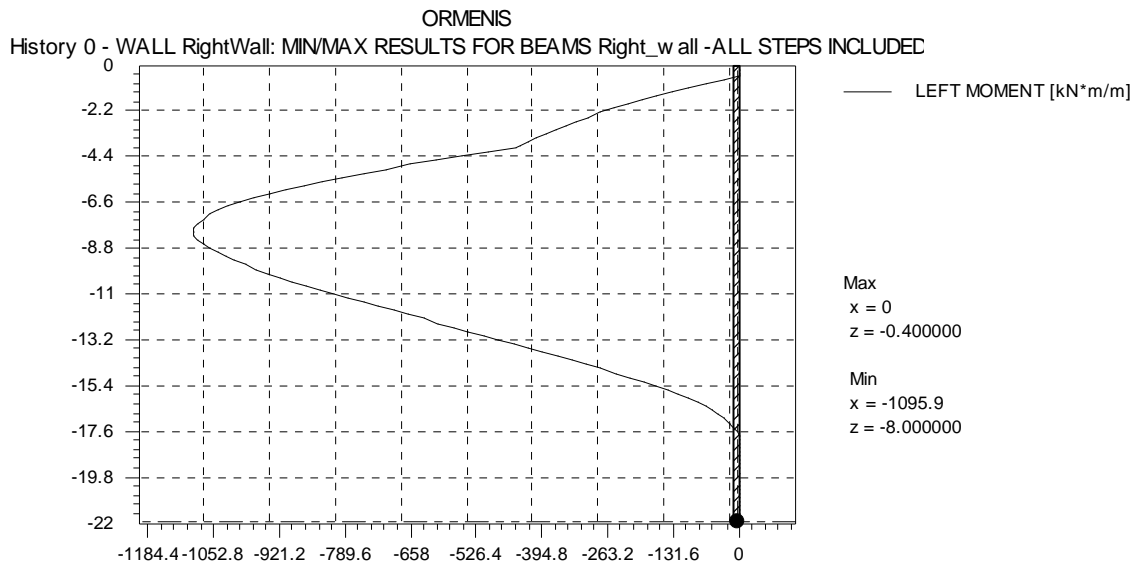

PARATIE 7.0 - Ce.A.S. s.r.l

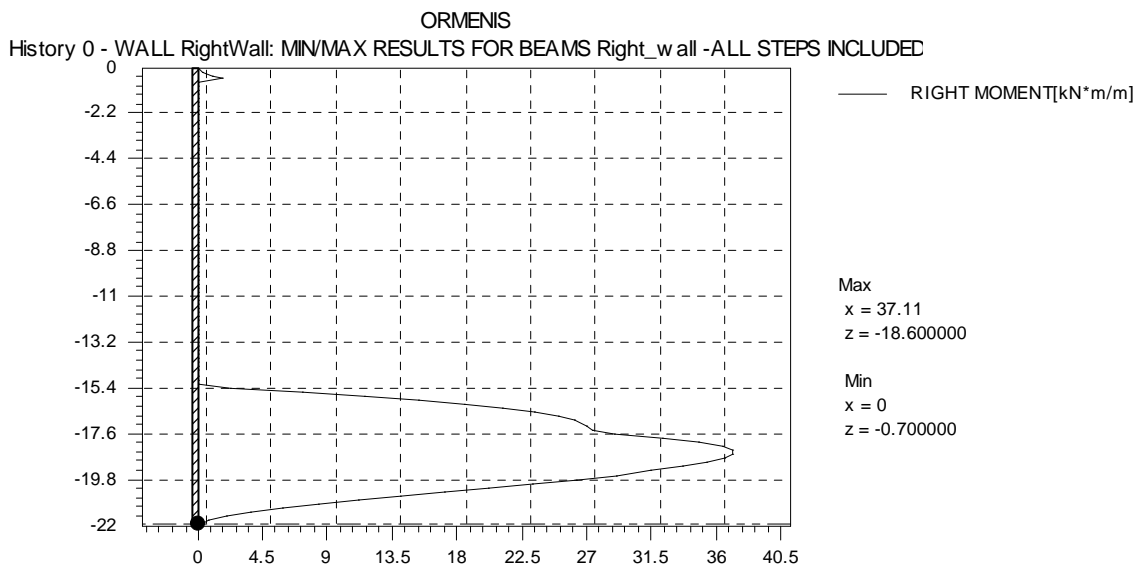

PARATIE 7.0 - Ce.A.S. s.r.l

REHABILITATION OF THE RAILWAY LINE BRASOV – SIMERIA, COMPONENT PART OF IV PAN-EUROPEAN CORRIDOR FOR THE TRAINS CIRCULATION WITH MAXIMUM SPEED OF 160 KM/H.

Înfășurătoarea de forfecare

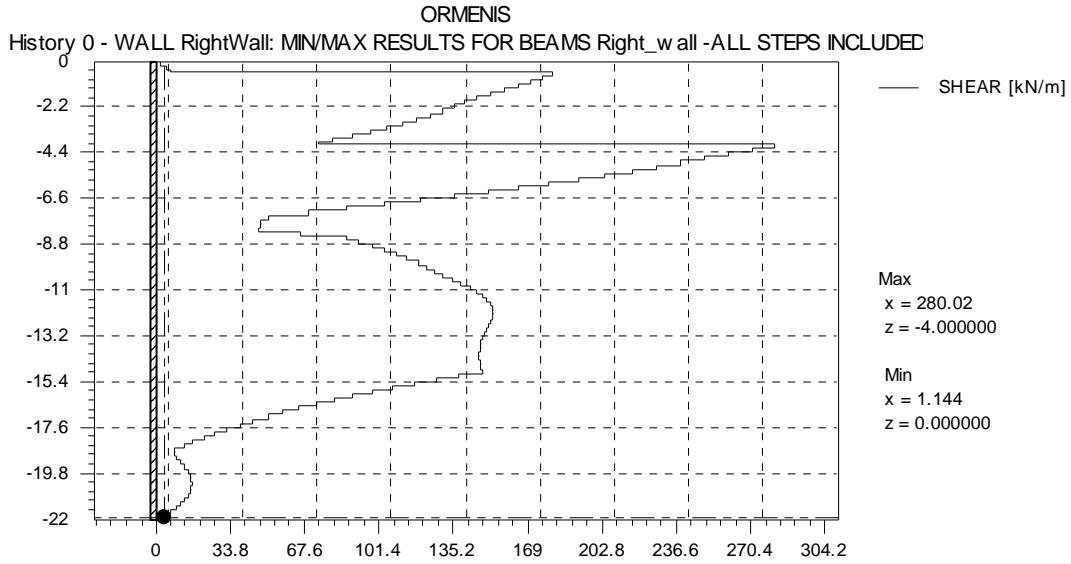

PARATIE 7.0 - Ce.A.S. s.r.l

Deplasarea

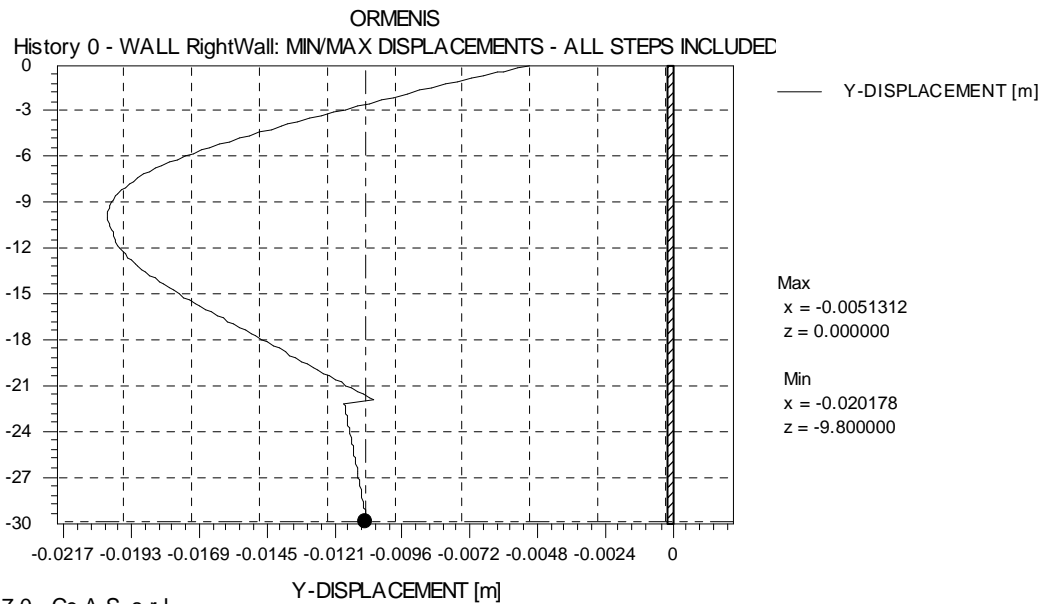

PARATIE 7.0 - Ce.A.S. s.r.l

REHABILITATION OF THE RAILWAY LINE BRASOV – SIMERIA, COMPONENT PART OF IV PAN-EUROPEAN CORRIDOR FOR THE TRAINS CIRCULATION WITH MAXIMUM SPEED OF 160 KM/H.

5.3.3.6 Secțiunea 3 (Combinăția STR)

Înfășurătoarea momentului de încovoiere

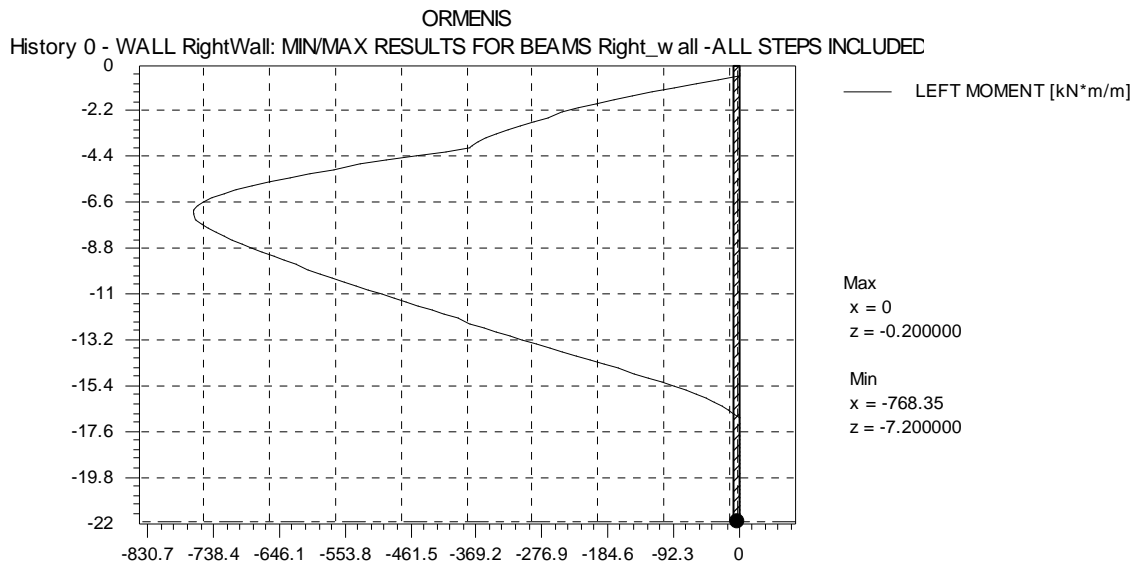

PARATIE 7.0 - Ce.A.S. s.r.l

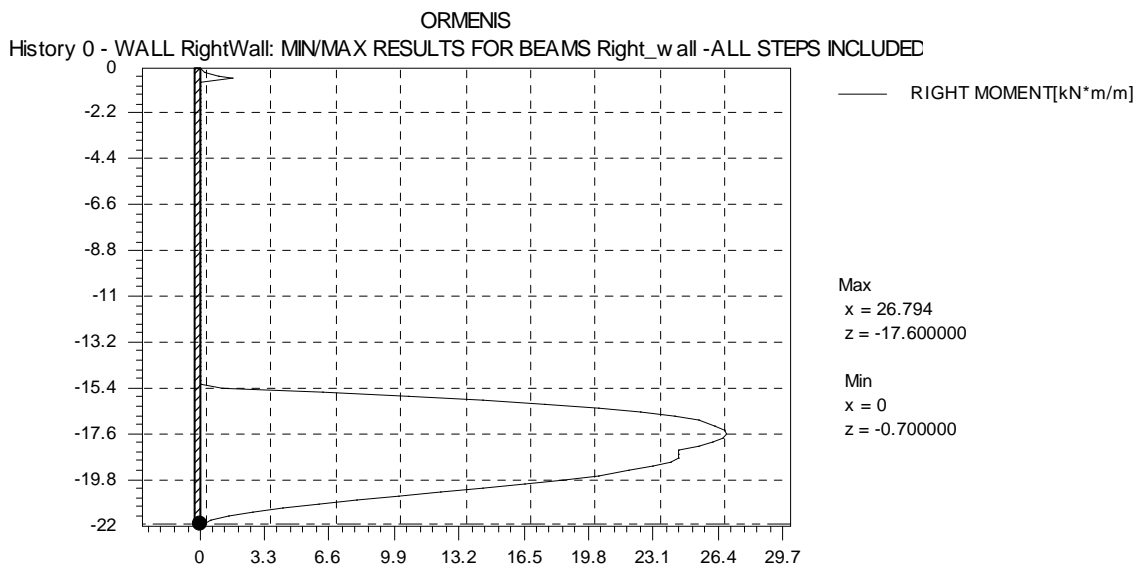

PARATIE 7.0 - Ce.A.S. s.r.l

REHABILITATION OF THE RAILWAY LINE BRASOV – SIMERIA, COMPONENT PART OF IV PAN-EUROPEAN CORRIDOR FOR THE TRAINS CIRCULATION WITH MAXIMUM SPEED OF 160 KM/H.

Înfășurătoarea de forfecare

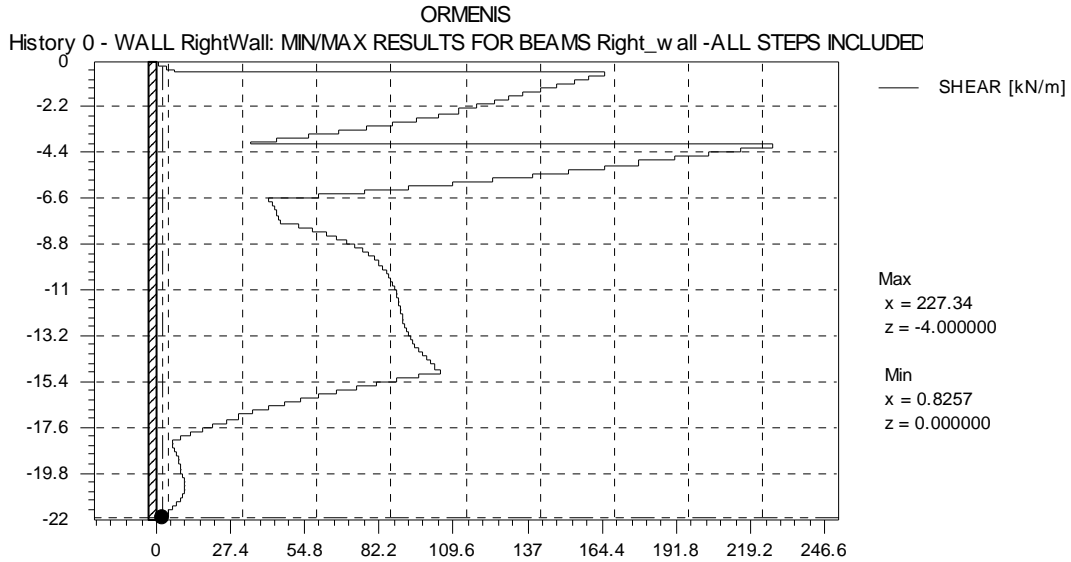

PARATIE 7.0 - Ce.A.S. s.r.l

Deplasarea

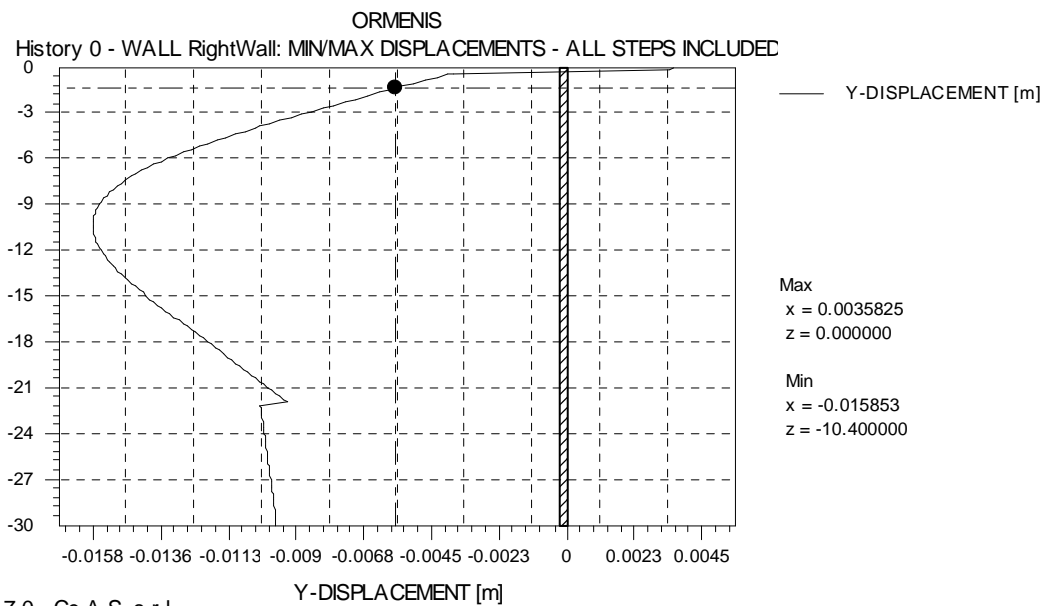

PARATIE 7.0 - Ce.A.S. s.r.l

5.3.4 Verificarea rezistenței elementelor structurale

În această secțiune este prezentată verificarea elementelor structurale. Toate verificările structurale sunt efectuate cu combinația ULS – STR și USL GEO.

5.3.4.1 Piloni

În tabelele următoare sunt sintetizate rezultatele repetării acțiunilor de încovoiere-axială (domeniul M-N) și verificările de forfecare pentru Secțiunea 1, 2 și 3. Pentru a obține valorile de proiectare, valorile luate prin Paratie sunt multiplicare cu distanțarea pilonilor (=1,30 m) și cu factorul parțial ULS privind efectele acțiunilor.

Verificările de forfecare a secțiunii circulare a pilonilor s-a referit la o secțiune rectangulară echivalentă, suprafața efectivă fiind obținută prin relația propusă de Buletinul CEB nr. 137, Anexa 5:

$$b_{w,eq} = 0,9 \cdot \Phi \text{ pilon} = 0,9 \cdot 120 = 108 \text{ cm}$$

$$h_{eq} = 0,45 \cdot \Phi \text{ pilon} + 0,64 \cdot (\Phi \text{ pilon} / 2 - c_p) + c_p = 96,0 \text{ cm}$$

Secțiunea 1 – Încovoierea cu forța axială								
	Secțiunea de verificat	Distanțare	M	Msd	Armare	Nsd	Mrd	S.F.
	m	m	KN*m/m	KN*m	n.	kN	KN*m	-
GEO	-14,4	1,3	1792	2330	35 ϕ 26	407	3151	1,35
STR	-11,4	1,3	1528	2682	35 ϕ 26	322	3129	1,17

Secțiunea 1 - Forfecare							
	Secțiunea de verificat	Distanțare	V	Vsd	Etrieri de grindă	Vrd	S.F.
	m	m	KN/m	KN	n.	KN*m	-
GEO	-8	1,3	410	533	Spiral ϕ 14/20 cm	1233	2,31
STR	-8	1,3	371	651	Spiral ϕ 14/20 cm	1233	1,89

REHABILITATION OF THE RAILWAY LINE BRASOV – SIMERIA, COMPONENT PART OF IV PAN-EUROPEAN CORRIDOR FOR THE TRAINS CIRCULATION WITH MAXIMUM SPEED OF 160 KM/H.

Secțiunea 2 – Încovoierea cu forța axială								
	Secțiunea de verificat	Distanțare	M	Msd	Armare	Nsd	Mrd	S.F.
	m	m	KN*m/m	KN*m	n.	kN	KN*m	-
GEO	-8	1,3	1084	1409	30 ϕ 26	226	2725	1,93
STR	-7,8	1,3	980	1720	30 ϕ 26	221	2724	1,58

Secțiunea 2 - Forfecare							
	Secțiunea de verificat	Distanțare	V	Vsd	Etrieri de grindă	Vrd	S.F.
	m	m	KN/m	KN	n.	KN*m	-
GEO	-4	1,3	278	361	Spiral ϕ 12/20 cm	794	2,20
STR	-4	1,3	258	453	Spiral ϕ 12/20 cm	794	1,75

Secțiunea 3 – Încovoierea cu forța axială								
	Secțiunea de verificat	Distanțare	M	Msd	Armare	Nsd	Mrd	S.F.
	m	m	KN*m/m	KN*m	n.	kN	KN*m	-
GEO	-8	1,3	1096	1425	26 ϕ 20	226	1564	1,10
STR	-7,2	1,3	768	1348	26 ϕ 20	204	1555	1,15

Secțiunea 3 - Forfecare							
	Secțiunea de verificat	Distanțare	V	Vsd	Etrieri de grindă	Vrd	S.F.
	m	m	KN/m	KN	n.	KN*m	-
GEO	-4	1,3	280	364	Spiral ϕ 12/20 cm	794	2,18
STR	-4	1,3	227	398	Spiral ϕ 12/20 cm	794	1,99

REHABILITATION OF THE RAILWAY LINE BRASOV – SIMERIA, COMPONENT PART OF IV PAN-EUROPEAN CORRIDOR FOR THE TRAINS CIRCULATION WITH MAXIMUM SPEED OF 160 KM/H.

5.3.4.2 Picioarele de reazem

Structura poate fi sintetizată cu o grindă simplu rezemată și supusă unei sarcini punctiforme la mijloc. Prin aceasta se formează încastrarea, în timp ce sarcina punctiformă este reprezentată de ancoră.

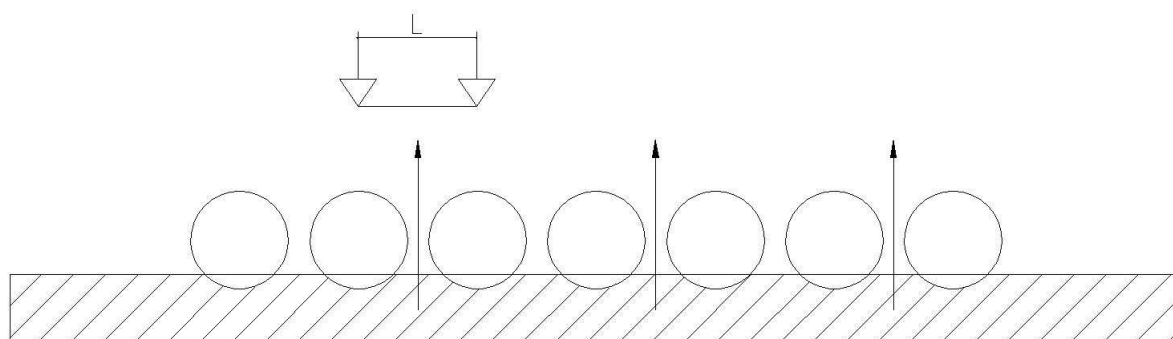

Secțiunea 1

	T	int.	α	Mx	My
	kPa	m	°	KN*m	KN*m
Nivel IV	695,5	1,3	22,5	208,8	86,5
Nivel III	777,9	1,3	22,5	233,6	96,7
Nivel II	454,5	1,3	22,5	136,5	56,5
Nivel I	313,3	1,3	22,5	94,1	39,0

Secțiunea 2

	T	int.	α	Mx	My
	kPa	m	°	KN*m	KN*m
Nivel III	606,0	1,3	22,5	182,0	75,4
Nivel II	434,4	1,3	22,5	130,4	54,0
Nivel I	337,6	1,3	22,5	101,4	42,0

REHABILITATION OF THE RAILWAY LINE BRASOV – SIMERIA, COMPONENT PART OF IV PAN-EUROPEAN CORRIDOR FOR THE TRAINS CIRCULATION WITH MAXIMUM SPEED OF 160 KM/H.

Secțiunea 3

	T	int.	α	Mx	My
	kPa	m	°	KN*m	KN*m
Nivel II	393,2	1,3	22,5	118,1	48,9
Nivel I	357,4	1,3	22,5	107,3	44,4

Caracteristici		
Materiale		
C 25/30		
fcd	Mpa	14,17
B450C		
fyd	MPa	391
Secțiunea		
b	cm	60
h	cm	70
As	cm ²	21.24
A's	cm ²	21.24
c	cm	5
d	cm	65
Msd _x	kN*m	233,6
Msd _y	kN*m	96.7

REHABILITATION OF THE RAILWAY LINE BRASOV – SIMERIA, COMPONENT PART OF IV PAN-EUROPEAN CORRIDOR FOR THE TRAINS CIRCULATION WITH MAXIMUM SPEED OF 160 KM/H.

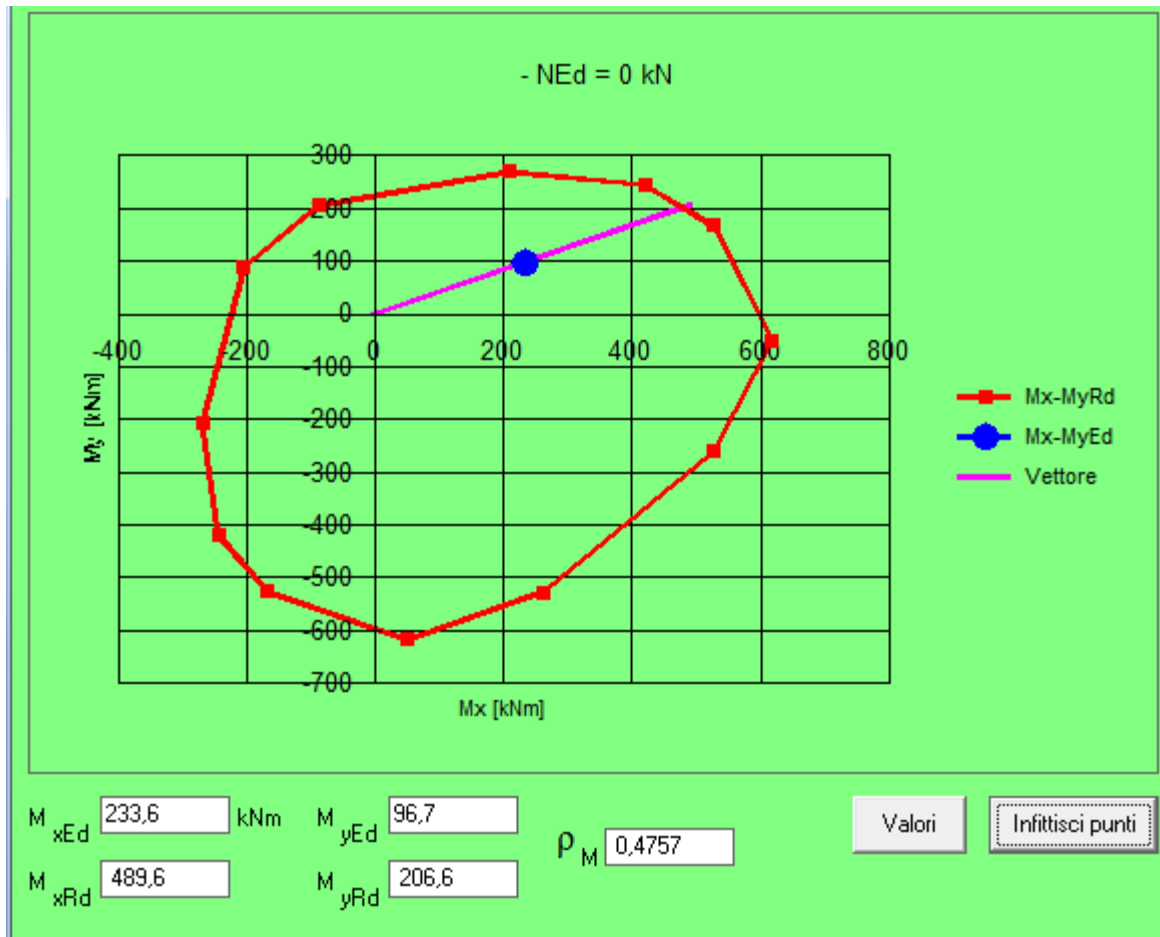

REHABILITATION OF THE RAILWAY LINE BRASOV – SIMERIA, COMPONENT PART OF IV PAN-EUROPEAN CORRIDOR FOR THE TRAINS CIRCULATION WITH MAXIMUM SPEED OF 160 KM/H.

Armare de forfecare

Caracteristici		
Materiale		
C 25/30		
fcd	Mpa	14,17
B450C		
fyd	MPa	391
Secțiunea		
b	cm	60
h	cm	70
As	cm ²	21.24
A's	cm ²	21.24
c	cm	5
d	cm	55
Tsd	kN*m	388.5
Ast	cm ² /m	11.31
ctgθ =		2,5
θ	(°)	20.4
V _{Rsd}	kN	880,96
V _{Rcd}	kN	996,21
VRdu	kN	880,96

5.3.5 Proiectarea ancorelor

În lucrarea prezentă, pentru a defini o metodă de proiectare pentru fundația ancorei, a fost luată în considerare metoda propusă de Bustamante și Doix (1985). Rezistența laterală S este determinată prin:

$$S = \pi \cdot ds \cdot Ls \cdot s$$

unde ds este diametrul echivalent al fundației ancorei, Ls este lungimea zonei injectate, și s este rezistența tangențială la interfața dintre zona injectată și solul înconjurător. În ecuațiile anterioare s-a asumat $ds = \alpha \cdot d$, unde d este diametrul perforației și α este un coeficient de creștere. Valorile rezistenței tangențiale pe suprafața unitară s corespund interfeței dintre zona injectată și sol depind atât de natura și caracteristicile solului cât și de tehnologia utilizată și pot fi ușor evaluate prin diagramele corespunzătoare raportate de Bustamante și Doix (1985).

REHABILITATION OF THE RAILWAY LINE BRASOV – SIMERIA, COMPONENT PART OF IV PAN-EUROPEAN CORRIDOR FOR THE TRAINS CIRCULATION WITH MAXIMUM SPEED OF 160 KM/H.

Secțiunea 1

Parametru	Simbol	U.m.	Nivel IV	Nivel III	Nivel II	Nivel I
			-12 m	-8 m	-4 m	-0,5 m
Rezistența caracteristică la rupere prin întindere	f _{ptk}	N/mm	1860	1860	1860	1860
Limita de curgere la 0.1 % elongație	f _{p1k}	N/mm	1670	1670	1670	1670
Număr de toroane din sârmă	n	-	6	6	6	6
Suprafața unitară a toronului din sârmă	A _t	mm ²	140	140	140	140
Suprafața totală a toroanelor din sârmă	A	mm ²	840	840	840	840
Diametrul găurii de foraj	D _p	m	0,2	0,2	0,2	0,2
Unghiul	θ	°	22,5	22,5	22,5	22,5
Coeficientul lui Bustamante și Doix	α		1,2	1,2	1,2	1,2
Rezistență tangențială pe suprafață unitară (q _s)	q _s	kPa	130	130	130	130
Distanțarea ancorelor	s	m	1,3	1,3	1,3	1,3
Sarcina care acționează pe ancoră (combinația STR)	T _k	kN	695	778	454	313
Sarcina care acționează pe ancoră (combinația GEO)	T _k	kN	553	613	350	227
Lungimea zonei injectate	L _{ck}	m	9,8	10,9	6,4	4,4
Înălțimea zidului sprijinit pe piloni	h _{pw}	m	28,0	28,0	28,0	28,0
Altitudinea ancorei	h _a	m	12,0	8,0	4,0	0,5
Lungimea liberă	L _f	m	9	10,8	13,0	14,9
Lungimea totală a ancorei	L _t	m	18,4	21,8	19,4	19,3
Tensiunea inițială a ancorei	T _i	KN	390	390	195	195
Rezistența caracteristică de rupere la întindere a unei singure ancore	R _k	kN	1562	1562	1562	1562
Rezistența extremă de rupere la întindere a unei singure ancore	R _d	kN	1420	1420	1420	1420

REHABILITATION OF THE RAILWAY LINE BRASOV – SIMERIA, COMPONENT PART OF IV PAN-EUROPEAN CORRIDOR FOR THE TRAINS CIRCULATION WITH MAXIMUM SPEED OF 160 KM/H.

Secțiunea 2

Parametru	Simbol	U.m.	Nivel III	Nivel II	Nivel I
			-8 m	-4 m	-0,5 m
Rezistența caracteristică la rupere prin întindere	f _{ptk}	N/mm	1860	1860	1860
Limita de curgere la 0.1 % elongație	f _{p1k}	N/mm	1670	1670	1670
Număr de toroane din sârmă	n	-	6	6	6
Suprafața unitară a toronului din sârmă	A _t	mm ²	140	140	140
Suprafața totală a toroanelor din sârmă	A	mm ²	840	840	840
Diametrul găurii de foraj	D _p	m	0,2	0,2	0,2
Unghiul	θ	°	22,5	22,5	22,5
Coeficientul lui Bustamante și Doix	α		1,2	1,2	1,2
Rezistență tangențială pe suprafață unitară (q _s)	q _s	kPa	130	130	130
Distanțarea ancorelor	s	m	1,3	1,3	1,3
Sarcina care acționează pe ancoră (combinația STR)	T _k	kN	606	434	338
Sarcina care acționează pe ancoră (combinația GEO)	T _k	kN	464	300	240
Lungimea zonei injectate	L _{ck}	m	8,5	6,1	4,7
Înălțimea zidului sprijinit pe piloni	h _{pw}	m	25,0	25,0	25,0
Altitudinea ancorei	h _a	m	8,0	4,0	0,5
Lungimea liberă	L _f	m	9,2	11,4	13,3
Lungimea totală a ancorei	L _t	m	17,7	17,5	18,0
Tensiunea inițială a ancorei	T _i	KN	390	195	195
Rezistența caracteristică de rupere la întindere a unei singure ancore	R _k	kN	1562	1562	1562
Rezistența extremă de rupere la întindere a unei singure ancore	R _d	kN	1420	1420	1420

REHABILITATION OF THE RAILWAY LINE BRASOV – SIMERIA, COMPONENT PART OF IV PAN-EUROPEAN CORRIDOR FOR THE TRAINS CIRCULATION WITH MAXIMUM SPEED OF 160 KM/H.

Secțiunea 3

Parametru	Simbol	U.m.	Nivel II	Nivel I
			-4 m	-0,5 m
Rezistența caracteristică la rupere prin întindere	f _{ptk}	N/mm ²	1860	1860
Limita de curgere la 0.1 % elongație	f _{p1k}	N/mm ²	1670	1670
Număr de toroane din sârmă	n	-	6	6
Suprafața unitară a toronului din sârmă	A _t	mm ²	140	140
Suprafața totală a toroanelor din sârmă	A	mm ²	840	840
Diametrul găurii de foraj	D _p	m	0,2	0,2
Unghiul	θ	°	22,5	22,5
Coeficientul lui Bustamante și Doix	α		1,2	1,2
Rezistență tangențială pe suprafață unitară (q _s)	q _s	kPa	130	130
Distanțarea ancorelor	s	m	1,3	1,3
Sarcina care acționează pe ancoră (combinația STR)	T _k	kN	393	357
Sarcina care acționează pe ancoră (combinația GEO)	T _k	kN	330	247
Lungimea zonei injectate	L _{ck}	m	5,5	5,0
Înălțimea zidului sprijinit pe piloni	h _{pw}	m	25,0	25,0
Altitudinea ancorei	h _a	m	4,0	0,5
Lungimea liberă	L _f	m	11,4	13,3
Lungimea totală a ancorei	L _t	m	16,9	18,3
Tensiunea inițială a ancorei	T _i	KN	195	195
Rezistența caracteristică de rupere la întindere a unei singure ancore	R _k	kN	1562	1562
Rezistența extremă de rupere la întindere a unei singure ancore	R _d	kN	1420	1420

6 CRITERIILE DE PROIECTARE ȘI ANALIZA STRUCTURILOR PERMANENTE

6.1 Descrierea structurilor permanente pentru intrarea tunelului

Structurile permanente pentru intrarea tunelului de pe latura Ormenis sunt descrise după cum urmează:

	LATURA ORMENIS	
	CANAL	TUNEL ARTIFICIAL
	L (m)	L (m)
LINIA 1 ORMENIS	15,00	31.72
LINIA 2 ORMENIS	15,00	31.72

Structurile permanente sunt construite după executarea unei excavații sprijinită de zidul de reazem pe piloni și apoi acestea vor fi acoperite de excavarea solului.

6.2 Criteriile de proiectare

Tunelul artificial a fost verificat în secțiunea cu solul maxim de acoperire. Rezultatele acestei analize au fost extinse la portalul de intrare a tunelului.

Calculul a fost făcut cu programul FEM versiunea Nelineară 14.2 SAP 2000, distribuită de Computers and Structures, Inc., iar verificările au fost efectuate la ULS și SLS.

În continuare, sunt explicate criteriile pentru determinarea cazurilor de sarcini și verificarea așteptată de la Eurocod 2.

6.3 Cazurile de sarcină

6.3.1. Sarcini verticale

Sarcinile verticale luate în considerare în analize sunt:

- Greutatea proprie a căptușelii;
- Solul acoperitor.

Greutatea volumetrică a betonului, conform EN 1991-1-1, se presupune egală cu 24 kN/m³ și 25 kN/m³ pentru beton nearamat și respectiv armat.

Sarcina verticală datorată solului acoperitor este calculată prin ecuația următoare:

$$P_v = \gamma H$$

unde:

γ = greutatea specifică totală;

H = adâncimea solului acoperitor (raportată la coronament).

6.3.2. Sarcini orizontale

Sarcinile orizontale P_h , care acționează pe termen lung și sunt variabile în funcție de adâncimi, sunt estimate după cum urmează:

$$P_h = K P_v + K \gamma z$$

unde:

g = greutatea volumetrică;

K = coeficientul de presiune a pământului;

z = înălțimea totală a tunelului.

Dacă tunelul se confruntă cu un strat de apă, se va lua în considerare presiunea hidrostatică prin evaluarea presiunilor efective ale solului, în plus față de cea hidrostatică

6.3.3. Sarcini seismice

Efectele seismice asupra tunelului căptușit artificial sunt introduce în calcul prin analiza statică echivalentă:

- $a_g = 0,16g$
- categoria de sol: C
- $S = 1,50$; $ST = 1,0$
- Coeficientul seismic orizontal (k_h) este
$$k_h = S \times ST \times a_g / g = 1,50 \times 1,0 \times 0,16 = 0,24$$

Punctul de aplicare trebuie să fie luat la jumătatea laturii verticale a pilonului stâng și drept. În plus față de împingerea terenului, tunelul este supusă la forțele de inerție:

$$F_i = k_h \times W$$

unde W sunt greutatea cu sarcinile lor uzate și permanente.

Aceste sarcini sunt aplicate pe o direcție sau alta în funcție de situația solicitărilor pentru mai multă structură.

6.3.4. Presiunile seismice ale pământului (Mononobe–Okabe)

Aceasta a fost o extindere a metodei Coulomb în cazul static pentru determinarea presiunilor pământului luând în considerare echilibrul prisme triunghiulare de alunecare. Metoda este acum cunoscută în mod obișnuit ca și metoda Mononobe– Okabe. Pentru a calcula presiunea activă și pasivă a pământului prin forțele pseudostatice precum forțele seismice ce acționează în solul de umplutură fără coeziune, în analiză a fost asumată suprafața planară de rupere. Presiunea seismică activă și pasivă a pământului (P_{ae} , P_{pe}) poate fi calculată prin ecuația Mononobe–Okabe după cum urmează:

$$P_{ae}, P_{pe} = \frac{1}{2} \gamma H^2 (1 - kv) K$$

Presiunea activă a pământului:

REHABILITATION OF THE RAILWAY LINE BRASOV – SIMERIA, COMPONENT PART OF IV PAN-EUROPEAN CORRIDOR FOR THE TRAINS CIRCULATION WITH MAXIMUM SPEED OF 160 KM/H.

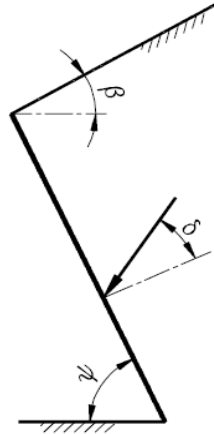

$$\beta \leq \phi - \theta: \quad K = \frac{\text{sen}^2 (\psi + \phi - \theta)}{\cos \theta \text{sen}^2 \psi \text{sen} (\psi - \theta - \delta) \left[1 + \sqrt{\frac{\text{sen} (\phi + \delta) \text{sen} (\phi - \beta - \theta)}{\text{sen} (\psi - \theta - \delta) \text{sen} (\psi + \beta)}} \right]^2}$$

$$\beta > \phi - \theta: \quad K = \frac{\text{sen}^2 (\psi + \phi - \theta)}{\cos \theta \text{sen}^2 \psi \text{sen} (\psi - \theta - \delta)}$$

Presiunea pasivă a pământului:

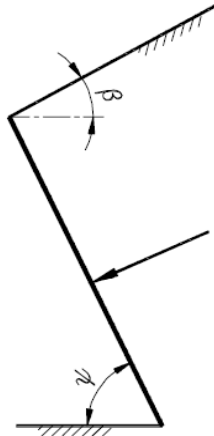

$$K = \frac{\text{sen}^2 (\psi + \theta - \phi)}{\cos \theta \text{sen}^2 \psi \text{sen} (\psi + \theta) \left[1 - \sqrt{\frac{\text{sen} \phi \text{sen} (\phi + \beta - \theta)}{\text{sen} (\psi + \beta) \text{sen} (\psi + \theta)}} \right]^2}$$

$$\tan \vartheta = \frac{k_h}{1 \mp k_v}$$

REHABILITATION OF THE RAILWAY LINE BRASOV – SIMERIA, COMPONENT PART OF IV PAN-EUROPEAN CORRIDOR FOR THE TRAINS CIRCULATION WITH MAXIMUM SPEED OF 160 KM/H.

unde

γ = greutatea specifică a solului;

H = înălțimea verticală a zidului;

K = coeficientul de presiune seismică activă și pasivă a pământului;

ϕ = unghiul de frecare a solului;

δ = unghiul de frecare a zidului;

β = înclinarea zidului față de verticală;

i = înclinarea terenului față de orizontală;

kh = coeficientul de accelerație seismică în direcție orizontală; kv = coeficientul de accelerație seismică în direcție verticală.

6.4. Caracterizarea materialului și criteriul de verificare

6.4.1. Starea limită extremă

Valorile de proiectare ale cazurilor de sarcină se găsesc prin aplicarea coeficientului prezentat în tabelul următor, în conformitate cu EN 1990:2002 (E): Baza proiectării structurale.

Table A1.2(B) - Design values of actions (STR/GEO) (Set B)

Persistent and transient design situations	Permanent actions		Leading variable action	Accompanying variable actions (*)		Persistent and transient design situations	Permanent actions		Leading variable action (*)	Accompanying variable actions (*)	
	Unfavourable	Favourable		Main (if any)	Others		Unfavourable	Favourable		Action	Main
(Eq. 6.10)	$\gamma_{G,sup} G_{k,sup}$	$\gamma_{G,inf} G_{k,inf}$	$\gamma_{Q,1} Q_{k,1}$		$\gamma_{Q,i} \psi_{0,i} Q_{k,i}$	(Eq. 6.10a)	$\gamma_{G,sup} G_{k,sup}$	$\gamma_{G,inf} G_{k,inf}$		$\gamma_{Q,1} \psi_{0,1} Q_{k,1}$	$\gamma_{Q,i} \psi_{0,i} Q_{k,i}$
						(Eq. 6.10b)	$\xi \gamma_{G,sup} G_{k,sup}$	$\gamma_{G,inf} G_{k,inf}$	$\gamma_{Q,1} Q_{k,1}$		$\gamma_{Q,i} \psi_{0,i} Q_{k,i}$

(*) Variable actions are those considered in Table A1.1

NOTE 1 The choice between 6.10, or 6.10a and 6.10b will be in the National annex. In case of 6.10a and 6.10b, the National annex may in addition modify 6.10a to include permanent actions only.

NOTE 2 The γ and ξ values may be set by the National annex. The following values for γ and ξ are recommended when using expressions 6.10, or 6.10a and 6.10b.
 $\gamma_{G,sup} = 1,35$
 $\gamma_{G,inf} = 1,00$
 $\gamma_{Q,1} = 1,50$ where unfavourable (0 where favourable)
 $\gamma_{Q,i} = 1,50$ where unfavourable (0 where favourable)
 $\xi = 0,85$ (so that $\xi \gamma_{G,sup} = 0,85 \times 1,35 \cong 1,15$).
 See also EN 1991 to EN 1999 for γ values to be used for imposed deformations.

NOTE 3 The characteristic values of all permanent actions from one source are multiplied by $\gamma_{G,sup}$ if the total resulting action effect is unfavourable and $\gamma_{G,inf}$ if the total resulting action effect is favourable. For example, all actions originating from the self weight of the structure may be considered as coming from one source ; this also applies if different materials are involved.

NOTE 4 For particular verifications, the values for γ_G and γ_Q may be subdivided into γ_g and γ_q and the model uncertainty factor $\gamma_{\delta,i}$. A value of $\gamma_{\delta,i}$ in the range 1,05 to 1,15 can be used in most common cases and can be modified in the National annex.

Verificările sunt efectuate pentru repetarea forțelor axiale de încovoiere (domeniul M-N) și a forțelor de forfecare. Diagrama parabolă-rectangulară de tensiune-deformație se presupune că descrie comportarea betonului ($\epsilon_2 = 0,2\%$ și $\epsilon_{cu} = 0,35\%$), plastică perfect elastică pentru armăturile din oțel ($\epsilon_{yd} = 0,186\%$ și $\epsilon_{su} = 1\%$). Rezistența betonului la tensiune a fost asumată ca fiind egală cu zero.

6.4.2. Starea limită de deservire

Acțiunile de proiectare pentru starea limită de deservire sunt obținute aplicând coeficientul unitar la cazurile de sarcină persistentă. Pentru cazurile de sarcină accidentală sunt incluși coeficienții ψ_i , în conformitate cu Eurocod, pentru combinațiile frecvente și cvasi-permanente.

Verificarea diferitelor stări limită de deservire este efectuată ca limitare a tensiunilor și a lățimii crăpăturilor.

În conformitate cu EN 1992-1-1, conform condițiilor de sarcini de serviciu, este cerută limitarea eforturilor pentru:

- Eforturile de compresie în beton;
- Eforturile de întindere în oțel.

Eforturile de compresie în beton trebuie să fie mai mici de $k_2 f_{ck}$ ($k_2=0,45$), în timp ce tensiunea în barele de oțel poate fi $k_3 f_{yk}$ ($k_3=0,8$).

Starea limită de verificare a crăpăturilor presupune că trebuie să fie respectată următoarea verificare:

$$w_k \leq w_{lim}$$

Unde w_k denotă lățimea caracteristică a crăpăturii calculată așa cum se explică în EN 1992-1-1 paragraf 7.3.4 și fiind egală cu 0,3 mm.

Verificarea este efectuată asumând următorii parametri:

- $k_1=0,4$
- $k_2=0,8$
- $k_3=0,5$
- $f_{ctm}=3,2$ MPa

6.5. Metoda de calcul

A fost asumată metoda de reacție hiperstatică pentru a stabili acțiunile interne în căptușeala de beton prin modelul numeric de element finit monodimensional. Modelul a fost creat pentru a reprezenta o adâncime unitară (1,0 m) de tunel, precizând geometria secțiunii la elementele de grindă. Pentru a simula corect repetarea de structură-sol, pentru fiecare nod al modelului de element finit, se precizează suportii radiali de rigidizare. Valoarea de rigiditate se determină din modulul K de reacție a solului.

La radierul tunelului, K a fost calculat prin formula lui Galerkin pentru suprafață curbilinie după cum urmează:

$$K = E / [Req \times (1+\nu)] [F/L^3]$$

cu:

E = modulul de elasticitate a solului;

ν = coeficientul Poisson al solului;

Req = raza echivalentă de curbură a tunelului.

La piloni, K a fost calculat cu formula Bussinesque pentru suprafață liniară după cum urmează:

$$K = E / [(1+\nu^2) \times B \times Cd] [F/L^3]$$

E = modulul de elasticitate a solului;

ν = coeficientul Poisson al solului;

B = lățimea elementului structural.

Cd= coeficient de formă

6.6. Cazuri analizate

În secțiunea tipică există o sarcină verticală uniformă și sarcini orizontale simetrice, toate definite ca permanente în conformitate cu Eurocod. Comportarea mecanică a solului este reprezentată prin suportii radiali, activi numai la compresie.

Tabelele următoare prezintă valorile sarcinilor și parametrilor folosiți în calcul:

USL			
Descriere	Simbol	U.M.	Valoare
Greutatea specifică a solului	γ	kN/m ³	21
Raza tunelului	R	m	5,1
Modulul de elasticitate a solului	Ed	kN/m ²	45000
Formula de rigiditate a lui Galerkin	Ka.r.	kN/m ³	6787
Formula de rigiditate a lui Boussinesque	Kcal	kN/m ³	19780
Presiunea activă a pământului (Caquot și Kerisel)	ka	-	0,44
Accelerația	ag	-	0,16
Coeficient care ia în considerare aspectele stratigrafice și topografice	S	-	1,50
Coeficient seismic orizontal	kh	-	0,240
Coeficient seismic vertical	kv	-	0,120
Presiunea dinamică a pământului (Mononobe și Okabe)	kas	-	0,60

REHABILITATION OF THE RAILWAY LINE BRASOV – SIMERIA, COMPONENT PART OF IV PAN-EUROPEAN CORRIDOR FOR THE TRAINS CIRCULATION WITH MAXIMUM SPEED OF 160 KM/H.

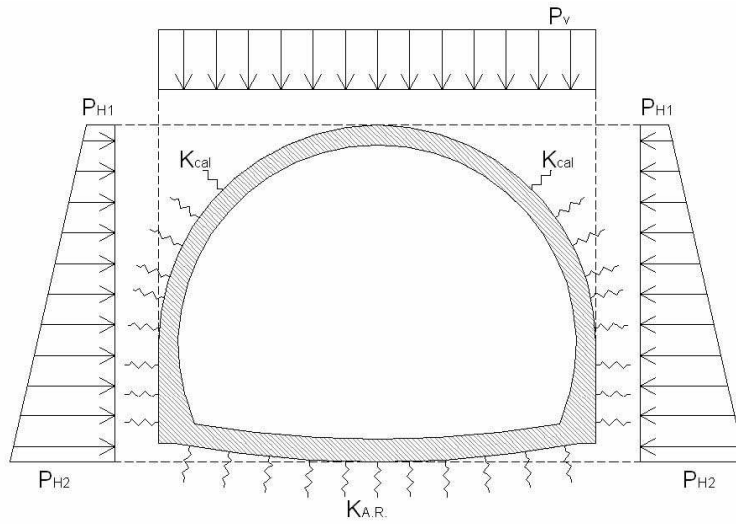

P_v	P_{vw}	$Ph1$	$Ph2$	$Phw1$	$phw2$	ΔS
kPa	kPa	kPa	kPa	kPa	kPa	kPa
63	20	27,72	114,576	20	94	24

6.7. Rezultatele analizei

A fost realizat un model de element finit pentru determinarea momentului de încovoiere și forța axială și de forfecare care acționează în diferite secțiuni ale studiului de caz. Modelul a fost creat în conformitate cu geometria secțiunii cu elemente de grindă. Condițiile de graniță au fost simulate cu suporturi de rigidizare radială așa cum s-a explicat în paragrafele anterioare. Rezultatele analizei de element finit sunt expuse pentru fiecare stare limită luată în considerare (extremă, seismică și de deservire). Rezultatele se referă la cazul de sarcină a înfășurătorii care limitează forța și momentul. În următoarele paragrafe sunt ilustrate cazurile cu rezultatul analizei și verificările pentru fiecare caz. Verificările sunt făcute în secțiunile indicate în figura de mai jos.

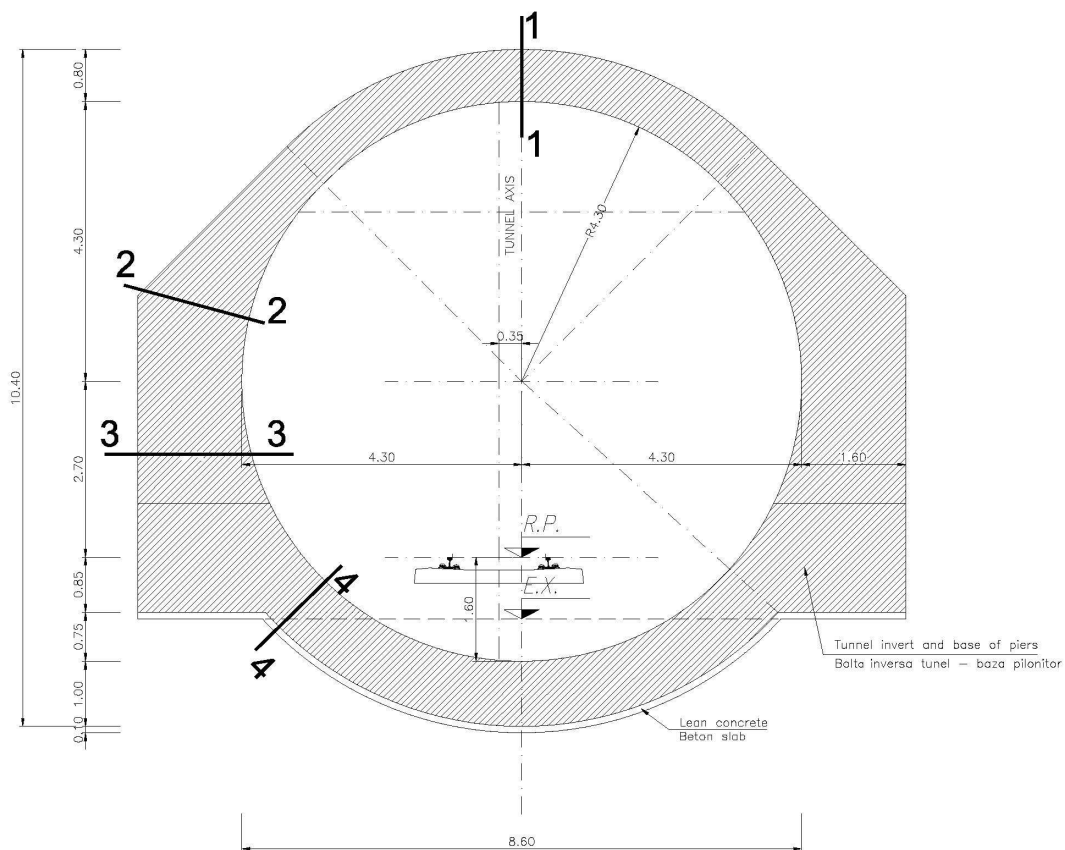

REHABILITATION OF THE RAILWAY LINE BRASOV – SIMERIA, COMPONENT PART OF IV PAN-EUROPEAN CORRIDOR FOR THE TRAINS CIRCULATION WITH MAXIMUM SPEED OF 160 KM/H.

STAREA LIMITĂ EXTREMĂ - STATICĂ

SAP2000

11/8/11 15:07:47

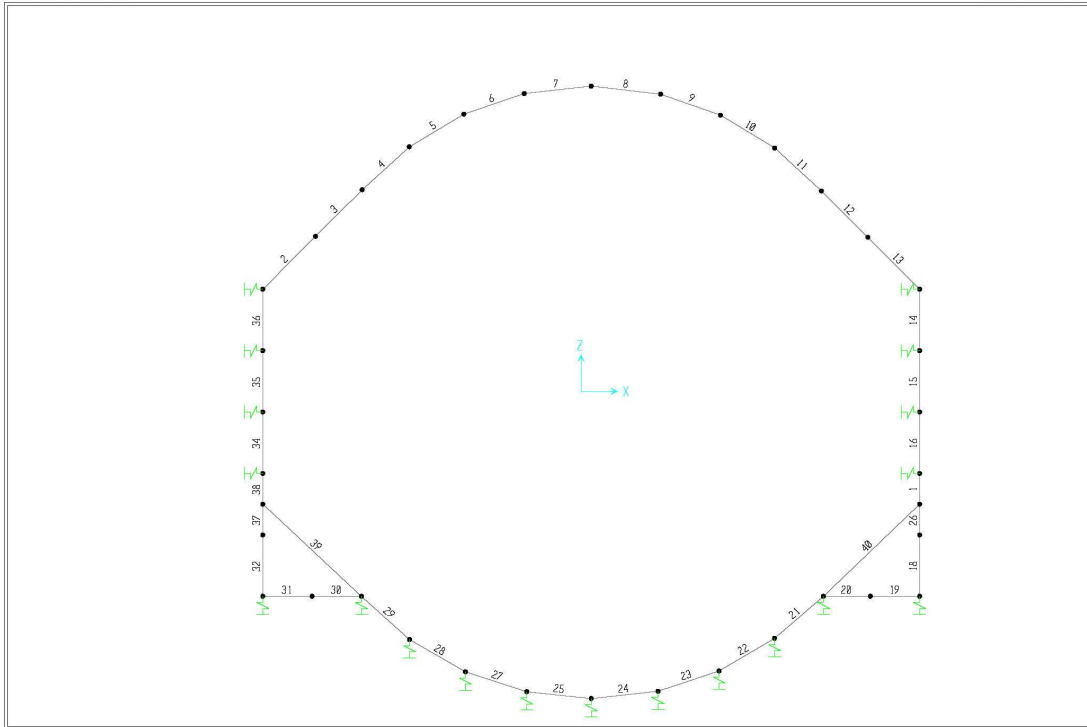

SAP2000 v14.2.2 - File:Ormenis Static - X-Z Plane @ Y=0 - KN, m, C Units

REHABILITATION OF THE RAILWAY LINE BRASOV – SIMERIA, COMPONENT PART OF IV PAN-EUROPEAN CORRIDOR FOR THE TRAINS CIRCULATION WITH MAXIMUM SPEED OF 160 KM/H.

SAP2000

11/8/11 15:08:44

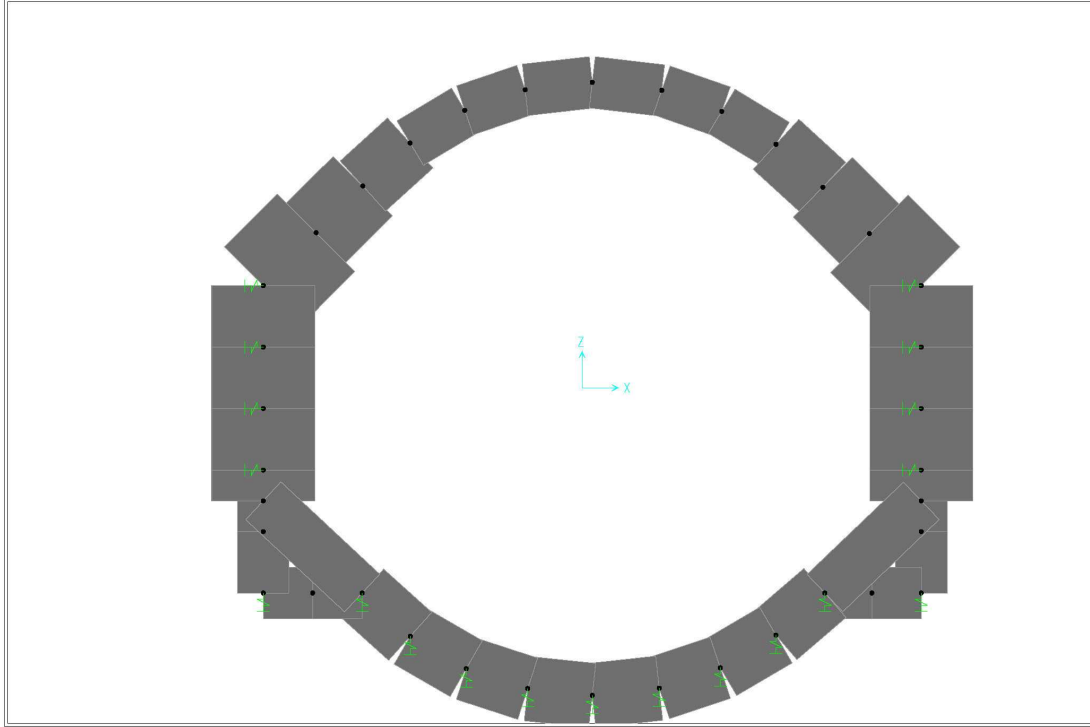

SAP2000 v14.2.2 - File:Ormenis Static - X-Z Plane @ Y=0 - KN, m, C Units

SAP2000

11/8/11 15:10:16

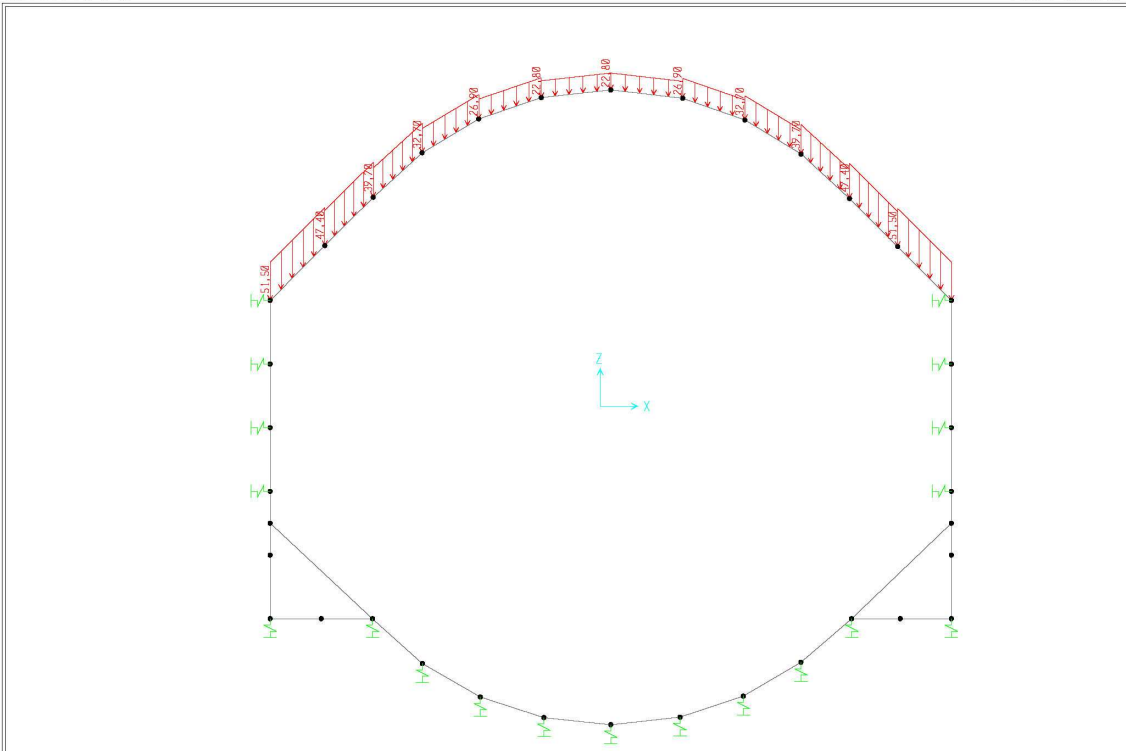

SAP2000 v14.2.2 - File:Ormenis Static - Frame Span Loads (EARTH) (As Defined) - KN, m, C Units

REHABILITATION OF THE RAILWAY LINE BRASOV – SIMERIA, COMPONENT PART OF IV PAN-EUROPEAN CORRIDOR FOR THE TRAINS CIRCULATION WITH MAXIMUM SPEED OF 160 KM/H.

SAP2000

11/8/11 15:11:32

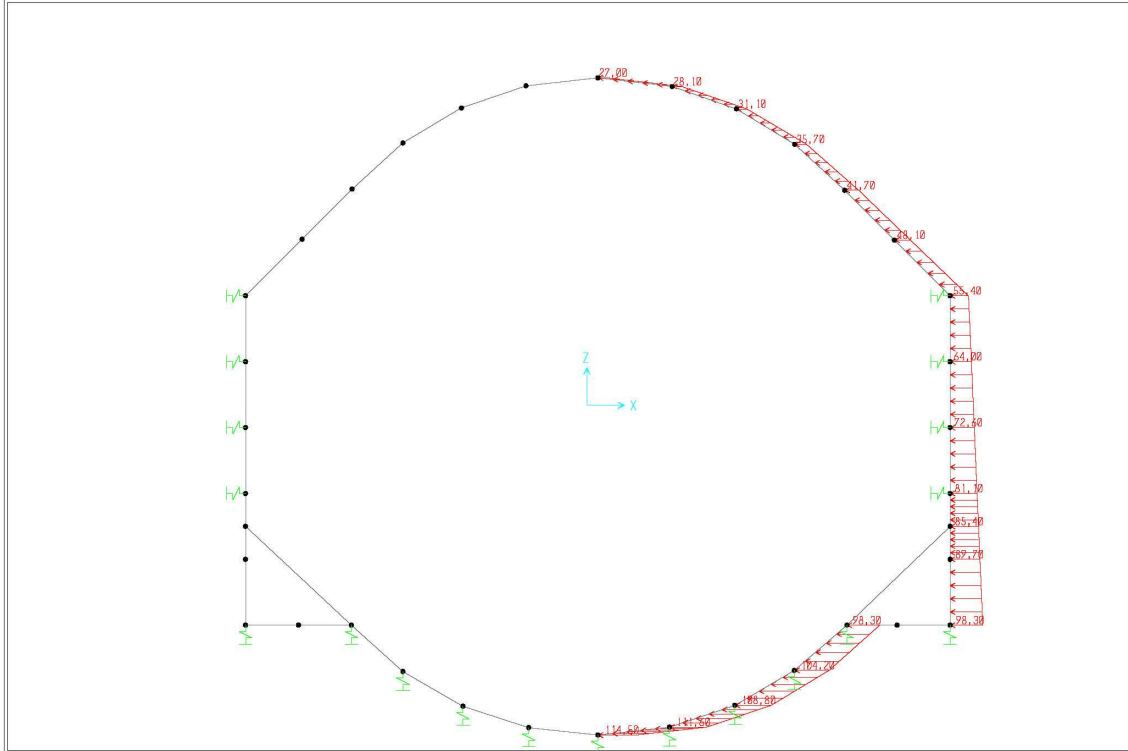

SAP2000 v14.2.2 - File:Ormenis Static - Frame Span Loads (EARTH_PRESSURED_X) (As Defined) - KN, m, C Units

SAP2000

11/8/11 15:12:27

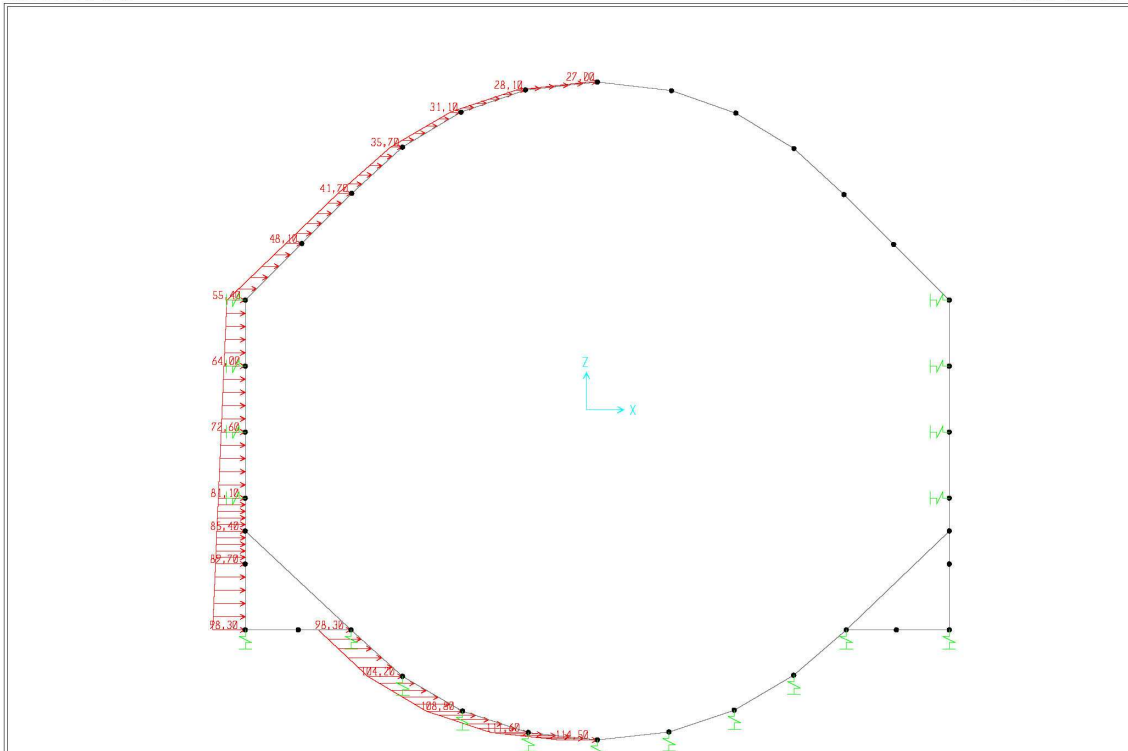

SAP2000 v14.2.2 - File:Ormenis Static - Frame Span Loads (EARTH_PRESSURED_X) (As Defined) - KN, m, C Units

REHABILITATION OF THE RAILWAY LINE BRASOV – SIMERIA, COMPONENT PART OF IV PAN-EUROPEAN CORRIDOR FOR THE TRAINS CIRCULATION WITH MAXIMUM SPEED OF 160 KM/H.

SAP2000

11/8/11 15:15:07

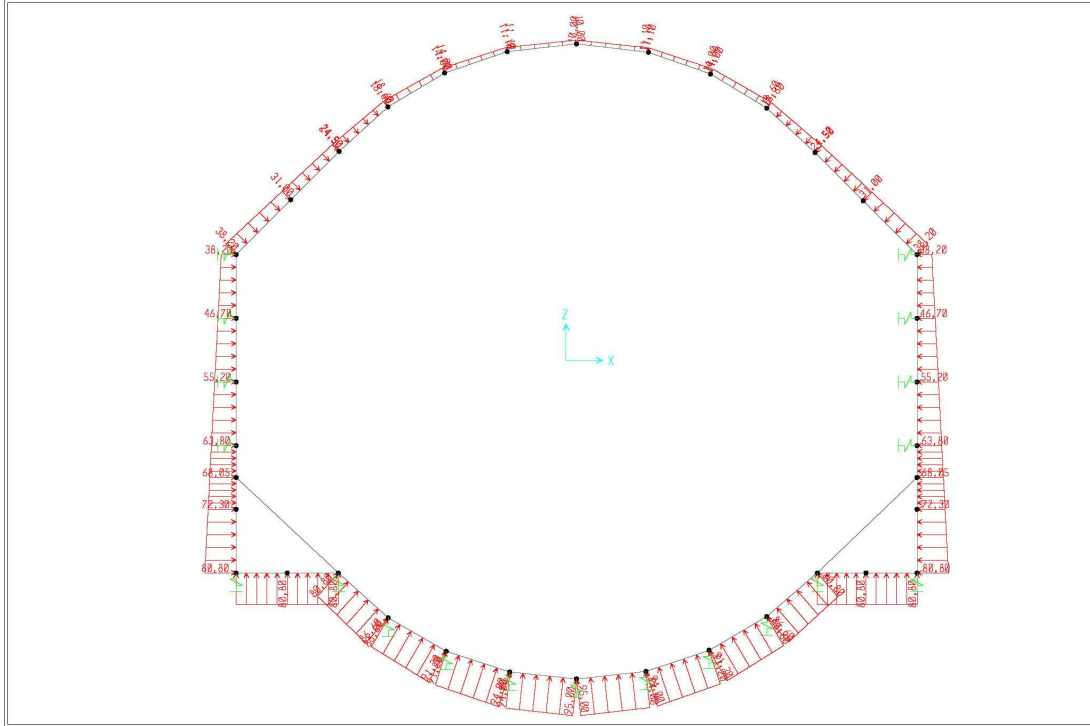

SAP2000 v14.2.2 - File:Ormenis Static - Frame Span Loads (HYDROSTATIC) (As Defined) - KN, m, C Units

SAP2000

11/8/11 15:35:16

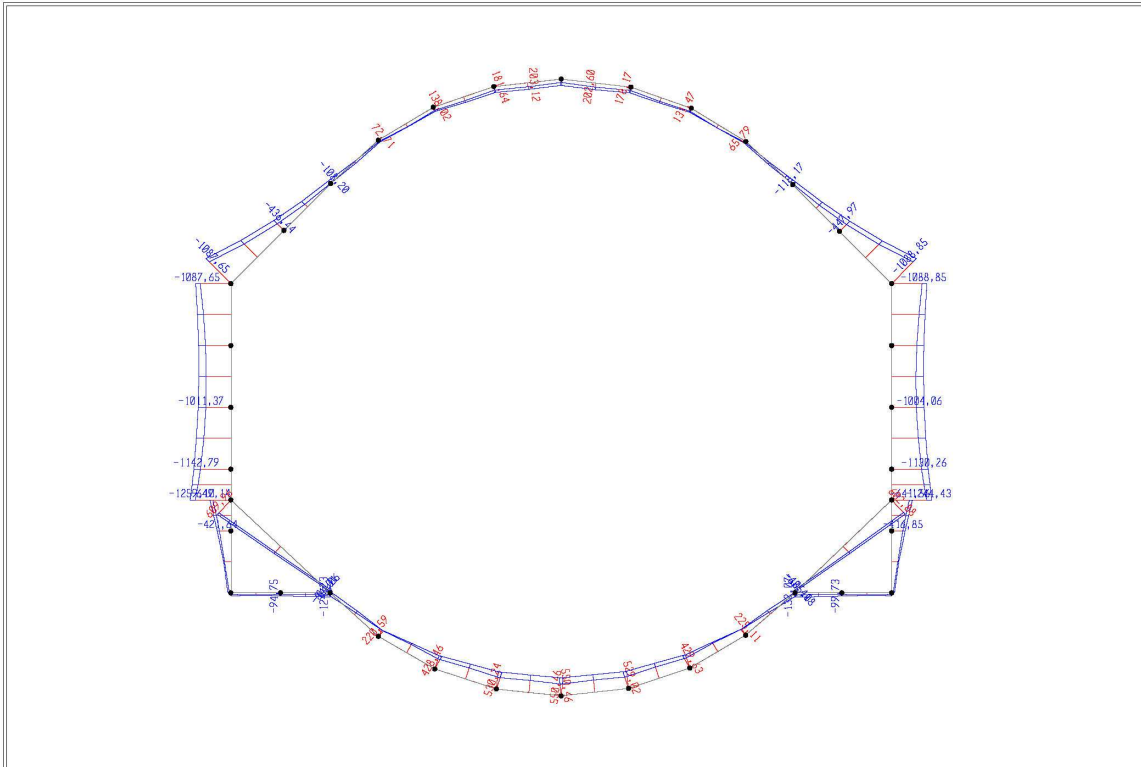

SAP2000 v14.2.2 - File:Ormenis Static - Moment 3-3 Diagram (ENVELOPE_ULS) - KN, m, C Units

REHABILITATION OF THE RAILWAY LINE BRASOV – SIMERIA, COMPONENT PART OF IV PAN-EUROPEAN CORRIDOR FOR THE TRAINS CIRCULATION WITH MAXIMUM SPEED OF 160 KM/H.

SAP2000

11/8/11 15:37:29

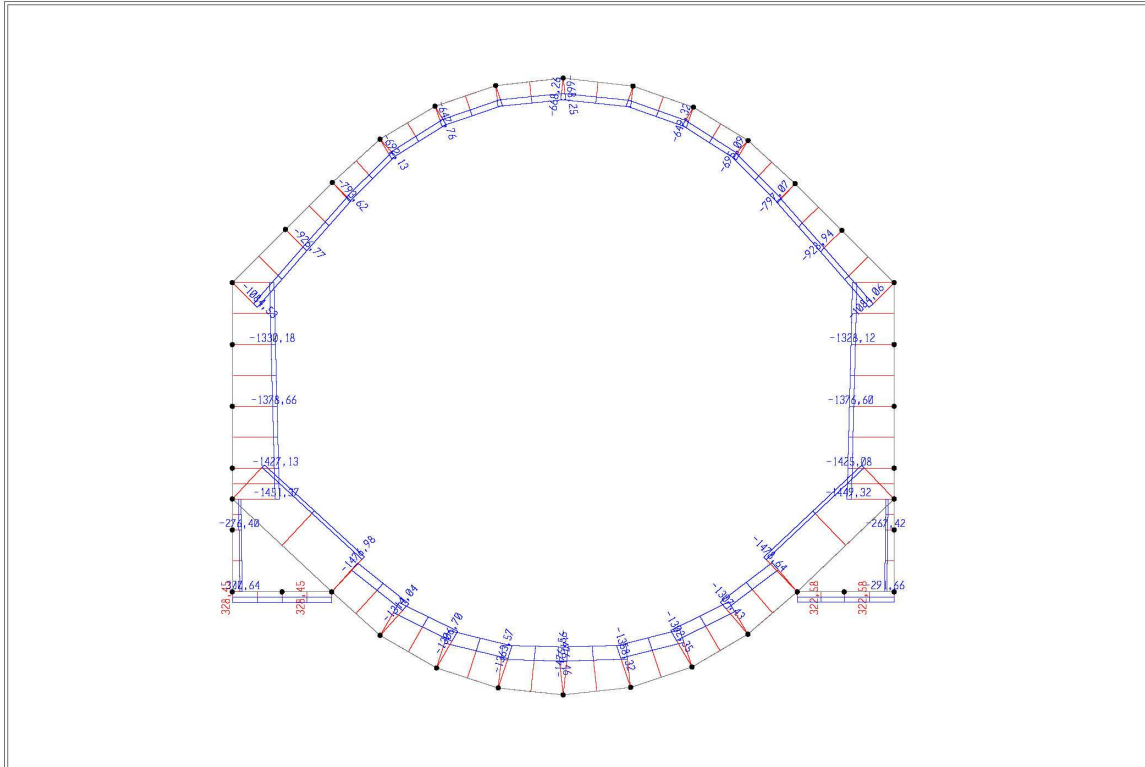

SAP2000 v14.2.2 - File:Ormenis Static - Axial Force Diagram (ENVELOPE_ULS) - KN, m, C Units

SAP2000

11/8/11 15:38:35

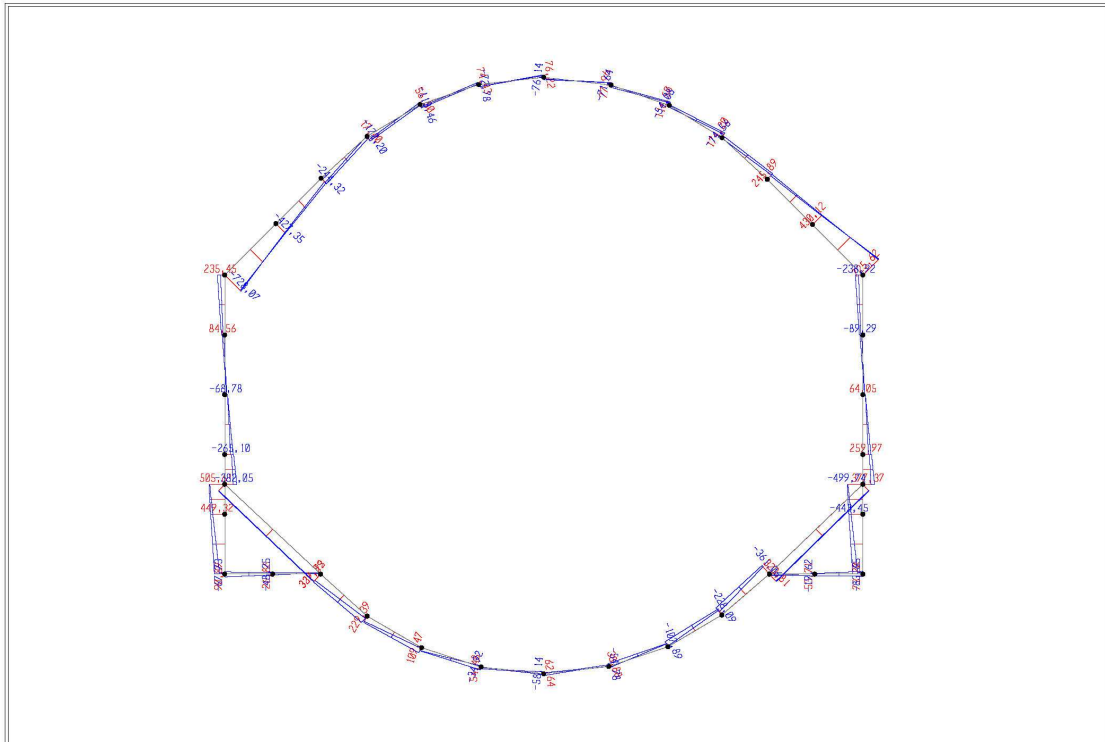

SAP2000 v14.2.2 - File:Ormenis Static - Shear Force 2-2 Diagram (ENVELOPE_ULS) - KN, m, C Units

REHABILITATION OF THE RAILWAY LINE BRASOV – SIMERIA, COMPONENT PART OF IV PAN-EUROPEAN CORRIDOR FOR THE TRAINS CIRCULATION WITH MAXIMUM SPEED OF 160 KM/H.

STAREA LIMITĂ EXTREMĂ - SEISMICĂ

SAP2000

11/8/11 15:16:32

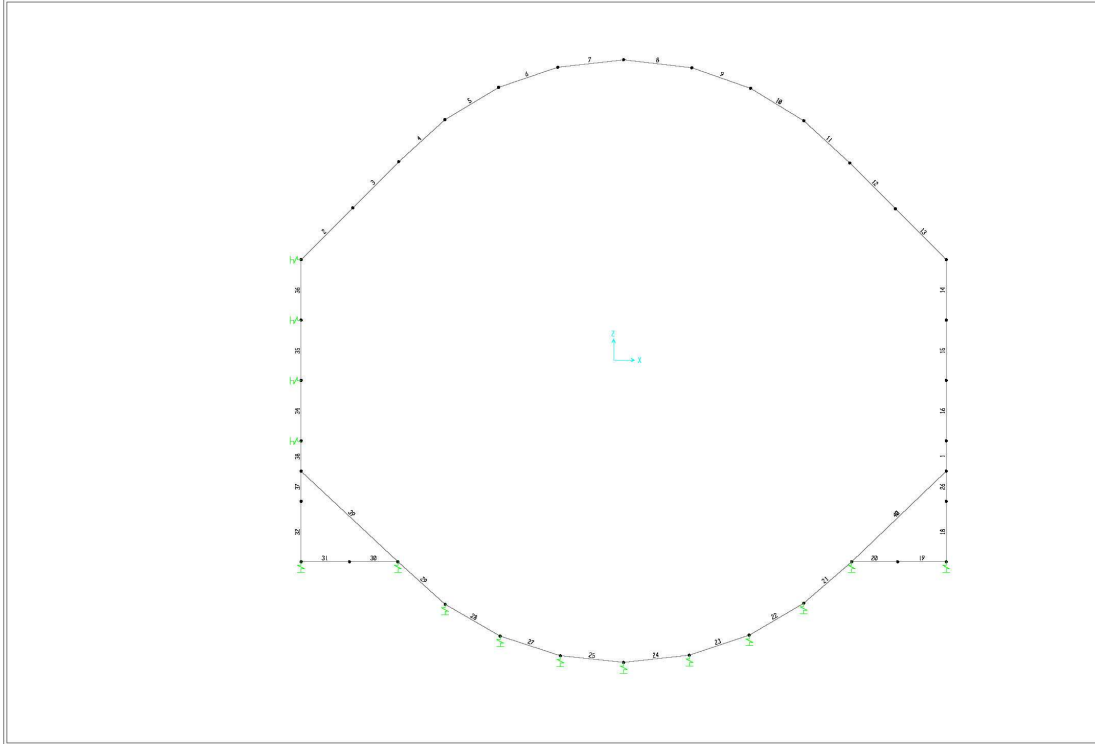

SAP2000 v14.2.2 - File:Ormenis Seismic - X-Z Plane @ Y=0 - KN, m, C Units

SAP2000

11/8/11 15:18:48

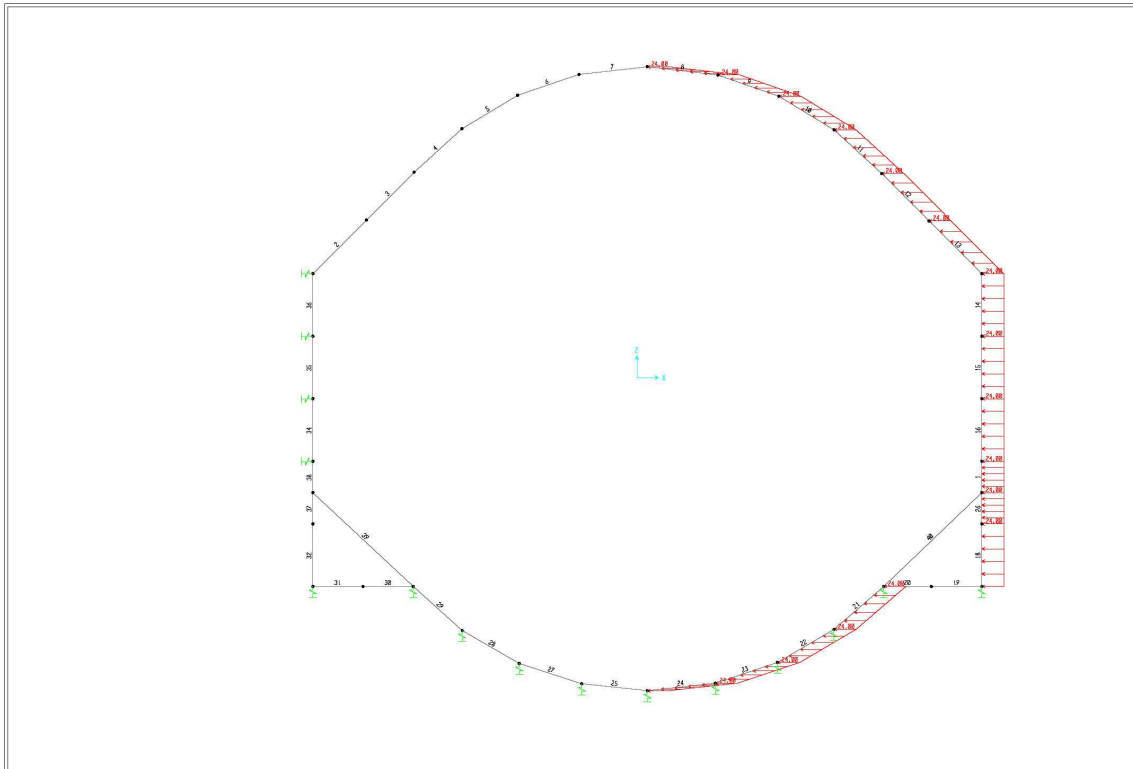

SAP2000 v14.2.2 - File:Ormenis Seismic - Frame Span Loads (DINAMIC EARTH PRESSURE) (As Defined) - KN, m, C Units

REHABILITATION OF THE RAILWAY LINE BRASOV – SIMERIA, COMPONENT PART OF IV PAN-EUROPEAN CORRIDOR FOR THE TRAINS CIRCULATION WITH MAXIMUM SPEED OF 160 KM/H.

SAP2000

11/8/11 15:25:45

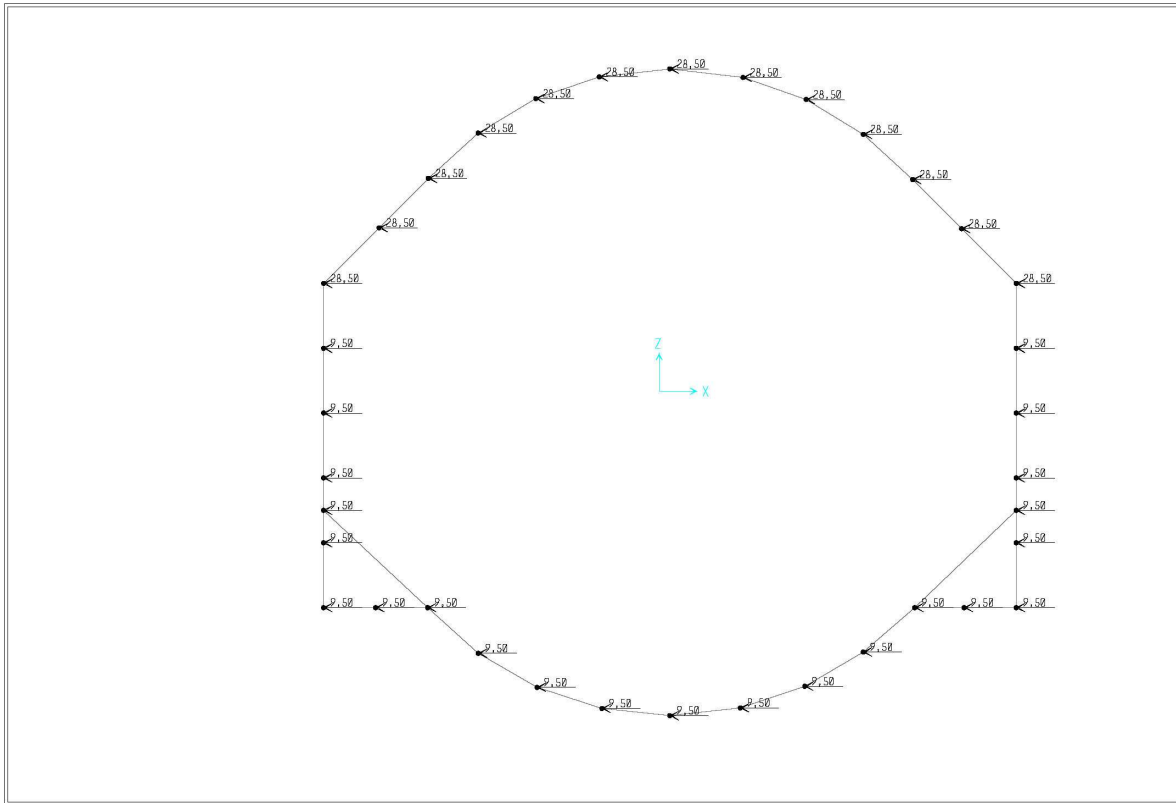

SAP2000 v14.2.2 - File:Ormenis Seismic - Joint Loads (INERTIA) (As Defined) - KN, m, C Units

SAP2000

11/8/11 15:43:27

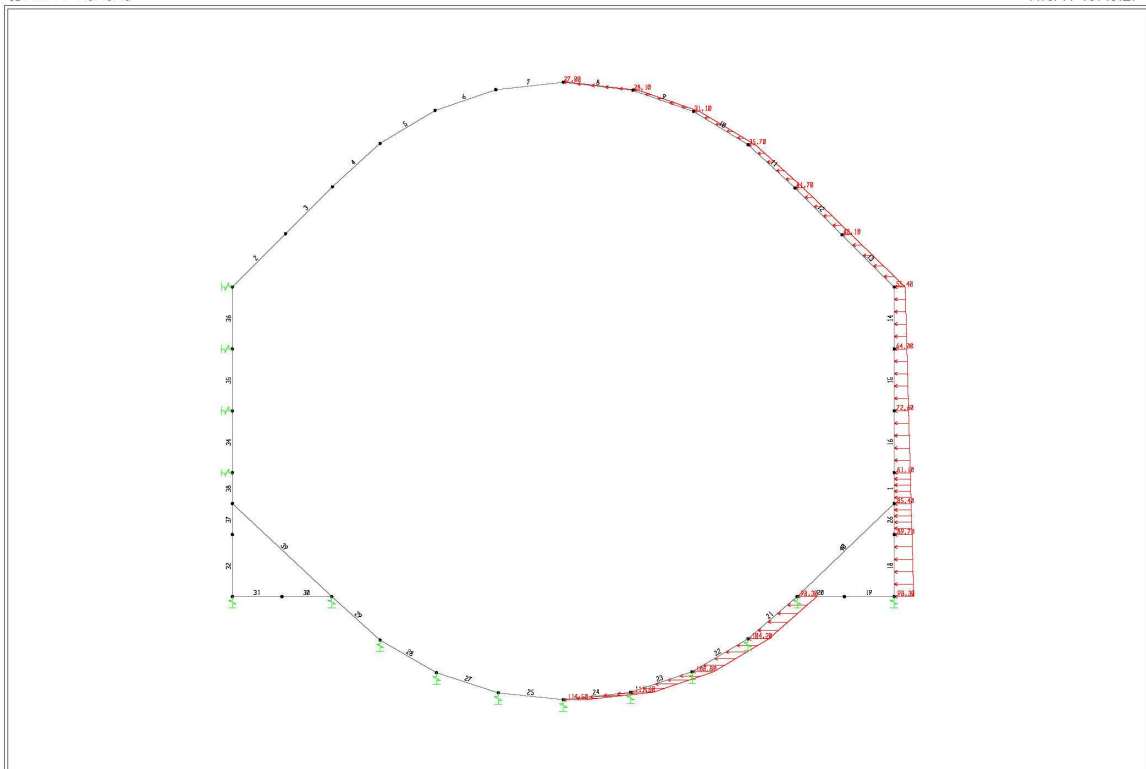

SAP2000 v14.2.2 - File:Ormenis Seismic - Frame Span Loads (EARTH_PRESSEDX) (As Defined) - KN, m, C Units

REHABILITATION OF THE RAILWAY LINE BRASOV – SIMERIA, COMPONENT PART OF IV PAN-EUROPEAN CORRIDOR FOR THE TRAINS CIRCULATION WITH MAXIMUM SPEED OF 160 KM/H.

SAP2000

11/8/11 15:44:33

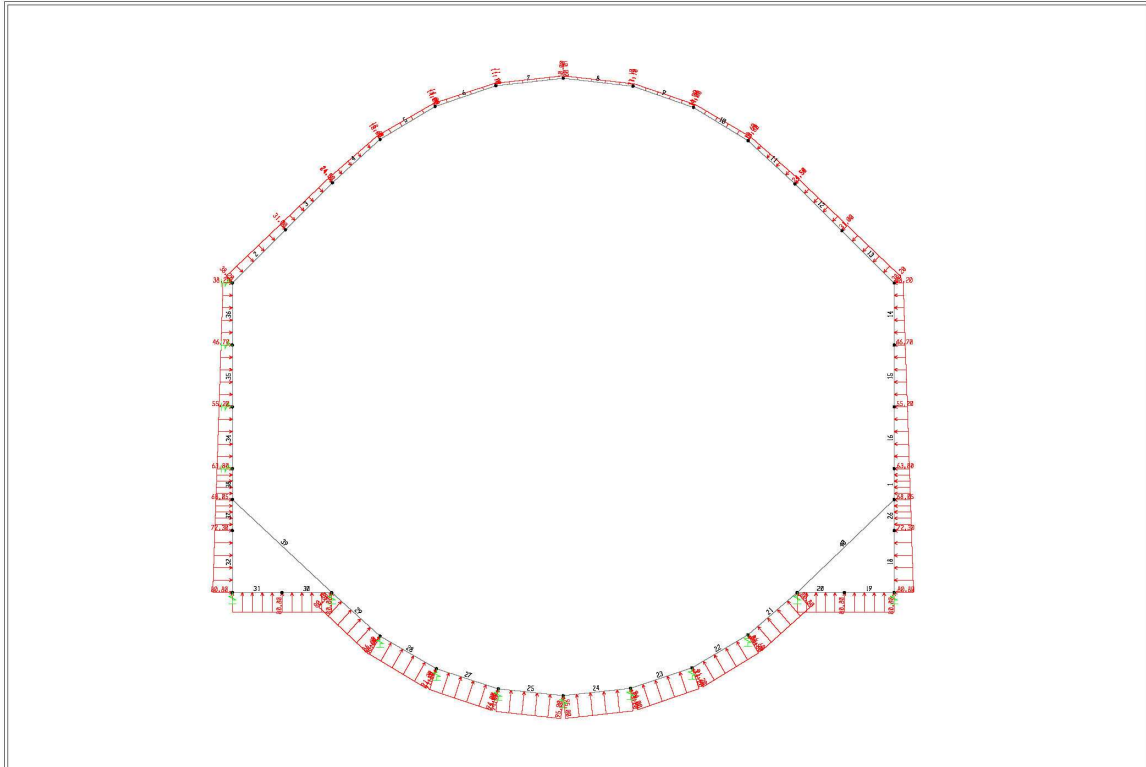

SAP2000 v14.2.2 - File:Ormenis Seismic - Frame Span Loads (HYDROSTATIC) (As Defined) - KN, m, C Units

SAP2000

11/8/11 15:45:25

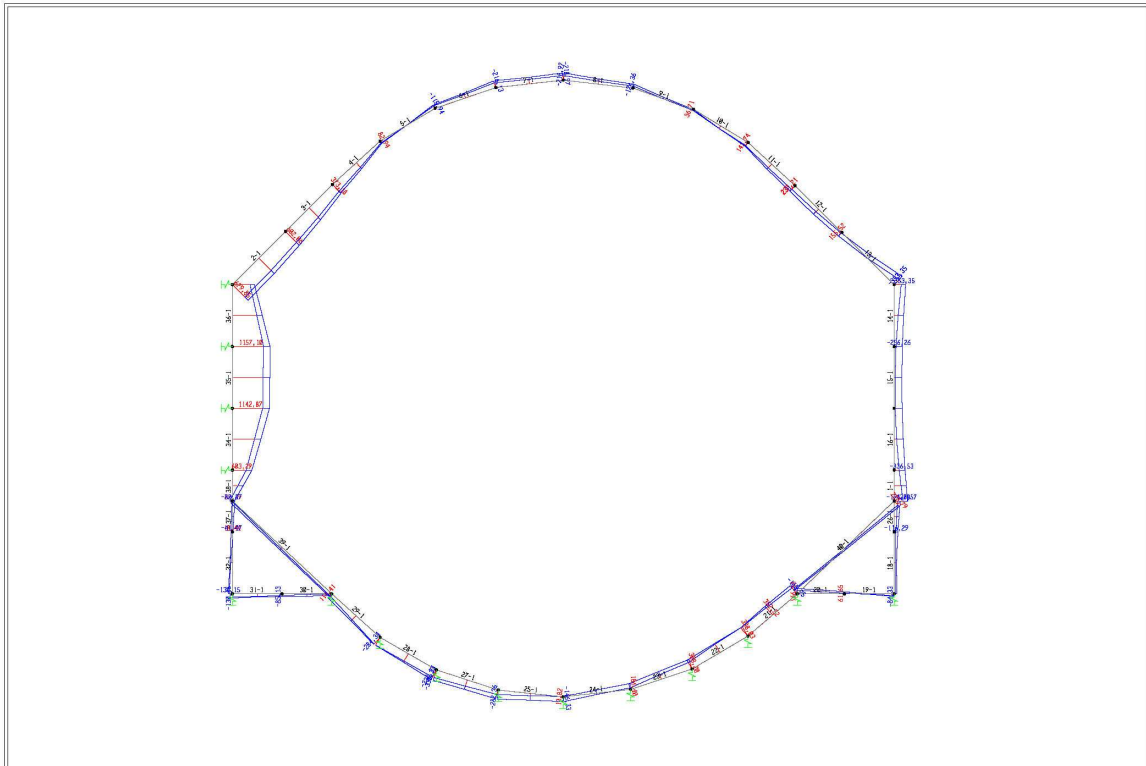

SAP2000 v14.2.2 - File:Ormenis Seismic - Moment 3-3 Diagram (ENVELOPE_ULS) - KN, m, C Units

REHABILITATION OF THE RAILWAY LINE BRASOV – SIMERIA, COMPONENT PART OF IV PAN-EUROPEAN CORRIDOR FOR THE TRAINS CIRCULATION WITH MAXIMUM SPEED OF 160 KM/H.

SAP2000

11/8/11 15:46:52

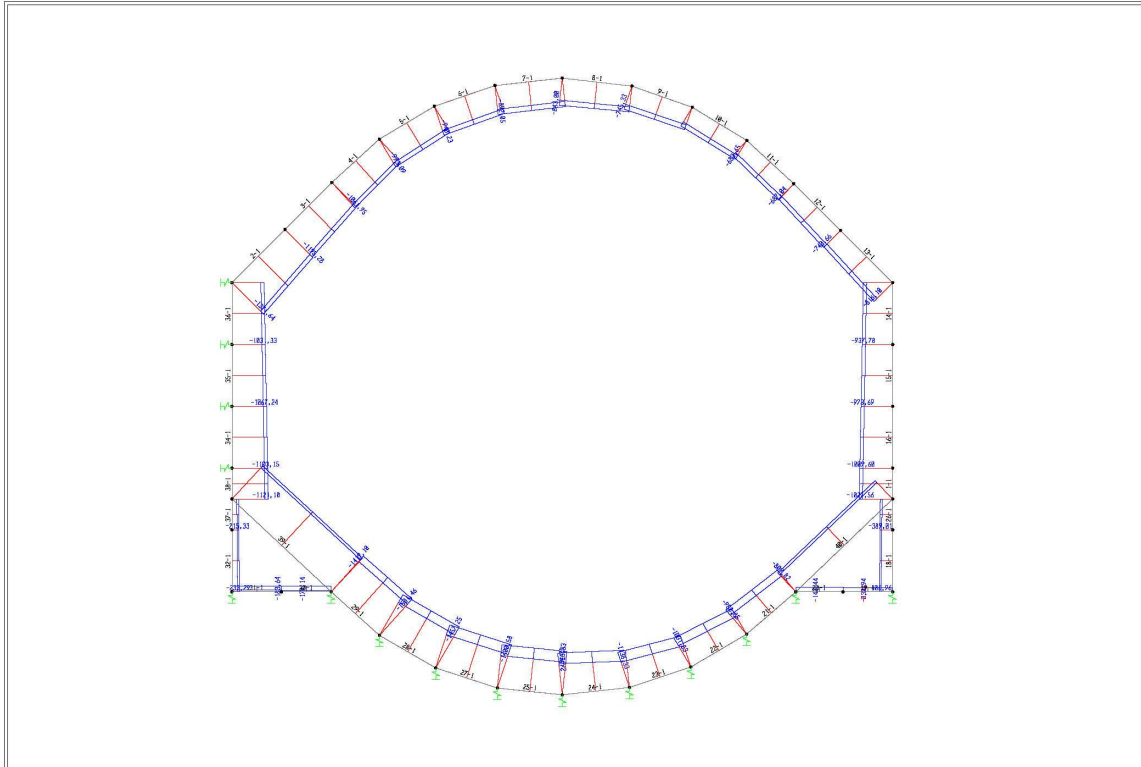

SAP2000 v14.2.2 - File:Ormenis Seismic - Axial Force Diagram (ENVELOPE_ULS) - KN, m, C Units

SAP2000

11/8/11 15:47:46

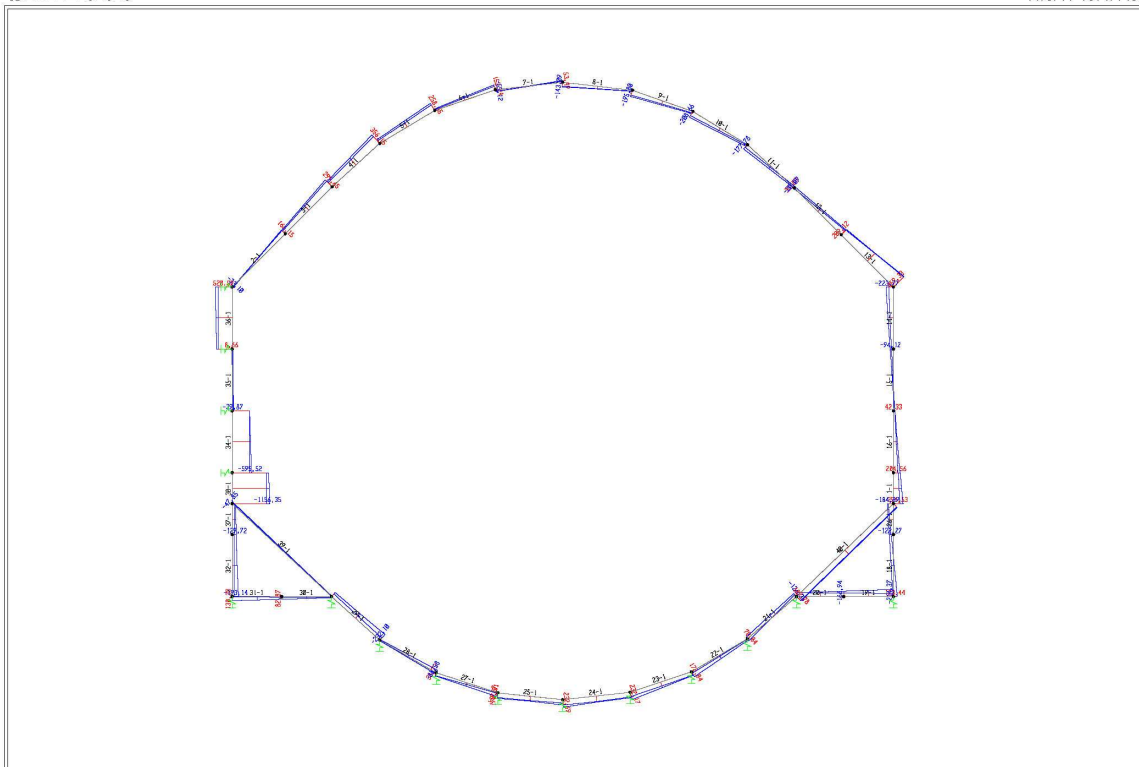

SAP2000 v14.2.2 - File:Ormenis Seismic - Shear Force 2-2 Diagram (ENVELOPE_ULS) - KN, m, C Units

REHABILITATION OF THE RAILWAY LINE BRASOV – SIMERIA, COMPONENT PART OF IV PAN-EUROPEAN CORRIDOR FOR THE TRAINS CIRCULATION WITH MAXIMUM SPEED OF 160 KM/H.

STAREA LIMITĂ DE DESERVIRE

SAP2000

11/8/11 15:49:52

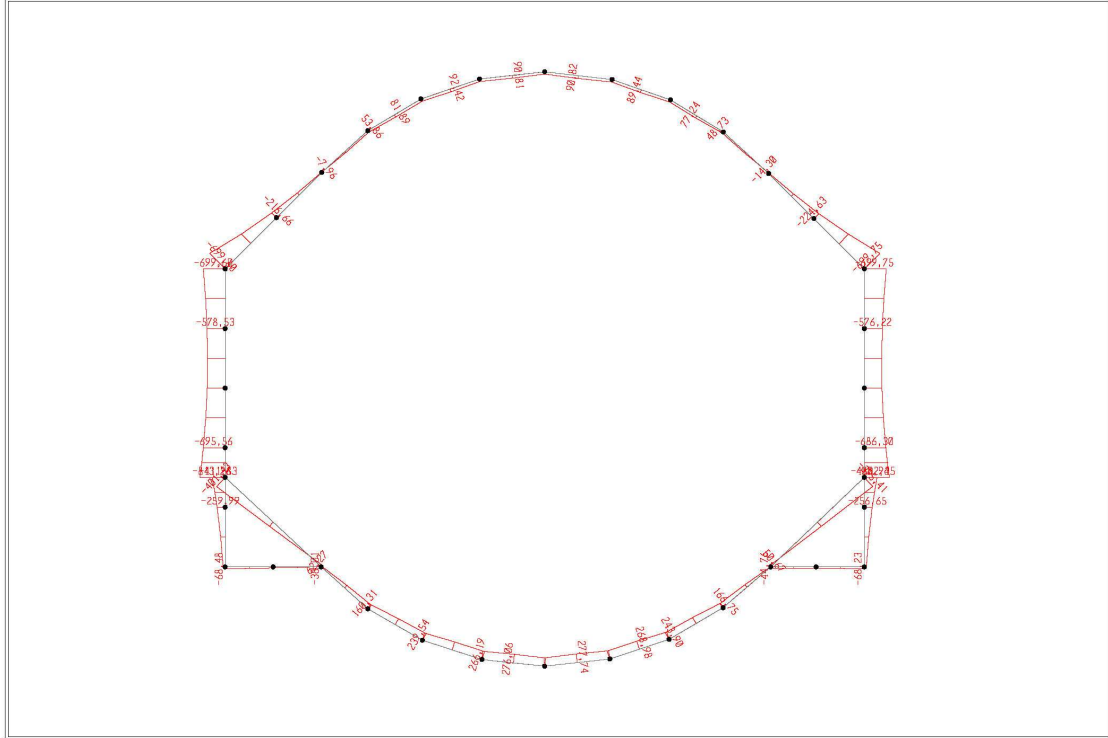

SAP2000 v14.2.2 - File:Ormenis Static - Moment 3-3 Diagram (SLS) - KN, m, C Units

SAP2000

11/8/11 15:50:52

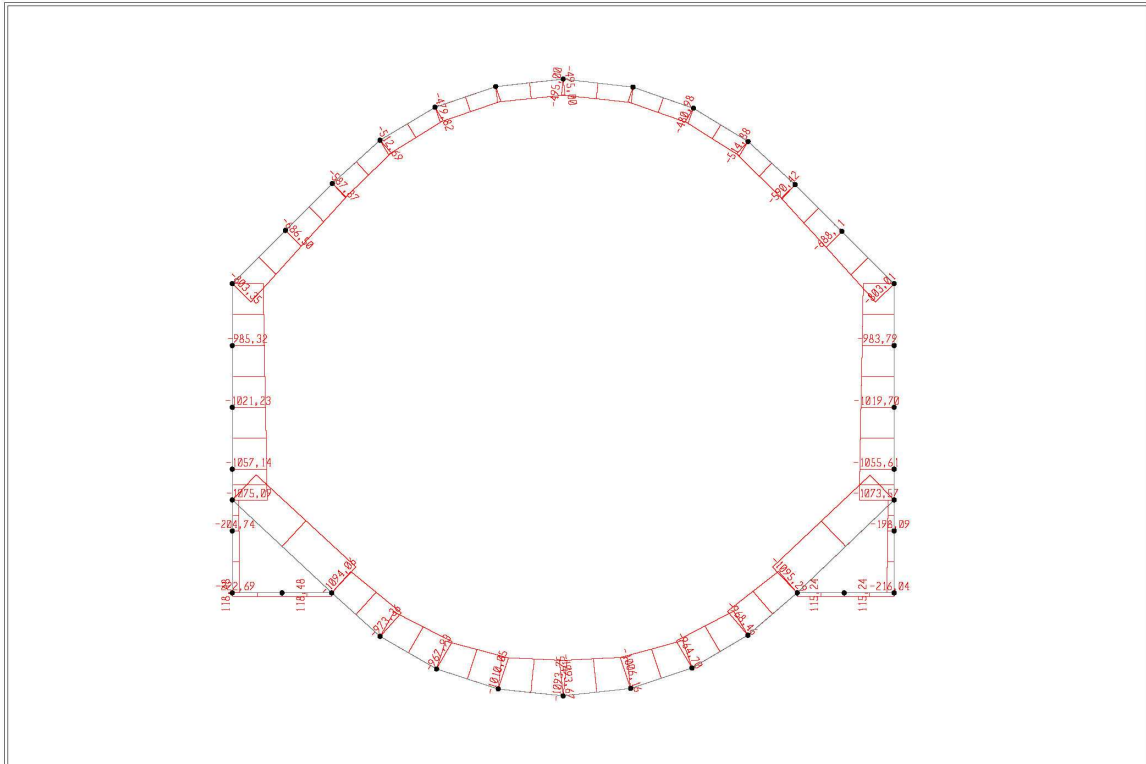

SAP2000 v14.2.2 - File:Ormenis Static - Axial Force Diagram (SLS) - KN, m, C Units

REHABILITATION OF THE RAILWAY LINE BRASOV – SIMERIA, COMPONENT PART OF IV PAN-EUROPEAN CORRIDOR FOR THE TRAINS CIRCULATION WITH MAXIMUM SPEED OF 160 KM/H.

SAP2000

11/8/11 15:51:48

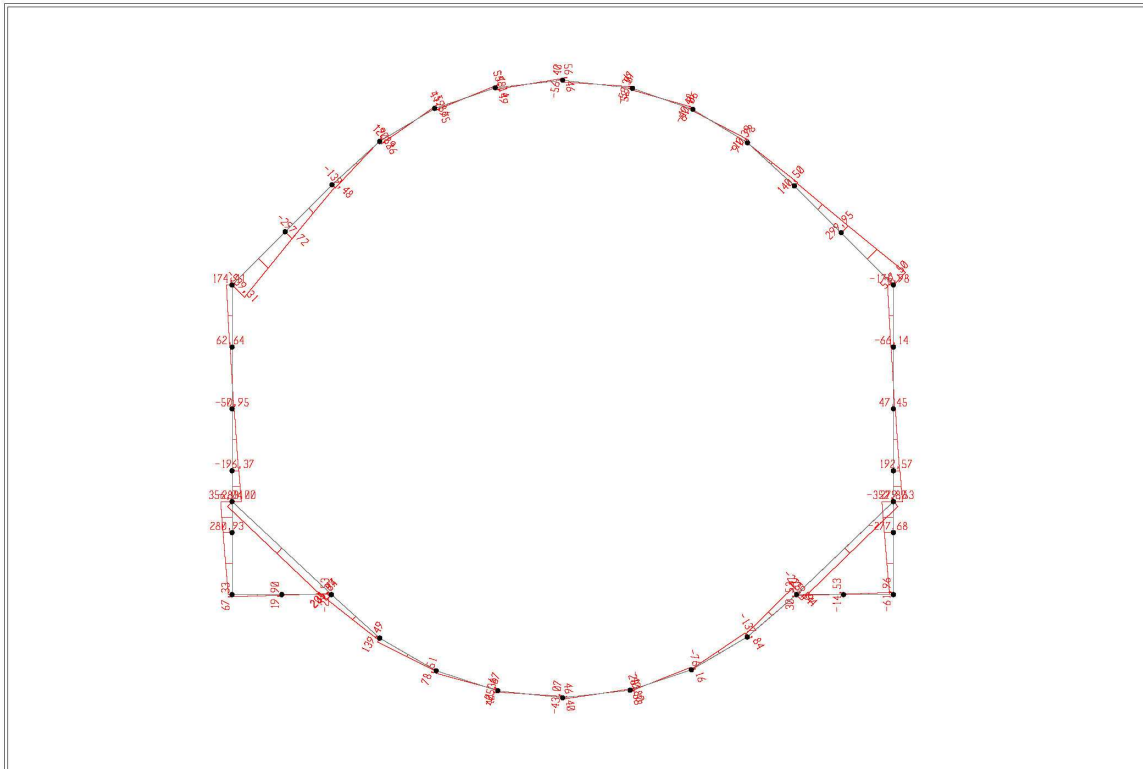

SAP2000 v14.2.2 - File:Ormenis Static - Shear Force 2-2 Diagram (SLS) - KN, m, C Units

Secțiunea	B	H	ULS STATIC			ULS SEISMIC			SLS		
	cm	cm									
1	100	80	M=	191	kNm	M=	219	kNm	M=	90.8	kNm
			N=	471.3	kN	N=	881	kN	N=	485.8	kN
			T=	53.4	kN	T=	35.6	kN	T=	2.2	kN
2	100	160	M=	1087.6	kNm	M=	680	kNm	M=	699.6	kNm
			N=	1084.5	kN	N=	995	kN	N=	803.4	kN
			T=	728	kN	T=	520	kN	T=	539	kN
3	100	160	M=	1244.8	kNm	M=	1157	kNm	M=	813	kNm
			N=	1449.1	kN	N=	930.9	kN	N=	1075	kN
			T=	505.6	kN	T=	1159	kN	T=	319	kN
4	100	100	M=	530	kNm	M=	338	kNm	M=	276	kNm
			N=	954	kN	N=	1457	kN	N=	1035	kN
			T=	337	kN	T=	232	kN	T=	225	kN

REHABILITATION OF THE RAILWAY LINE BRASOV – SIMERIA, COMPONENT PART OF IV PAN-EUROPEAN CORRIDOR FOR THE TRAINS CIRCULATION WITH MAXIMUM SPEED OF 160 KM/H.

6.8. Verificări structurale ULS

Secțiunea 1

Caracteristici			
Materiale			
C 30/37			
fcd	Mpa	17	
B450C			
fyd	MPa	391	
Secțiunea			
b	cm	100	
h	cm	80	
As	cm ²	12.72	5 ϕ 18
A's	cm ²	12.72	5 ϕ 18
c	cm	5	
d	cm	75	
Mrd	kN*m	366.5	

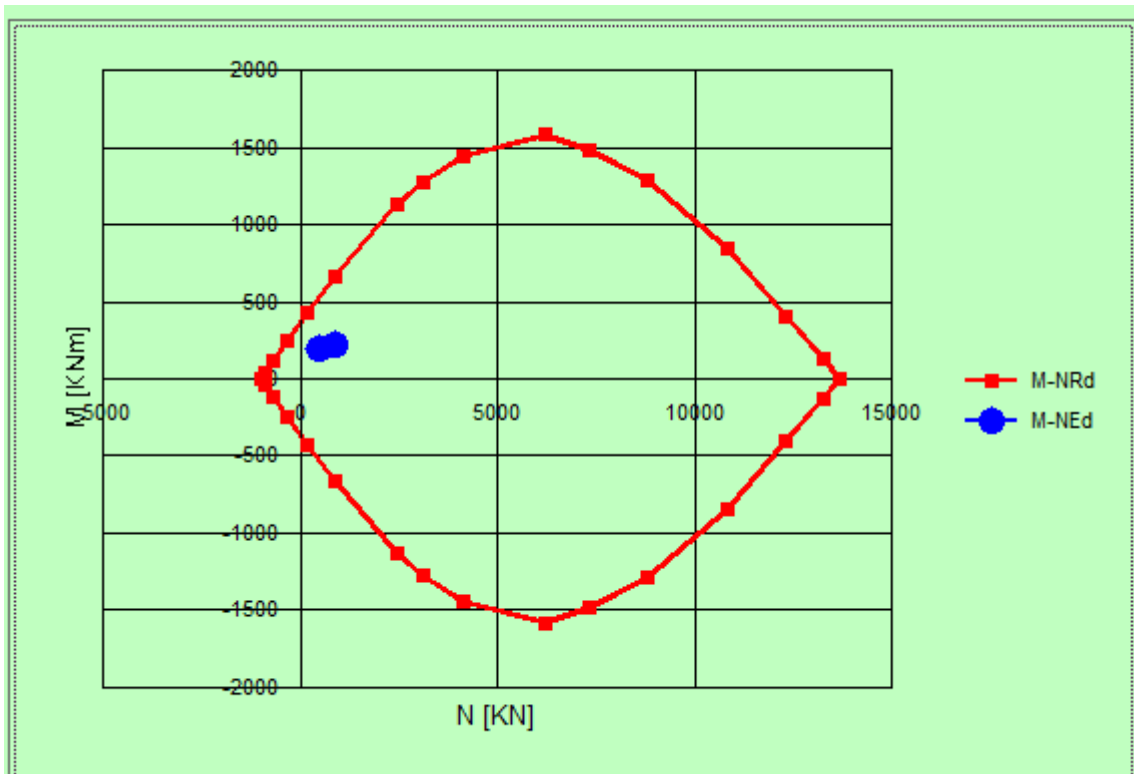

REHABILITATION OF THE RAILWAY LINE BRASOV – SIMERIA, COMPONENT PART OF IV PAN-EUROPEAN CORRIDOR FOR THE TRAINS CIRCULATION WITH MAXIMUM SPEED OF 160 KM/H.

Caracteristici		
Materiale		
C 30/37		
fcd	Mpa	17
B450C		
fyd	MPa	391
Secțiunea		
b	cm	100
h	cm	80
As	cm ²	12.72
A's	cm ²	12.72
c	cm	5
d	cm	245
Tsd	kN*m	53
V _{Rd1}	kN	264 > 53
		Nu este necesară armătură de forfecare

REHABILITATION OF THE RAILWAY LINE BRASOV – SIMERIA, COMPONENT PART OF IV PAN-EUROPEAN CORRIDOR FOR THE TRAINS CIRCULATION WITH MAXIMUM SPEED OF 160 KM/H.

Sectiunea 2

Caracteristici			
Materiale			
C 30/37			
fcd	Mpa	17	
B450C			
fyd	MPa	391	
Sectiunea			
b	cm	100	
h	cm	160	
As	cm2	18.85	6 ϕ 20
A's	cm2	18.85	6 ϕ 20
c	cm	5	
d	cm	155	
Mrd	kN*m	1933	

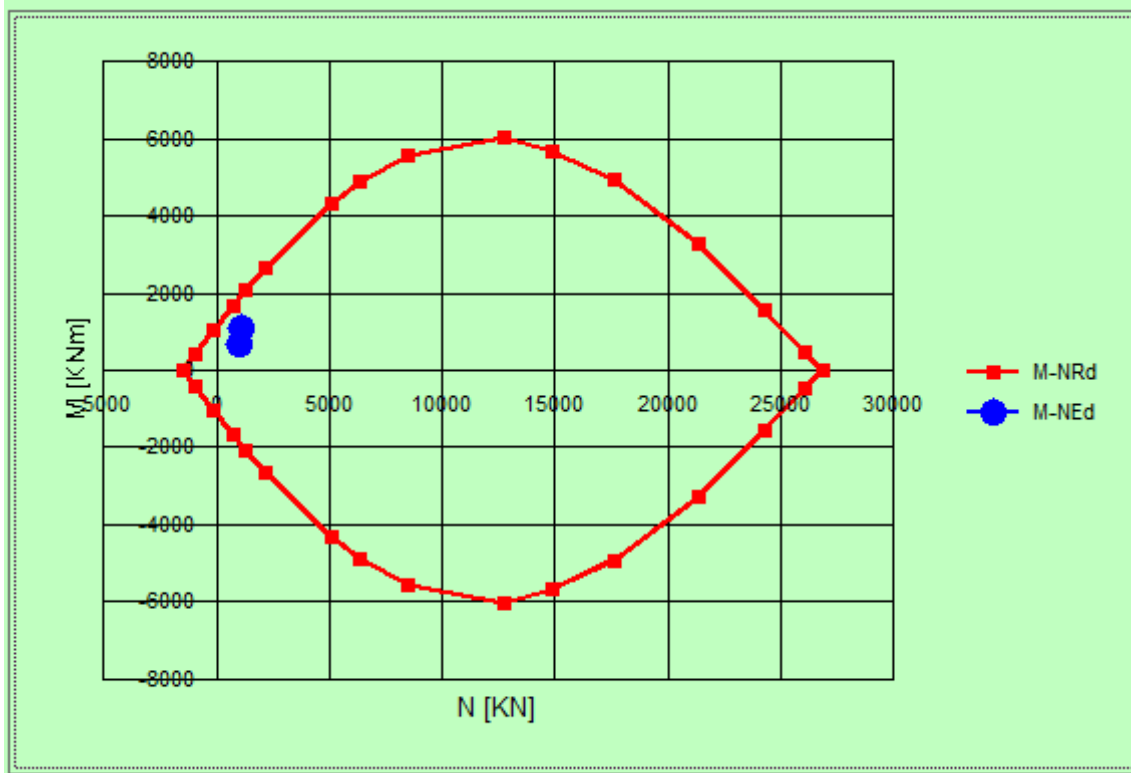

REHABILITATION OF THE RAILWAY LINE BRASOV – SIMERIA, COMPONENT PART OF IV PAN-EUROPEAN CORRIDOR FOR THE TRAINS CIRCULATION WITH MAXIMUM SPEED OF 160 KM/H.

Caratteristici		
Materiale		
C 30/37		
fcd	Mpa	17
B450C		
fyd	MPa	391
Secțiunea		
b	cm	100
h	cm	160
As	cm ²	18.85
A's	cm ²	18.85
c	cm	5
d	cm	155
Tsd	kN*m	728
V _{Rd1}	kN	463 < 728
		Necesară armătură de forfecare
ctgθ =		2,5
θ	(°)	21.8
Ast	cm ² /m	15.39 (2φ14/20 cm)
V _{Rsd}	kN	2100
V _{Rcd}	kN	3959
VRdu	kN	2100

REHABILITATION OF THE RAILWAY LINE BRASOV – SIMERIA, COMPONENT PART OF IV PAN-EUROPEAN CORRIDOR FOR THE TRAINS CIRCULATION WITH MAXIMUM SPEED OF 160 KM/H.

Sectiunea 3

Caracteristici			
Materiale			
C 30/37			
fcd	Mpa	17	
B450C			
fyd	MPa	391	
Sectiunea			
b	cm	100	
h	cm	160	
As	cm2	18.85	6 ϕ 20
A's	cm2	18.85	6 ϕ 20
c	cm	5	
d	cm	155	
Mrd	kN*m	2197	

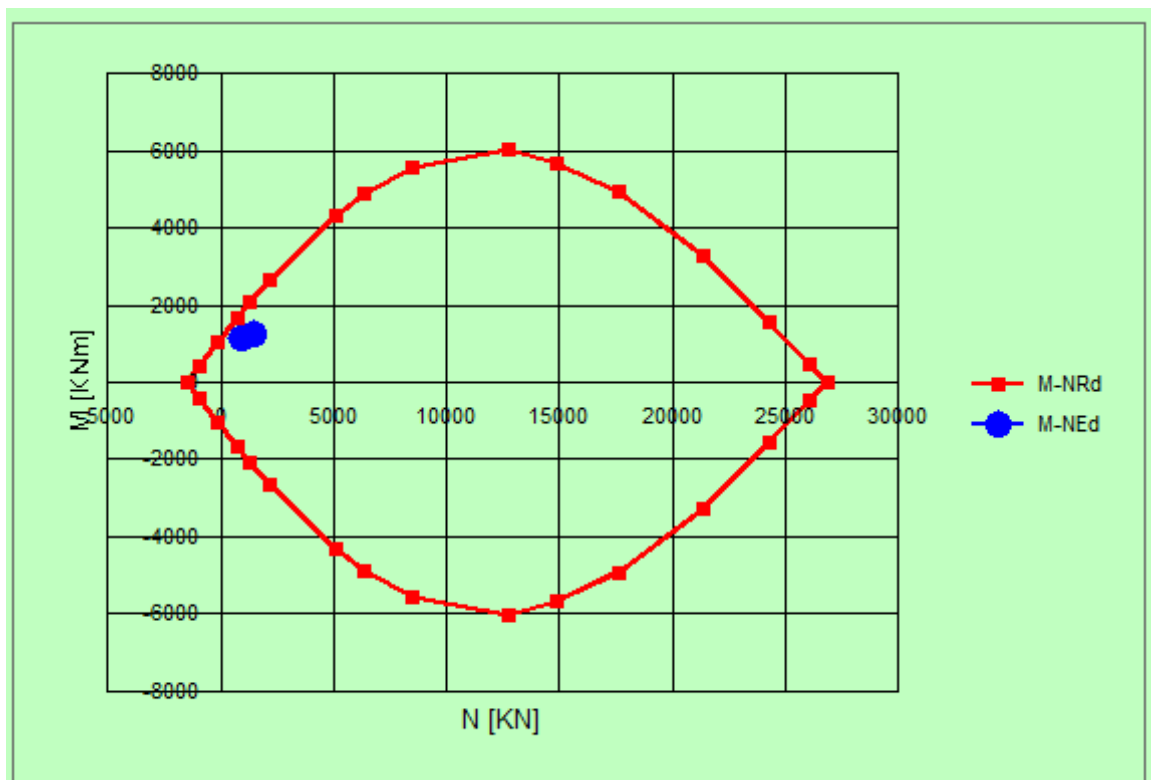

REHABILITATION OF THE RAILWAY LINE BRASOV – SIMERIA, COMPONENT PART OF IV PAN-EUROPEAN CORRIDOR FOR THE TRAINS CIRCULATION WITH MAXIMUM SPEED OF 160 KM/H.

Caratteristiche		
Materiale		
C 30/37		
fcd	Mpa	17
B450C		
fyd	MPa	391
Sețiunea		
b	cm	100
h	cm	160
As	cm ²	18.85
A's	cm ²	18.85
c	cm	5
d	cm	155
Tsd	kN*m	1125
V _{Rd1}	kN	463 < 1125
		Necesară armătură de forfecare
ctgθ =		2,5
θ	(°)	21.8
Ast	cm ² /m	15.39 (2φ14/20 cm)
V _{Rsd}	kN	2100
V _{Rcd}	kN	3959
VRdu	kN	2100

REHABILITATION OF THE RAILWAY LINE BRASOV – SIMERIA, COMPONENT PART OF IV PAN-EUROPEAN CORRIDOR FOR THE TRAINS CIRCULATION WITH MAXIMUM SPEED OF 160 KM/H.

Sectiunea 4

Caracteristici			
Materiale			
C 30/37			
fcd	Mpa	17	
B450C			
fyd	MPa	391	
Sectiunea			
b	cm	100	
h	cm	100	
As	cm2	15.71	5 ϕ 20
A's	cm2	15.71	5 ϕ 20
c	cm	5	
d	cm	95	
Mrd	kN*m	1205	

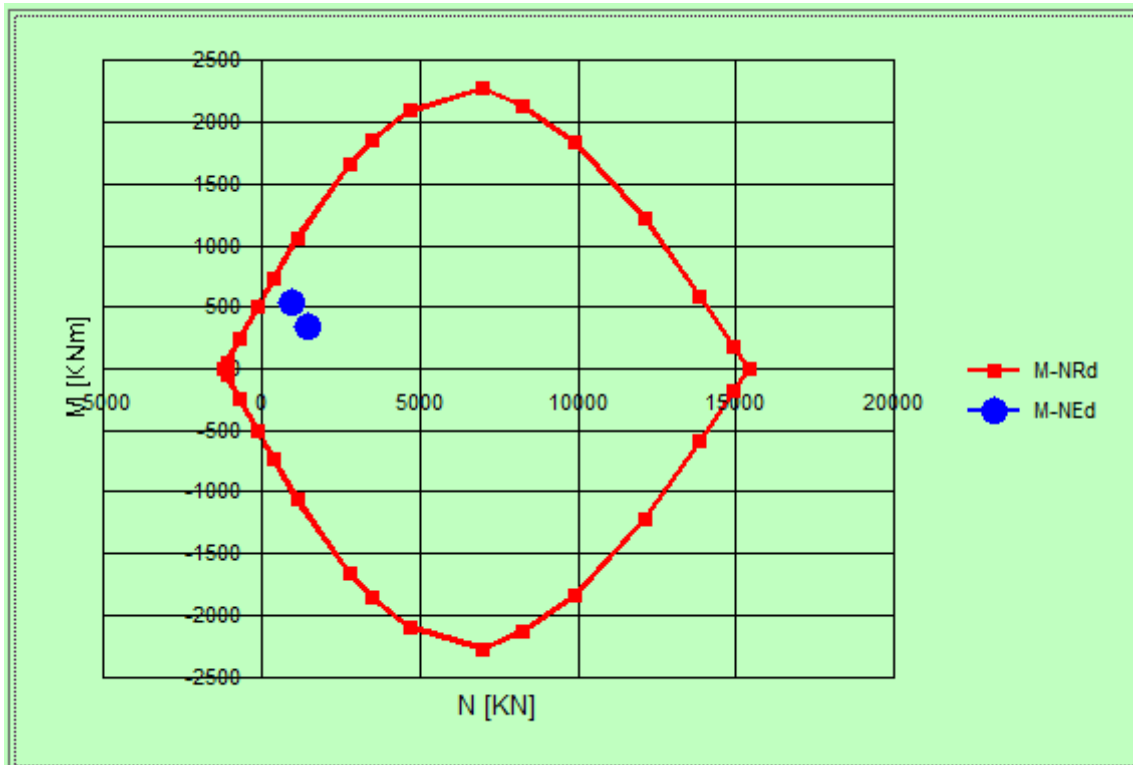

REHABILITATION OF THE RAILWAY LINE BRASOV – SIMERIA, COMPONENT PART OF IV PAN-EUROPEAN CORRIDOR FOR THE TRAINS CIRCULATION WITH MAXIMUM SPEED OF 160 KM/H.

Caracteristici		
Materiale		
C 30/37		
fcd	Mpa	15.87
B450C		
fyd	MPa	391
Secțiunea		
b	cm	100
h	cm	100
As	cm ²	15.71
A's	cm ²	15.71
c	cm	5
d	cm	95
Tsd	kN*m	337
V _{Rd1}	kN	355 > 337
		Nu este necesară armătură de forfecare

6.9. Verificări SLS

Secțiunea	B	H	Armătură		M	N	σ _s
			n.	n.			
1	100	80	5φ18	5φ18	90.8	485.8	2.3
2	100	160	6φ20	6φ20	699.6	803.4	77.85
3	100	160	6φ20	6φ20	813	1075	69.2
4	100	100	5φ20	5φ20	276	1035	Comp.

REHABILITATION OF THE RAILWAY LINE BRASOV – SIMERIA, COMPONENT PART OF IV PAN-EUROPEAN CORRIDOR FOR THE TRAINS CIRCULATION WITH MAXIMUM SPEED OF 160 KM/H.

REFERINȚĂ 1992-1-1 paragraf 7.3

h	1600	[mm]
b	1000	[mm]
d	1550	[mm]
d'	50	[mm]
c	40	[mm]
$n_{f,1}$	6	[-]
$\phi_{f,1}$	20	[mm]
$A_{sf,1}$	1885	[mm ²]
$n_{f,2}$	0	[-]
$\phi_{f,2}$	0	[mm]
$A_{sf,2}$	0	[mm ²]
f_{ck}	37	[MPa]
f_{ctm}	3,2	[MPa]
E_{cm}	34077	[MPa]
f_{yk}	450	[MPa]
E_s	200000	[MPa]
σ_s	77,79	[MPa]
x	573	[mm]
α_e	5,87	[-]
A_s	1885	[mm ²]
$A_{c,eff.1}$	125000	[mm ²]
$A_{c,eff.2}$	342333	[mm ²]
$A_{c,eff.3}$	800000	[mm ²]
$A_{c,eff.min}$	125000	[mm ²]
$\rho_{p,eff}$	0,01508	[-]
$f_{ct,eff}$	3,2	[MPa]
k_t	0,4	[-]
$[\epsilon_{sm} - \epsilon_{cm}]_{min}$	0,000233	[-]
$[\epsilon_{sm} - \epsilon_{cm}]_{calc.}$	-0,000074	[-]
$[\epsilon_{sm} - \epsilon_{cm}]$	0,000233	[-]
s	166	[mm]
ϕ_{eq}	20,00	[mm]
$S_{max,rif}$	250	[mm]
k_1	0,800	[-]
k_2	1,000	[-]
k_3	3,400	[-]
k_4	0,425	[-]
$S_{r,max.1}$	587	[mm]
$S_{r,max.2}$	1335	[mm]
$S_{r,max}$	587	[mm]
$W_{k,lim}$	0,30	[mm]
W_k	0,14	[mm]

7. CONCLUZII

În acest raport ne ocupăm cu problemele de proiectare referitoare la implementarea lucrărilor de construcții ale intrărilor de tunel de-a lungul aliniamentului de cale ferată Brașov – Sighișoara ce aparține rețelei de căi ferate ale Coridorului IV Pan European. Evaluările efectuate au confirmat valabilitatea soluțiilor de proiectare adoptate, cu referire atât la structurile temporare cât și la cele permanente. Verificările statice efectuate au arătat solicitări ale materialului mai mici decât valorile permisibile conform regulilor.

PARATIE 7.00
15 NOVEMBRE 2011 18:05:24
History 0 - ORMENIS

Ce.A.S. s.r.l. - Milano

PAG. 1

```
*****  
**  
**          P  A  R  A  T  I  E          **  
**  
**          RELEASE 7.00  VERSIONE WIN  **  
**  
**  Ce.A.S. s.r.l. - Viale Giustiniano, 10  **  
**                      20129 MILANO      **  
**  
*****
```

JOBNAME C:\Users\Tecnico5\Desktop\Nuova cartella (3)\File Paratie Ormenis L

15 NOVEMBRE 2011 18:05:24

ELENCO DEI DATI DI INPUT(PARAGEN)

Per il significato dei vari comandi
si faccia riferimento al manuale di
input PARAGEN, versione 7.00.

N. comando

```
1: * Paratie for Windows version 7.0
2: * Filename= <c:\users\tecnico5\desktop\nuova cartella (3)\ormenis lato
  ormenis\s
3: * project with "run time" parameters
4: * Force=kN Lenght=m
5: *
6: units m kN
7: title History 0 - ORMENIS
8: delta 0.2
9: option param itemax 20
10: option noprint echo
11: option noprint displ
12: option noprint react
13: option noprint stresses
14:   wall RightWall 0 -30 0
15: *
16: soil DHRight RightWall -30 0 2 0
17: soil UHRight RightWall -30 0 1 180
18: *
19: material Pali 3.2308E+007
20: material Acciaio 2.1E+008
21: *
22: beam Right_wall RightWall -22 0 Pali 0.979439 00 00
23: *
24: wire Wire01 RightWall -0.5 Acciaio 2.87179E-005 150 157.5
25: wire Wire2 RightWall -4 Acciaio 4.30769E-005 150 157.5
26: *
27: * Soil Profile
28: *
29:   ldata      Soil 0
30:     weight   19 9 10
31:     atrest   1 0.5 1
32:     resistance 0 25 0.359 3.319
33:     young    18000 23000
34:   endlayer
35:   ldata      Soil2 -5
36:     weight   21 11 10
37:     atrest   1 0.5 1
38:     resistance 20 28 0.317 3.929
```

PARATIE 7.00
15 NOVEMBRE 2011 18:05:24
History 0 - ORMENIS

Ce.A.S. s.r.l. - Milano

PAG. 3

N. comando

```
39:      young      20000 25000
40:      endlayer
41:      ldata      Soil3 -15
42:      weight     21 11 10
43:      atrest     1 0.5 1
44:      resistance 40 28 0.317 3.929
45:      young      30000 35000
46:      endlayer
47: *
48: step 1 :
49:      setwall RightWall
50:      geom 0 -0.5
51:      add Wire01
52: endstep
53: *
54: step 2 :
55:      setwall RightWall
56:      geom 0 -4
57:      water -2 2
58: endstep
59: *
60: step 3 :
61:      setwall RightWall
62:      add Wire2
63: endstep
64: *
65: step 4 :
66:      setwall RightWall
67:      geom 0 -7.5
68:      water -2 5.5
69:      surcharge 23 0 0 0
70: endstep
71: *
72: *
```

RIASSUNTO PARAMETRI GEOTECNICI PER LA FASE 1

LAYER Soil			
natura 1=granulare, 2=argilla	=	1.0000	
quota superiore	=	0.0000	m
quota inferiore	=	-5.0000	m
peso fuori falda	=	19.000	kN/m ³
peso efficace in falda	=	9.0000	kN/m ³
peso dell'acqua	=	10.000	kN/m ³
angolo di attrito	=	25.000	DEG (A MONTE)
coeff. spinta attiva ka	=	0.35900	(A MONTE)
coeff. spinta passiva kp	=	3.3190	(A MONTE)
Konc normal consolidato	=	1.0000	
esponente di OCR	=	0.50000	
OCR: grado di sovraconsolidazione	=	1.0000	
modello di rigidezza	=	1.0000	
modulo el. compr. vergine	=	18000.	kPa
modulo el. scarico/ricarico	=	23000.	kPa
natura 1=granulare, 2=argilla	=	1.0000	(A VALLE)
angolo di attrito	=	25.000	DEG (A VALLE)
coeff. spinta attiva ka	=	0.35900	(A VALLE)
coeff. spinta passiva kp	=	3.3190	(A VALLE)
LAYER Soil2			
natura 1=granulare, 2=argilla	=	1.0000	
quota superiore	=	-5.0000	m
quota inferiore	=	-15.000	m
peso fuori falda	=	21.000	kN/m ³
peso efficace in falda	=	11.000	kN/m ³
peso dell'acqua	=	10.000	kN/m ³
coesione	=	20.000	kPa (A MONTE)
angolo di attrito	=	28.000	DEG (A MONTE)
coeff. spinta attiva ka	=	0.31700	(A MONTE)
coeff. spinta passiva kp	=	3.9290	(A MONTE)
Konc normal consolidato	=	1.0000	
esponente di OCR	=	0.50000	
OCR: grado di sovraconsolidazione	=	1.0000	
modello di rigidezza	=	1.0000	
modulo el. compr. vergine	=	20000.	kPa
modulo el. scarico/ricarico	=	25000.	kPa
natura 1=granulare, 2=argilla	=	1.0000	(A VALLE)
coesione	=	20.000	kPa (A VALLE)
angolo di attrito	=	28.000	DEG (A VALLE)
coeff. spinta attiva ka	=	0.31700	(A VALLE)

RIASSUNTO PARAMETRI GEOTECNICI PER LA FASE 1

coeff. spinta passiva kp = 3.9290 (A VALLE)

LAYER Soil3

natura 1=granulare, 2=argilla = 1.0000
quota superiore = -15.000 m
quota inferiore = -0.10000E+31 m
peso fuori falda = 21.000 kN/m³
peso efficace in falda = 11.000 kN/m³
peso dell'acqua = 10.000 kN/m³
coesione = 40.000 kPa (A MONTE)
angolo di attrito = 28.000 DEG (A MONTE)
coeff. spinta attiva ka = 0.31700 (A MONTE)
coeff. spinta passiva kp = 3.9290 (A MONTE)
Konc normal consolidato = 1.0000
esponente di OCR = 0.50000
OCR: grado di sovraconsolidazione = 1.0000
modello di rigidezza = 1.0000
modulo el. compr. vergine = 30000. kPa
modulo el. scarico/ricarico = 35000. kPa
natura 1=granulare, 2=argilla = 1.0000 (A VALLE)
coesione = 40.000 kPa (A VALLE)
angolo di attrito = 28.000 DEG (A VALLE)
coeff. spinta attiva ka = 0.31700 (A VALLE)
coeff. spinta passiva kp = 3.9290 (A VALLE)

RIASSUNTO PARAMETRI GEOTECNICI PER LA FASE 2

(SOLO I PARAMETRI CHE POSSONO VARIARE)

NESSUN CAMBIAMENTO RISPETTO AL PASSO PRECEDENTE

RIASSUNTO PARAMETRI GEOTECNICI PER LA FASE 3

(SOLO I PARAMETRI CHE POSSONO VARIARE)

NESSUN CAMBIAMENTO RISPETTO AL PASSO PRECEDENTE

RIASSUNTO PARAMETRI GEOTECNICI PER LA FASE 4

(SOLO I PARAMETRI CHE POSSONO VARIARE)

NESSUN CAMBIAMENTO RISPETTO AL PASSO PRECEDENTE

RIASSUNTO DATI RELATIVI ALLA FASE 1

WALL RightWall

coordinata y	=	0.0000	m
quota piano campagna	=	0.0000	m
quota del fondo scavo	=	-0.50000	m
quota della falda	=	-0.99900E+30	m
sovraccarico a monte	=	0.0000	kPa
quota del sovraccarico a monte	=	0.0000	m
depressione falda a valle	=	0.0000	m
sovraccarico a valle	=	0.0000	kPa
quota del sovraccarico a valle	=	-0.99900E+30	m
quota di taglio	=	0.0000	m
quota di equil. pressioni dell'acqua	=	-30.000	m
indicatore comportamento acqua	=	0.0000	(1=REMOVE)
opzione aggiornamento pressioni acqua	=	0.0000	(1=NO UPD)

RIASSUNTO DATI RELATIVI ALLA FASE 2

WALL RightWall

coordinata y	=	0.0000	m
quota piano campagna	=	0.0000	m
quota del fondo scavo	=	-4.0000	m
quota della falda	=	-2.0000	m
sovraccarico a monte	=	0.0000	kPa
quota del sovraccarico a monte	=	0.0000	m
depressione falda a valle	=	2.0000	m
sovraccarico a valle	=	0.0000	kPa
quota del sovraccarico a valle	=	-0.99900E+30	m
quota di taglio	=	0.0000	m
quota di equil. pressioni dell'acqua	=	-30.000	m
indicatore comportamento acqua	=	0.0000	(1=REMOVE)
opzione aggiornamento pressioni acqua	=	0.0000	(1=NO UPD)

RIASSUNTO DATI RELATIVI ALLA FASE 3

WALL RightWall

coordinata y	=	0.0000	m
quota piano campagna	=	0.0000	m
quota del fondo scavo	=	-4.0000	m
quota della falda	=	-2.0000	m
sovraccarico a monte	=	0.0000	kPa

PARATIE 7.00
15 NOVEMBRE 2011 18:05:24
History 0 - ORMENIS

Ce.A.S. s.r.l. - Milano

PAG. 7

RIASSUNTO DATI RELATIVI ALLA FASE 3

quota del sovraccarico a monte	= 0.0000	m
depressione falda a valle	= 2.0000	m
sovraccarico a valle	= 0.0000	kPa
quota del sovraccarico a valle	= -0.99900E+30	m
quota di taglio	= 0.0000	m
quota di equil. pressioni dell'acqua	= -30.000	m
indicatore comportamento acqua	= 0.0000	(1=REMOVE)
opzione aggiornamento pressioni acqua	= 0.0000	(1=NO UPD)

RIASSUNTO DATI RELATIVI ALLA FASE 4

WALL RightWall

coordinata y	= 0.0000	m
quota piano campagna	= 0.0000	m
quota del fondo scavo	= -7.5000	m
quota della falda	= -2.0000	m
sovraccarico a monte	= 23.000	kPa
quota del sovraccarico a monte	= 0.0000	m
depressione falda a valle	= 5.5000	m
sovraccarico a valle	= 0.0000	kPa
quota del sovraccarico a valle	= 0.0000	m
quota di taglio	= 0.0000	m
quota di equil. pressioni dell'acqua	= -30.000	m
indicatore comportamento acqua	= 0.0000	(1=REMOVE)
opzione aggiornamento pressioni acqua	= 0.0000	(1=NO UPD)

RIASSUNTO ELEMENTI
=====

RIASSUNTO ELEMENTI SOIL						
Name	Wall	Z1	Z2	Flag	Angle	
		m	m		deg	
DHRight	RightWall	0.	-30.00	DOWNHILL	0.	
UHRight	RightWall	0.	-30.00	UPHILL	180.0	

RIASSUNTO ELEMENTI BEAM						
Name	Wall	Z1	Z2	Mat	thick	
		m	m		m	
Right_wall	RightWall	0.	-22.00	_	0.9794	

RIASSUNTO ELEMENTI WIRE						
Name	Wall	Zeta	Mat	A/L	Pinit	Angle
		m			kN/m	deg
Wire01	RightWall	-.5000	_	0.2872E-04	150.0	157.5
Wire2	RightWall	-4.000	_	0.4308E-04	150.0	157.5

PARATIE 7.00
15 NOVEMBRE 2011 18:05:24
History 0 - ORMENIS

Ce.A.S. s.r.l. - Milano

PAG. 9

RIASSUNTO DATI VARI
=====

MATERIALI	
Name	YOUNG MODULUS
	kPa
Pali	3.2308E+007
Acci	2.1E+008

PARATIE 7.00

Ce.A.S. s.r.l. - Milano

PAG. 10

15 NOVEMBRE 2011 18:05:24

History 0 - ORMENIS

RIASSUNTO ANALISI INCREMENTALE

FASE	N. DI ITERAZIONI	CONVERGENZA
1	3	SI
2	3	SI
3	3	SI
4	3	SI

MASSIMI SPOSTAMENTI LATERALI

TUTTI I PASSI

* PARETE RightWall*

* I PASSI NON EQUILIBRATI SONO ESCLUSI *

* NOTA: LE QUOTE ESPRESSE IN m

E GLI SPOSTAMENTI IN m

NODO	QUOTA ZETA	SPOSTAMENTO MASSIMO	FASE PARETE RightWall
1	0.0000	0.35825E-02	1
2	-0.20000	0.34344E-02	1
3	-0.40000	-0.37663E-02	4
4	-0.50000	-0.39624E-02	4
5	-0.70000	-0.43545E-02	4
6	-0.90000	-0.47461E-02	4
7	-1.1000	-0.51367E-02	4
8	-1.3000	-0.55259E-02	4
9	-1.5000	-0.59130E-02	4
10	-1.7000	-0.62978E-02	4
11	-1.9000	-0.66797E-02	4
12	-2.1000	-0.70585E-02	4
13	-2.3000	-0.74336E-02	4
14	-2.5000	-0.78047E-02	4
15	-2.7000	-0.81716E-02	4
16	-2.9000	-0.85339E-02	4
17	-3.1000	-0.88913E-02	4
18	-3.3000	-0.92436E-02	4
19	-3.5000	-0.95905E-02	4
20	-3.7000	-0.99320E-02	4
21	-3.9000	-0.10268E-01	4
22	-4.0000	-0.10434E-01	4
23	-4.2000	-0.10761E-01	4
24	-4.4000	-0.11081E-01	4
25	-4.6000	-0.11394E-01	4
26	-4.8000	-0.11700E-01	4
27	-5.0000	-0.11997E-01	4
28	-5.2000	-0.12285E-01	4
29	-5.4000	-0.12563E-01	4
30	-5.6000	-0.12831E-01	4
31	-5.8000	-0.13089E-01	4
32	-6.0000	-0.13336E-01	4
33	-6.2000	-0.13572E-01	4
34	-6.4000	-0.13796E-01	4
35	-6.6000	-0.14009E-01	4
36	-6.8000	-0.14210E-01	4
37	-7.0000	-0.14398E-01	4
38	-7.2000	-0.14575E-01	4

NODO	QUOTA ZETA	SPOSTAMENTO MASSIMO	FASE PARETE RightWall
39	-7.4000	-0.14739E-01	4
40	-7.6000	-0.14891E-01	4
41	-7.8000	-0.15032E-01	4
42	-8.0000	-0.15160E-01	4
43	-8.2000	-0.15277E-01	4
44	-8.4000	-0.15382E-01	4
45	-8.6000	-0.15476E-01	4
46	-8.8000	-0.15559E-01	4
47	-9.0000	-0.15631E-01	4
48	-9.2000	-0.15693E-01	4
49	-9.4000	-0.15744E-01	4
50	-9.6000	-0.15785E-01	4
51	-9.8000	-0.15816E-01	4
52	-10.000	-0.15837E-01	4
53	-10.200	-0.15850E-01	4
54	-10.400	-0.15853E-01	4
55	-10.600	-0.15847E-01	4
56	-10.800	-0.15832E-01	4
57	-11.000	-0.15810E-01	4
58	-11.200	-0.15779E-01	4
59	-11.400	-0.15741E-01	4
60	-11.600	-0.15695E-01	4
61	-11.800	-0.15642E-01	4
62	-12.000	-0.15583E-01	4
63	-12.200	-0.15516E-01	4
64	-12.400	-0.15444E-01	4
65	-12.600	-0.15365E-01	4
66	-12.800	-0.15281E-01	4
67	-13.000	-0.15191E-01	4
68	-13.200	-0.15096E-01	4
69	-13.400	-0.14996E-01	4
70	-13.600	-0.14892E-01	4
71	-13.800	-0.14783E-01	4
72	-14.000	-0.14671E-01	4
73	-14.200	-0.14555E-01	4
74	-14.400	-0.14435E-01	4
75	-14.600	-0.14313E-01	4
76	-14.800	-0.14187E-01	4
77	-15.000	-0.14060E-01	4
78	-15.200	-0.13930E-01	4
79	-15.400	-0.13799E-01	4
80	-15.600	-0.13666E-01	4
81	-15.800	-0.13532E-01	4
82	-16.000	-0.13397E-01	4
83	-16.200	-0.13261E-01	4
84	-16.400	-0.13124E-01	4

PARATIE 7.00

Ce.A.S. s.r.l. - Milano

PAG. 13

15 NOVEMBRE 2011 18:05:24

History 0 - ORMENIS

NODO	QUOTA ZETA	SPOSTAMENTO MASSIMO	FASE PARETE RightWall
85	-16.600	-0.12988E-01	4
86	-16.800	-0.12851E-01	4
87	-17.000	-0.12713E-01	4
88	-17.200	-0.12576E-01	4
89	-17.400	-0.12439E-01	4
90	-17.600	-0.12302E-01	4
91	-17.800	-0.12165E-01	4
92	-18.000	-0.12029E-01	4
93	-18.200	-0.11893E-01	4
94	-18.400	-0.11757E-01	4
95	-18.600	-0.11621E-01	4
96	-18.800	-0.11486E-01	4
97	-19.000	-0.11352E-01	4
98	-19.200	-0.11217E-01	4
99	-19.400	-0.11084E-01	4
100	-19.600	-0.10950E-01	4
101	-19.800	-0.10817E-01	4
102	-20.000	-0.10684E-01	4
103	-20.200	-0.10551E-01	4
104	-20.400	-0.10419E-01	4
105	-20.600	-0.10286E-01	4
106	-20.800	-0.10154E-01	4
107	-21.000	-0.10022E-01	4
108	-21.200	-0.98904E-02	4
109	-21.400	-0.97586E-02	4
110	-21.600	-0.96268E-02	4
111	-21.800	-0.94950E-02	4
112	-22.000	-0.93633E-02	4
113	-22.200	-0.10253E-01	4
114	-22.400	-0.10238E-01	4
115	-22.600	-0.10223E-01	4
116	-22.800	-0.10208E-01	4
117	-23.000	-0.10194E-01	4
118	-23.200	-0.10179E-01	4
119	-23.400	-0.10164E-01	4
120	-23.600	-0.10150E-01	4
121	-23.800	-0.10135E-01	4
122	-24.000	-0.10121E-01	4
123	-24.200	-0.10106E-01	4
124	-24.400	-0.10092E-01	4
125	-24.600	-0.10078E-01	4
126	-24.800	-0.10064E-01	4
127	-25.000	-0.10050E-01	4
128	-25.200	-0.10036E-01	4
129	-25.400	-0.10022E-01	4
130	-25.600	-0.10008E-01	4

PARATIE 7.00

Ce.A.S. s.r.l. - Milano

PAG. 14

15 NOVEMBRE 2011 18:05:24

History 0 - ORMENIS

NODO	QUOTA ZETA	SPOSTAMENTO MASSIMO	FASE PARETE RightWall
131	-25.800	-0.99939E-02	4
132	-26.000	-0.99801E-02	4
133	-26.200	-0.99663E-02	4
134	-26.400	-0.99526E-02	4
135	-26.600	-0.99389E-02	4
136	-26.800	-0.99253E-02	4
137	-27.000	-0.99117E-02	4
138	-27.200	-0.98981E-02	4
139	-27.400	-0.98846E-02	4
140	-27.600	-0.98712E-02	4
141	-27.800	-0.98578E-02	4
142	-28.000	-0.98444E-02	4
143	-28.200	-0.98310E-02	4
144	-28.400	-0.98177E-02	4
145	-28.600	-0.98045E-02	4
146	-28.800	-0.97912E-02	4
147	-29.000	-0.97780E-02	4
148	-29.200	-0.97648E-02	4
149	-29.400	-0.97517E-02	4
150	-29.600	-0.97386E-02	4
151	-29.800	-0.97255E-02	4
152	-30.000	-0.97125E-02	4

INVILUPPO AZIONI INTERNE NEGLI ELEMENTI DI PARETE
 (PER UNITA' DI PROFONDITA')

* PARETE RightWall GRUPPO Right_wall*

STEP 1 - 4

* I PASSI NON EQUILIBRATI SONO ESCLUSI *

Nella tabella si stampano i seguenti risultati:

MOMENTO SX = Momento che tende le fibre sulla faccia sinistra [kN*m/m]

MOMENTO DX = Momento che tende le fibre sulla faccia destra [kN*m/m]

TAGLIO = forza tagliante (valore assoluto, priva di segno)[kN/m]

BEAM EL.	ESTREMO	QUOTA	MOMENTO SX	MOMENTO DX	TAGLIO
1	A	0.	0.2619E-09	0.1019E-09	0.8257
	B	-0.2000	0.7276E-11	0.1651	0.8257
2	A	-0.2000	0.	0.1651	3.803
	B	-0.4000	0.	0.9258	3.803
3	A	-0.4000	0.	0.9258	6.678
	B	-0.5000	0.	1.594	6.678
4	A	-0.5000	0.	1.594	165.1
	B	-0.7000	31.43	0.	165.1
5	A	-0.7000	31.43	0.	159.7
	B	-0.9000	63.36	0.	159.7
6	A	-0.9000	63.36	0.	153.9
	B	-1.100	94.13	0.	153.9
7	A	-1.100	94.13	0.	147.8
	B	-1.300	123.7	0.	147.8
8	A	-1.300	123.7	0.	141.3
	B	-1.500	152.0	0.	141.3
9	A	-1.500	152.0	0.	135.0
	B	-1.700	178.9	0.	135.0
10	A	-1.700	178.9	0.	129.9
	B	-1.900	204.4	0.	129.9
11	A	-1.900	204.4	0.	124.4
	B	-2.100	228.3	0.	124.4
12	A	-2.100	228.3	0.	118.3
	B	-2.300	250.8	0.	118.3
13	A	-2.300	250.8	0.	111.5
	B	-2.500	271.6	0.	111.5
14	A	-2.500	271.6	0.	104.1
	B	-2.700	291.1	0.	104.1
15	A	-2.700	291.1	0.	95.89
	B	-2.900	310.3	0.	95.89
16	A	-2.900	310.3	0.	87.01
	B	-3.100	327.7	0.	87.01
17	A	-3.100	327.7	0.	77.42
	B	-3.300	343.2	0.	77.42

PARATIE 7.00

Ce.A.S. s.r.l. - Milano

PAG. 16

15 NOVEMBRE 2011 18:05:24

History 0 - ORMENIS

BEAM EL.	ESTREMO	QUOTA	MOMENTO SX	MOMENTO DX	TAGLIO
18	A	-3.300	343.2	0.	67.13
	B	-3.500	356.6	0.	67.13
19	A	-3.500	356.6	0.	56.12
	B	-3.700	367.8	0.	56.12
20	A	-3.700	367.8	0.	44.39
	B	-3.900	376.7	0.	44.39
21	A	-3.900	376.7	0.	35.04
	B	-4.000	380.2	0.	35.04
22	A	-4.000	380.2	0.	227.3
	B	-4.200	413.7	0.	227.3
23	A	-4.200	413.7	0.	215.6
	B	-4.400	456.8	0.	215.6
24	A	-4.400	456.8	0.	203.3
	B	-4.600	497.5	0.	203.3
25	A	-4.600	497.5	0.	190.7
	B	-4.800	535.6	0.	190.7
26	A	-4.800	535.6	0.	177.4
	B	-5.000	571.1	0.	177.4
27	A	-5.000	571.1	0.	165.1
	B	-5.200	604.1	0.	165.1
28	A	-5.200	604.1	0.	152.1
	B	-5.400	634.5	0.	152.1
29	A	-5.400	634.5	0.	138.4
	B	-5.600	662.2	0.	138.4
30	A	-5.600	662.2	0.	124.0
	B	-5.800	687.0	0.	124.0
31	A	-5.800	687.0	0.	108.9
	B	-6.000	708.8	0.	108.9
32	A	-6.000	708.8	0.	93.18
	B	-6.200	727.4	0.	93.18
33	A	-6.200	727.4	0.	76.71
	B	-6.400	742.8	0.	76.71
34	A	-6.400	742.8	0.	59.54
	B	-6.600	754.7	0.	59.54
35	A	-6.600	754.7	0.	41.82
	B	-6.800	763.0	0.	41.82
36	A	-6.800	763.0	0.	42.90
	B	-7.000	767.6	0.	42.90
37	A	-7.000	767.6	0.	43.74
	B	-7.200	768.3	0.	43.74
38	A	-7.200	768.3	0.	44.38
	B	-7.400	765.0	0.	44.38
39	A	-7.400	765.0	0.	44.81
	B	-7.600	757.6	0.	44.81
40	A	-7.600	757.6	0.	45.61
	B	-7.800	748.4	0.	45.61

PARATIE 7.00

Ce.A.S. s.r.l. - Milano

PAG. 17

15 NOVEMBRE 2011 18:05:24

History 0 - ORMENIS

BEAM EL.	ESTREMO	QUOTA	MOMENTO SX	MOMENTO DX	TAGLIO
41	A	-7.800	748.4	0.	52.24
	B	-8.000	738.0	0.	52.24
42	A	-8.000	738.0	0.	57.85
	B	-8.200	726.4	0.	57.85
43	A	-8.200	726.4	0.	62.66
	B	-8.400	713.9	0.	62.66
44	A	-8.400	713.9	0.	66.81
	B	-8.600	700.5	0.	66.81
45	A	-8.600	700.5	0.	70.39
	B	-8.800	686.5	0.	70.39
46	A	-8.800	686.5	0.	73.49
	B	-9.000	671.8	0.	73.49
47	A	-9.000	671.8	0.	76.15
	B	-9.200	656.5	0.	76.15
48	A	-9.200	656.5	0.	78.44
	B	-9.400	640.8	0.	78.44
49	A	-9.400	640.8	0.	80.39
	B	-9.600	624.8	0.	80.39
50	A	-9.600	624.8	0.	82.05
	B	-9.800	608.4	0.	82.05
51	A	-9.800	608.4	0.	83.46
	B	-10.00	591.7	0.	83.46
52	A	-10.00	591.7	0.	84.64
	B	-10.20	574.7	0.	84.64
53	A	-10.20	574.7	0.	85.63
	B	-10.40	557.6	0.	85.63
54	A	-10.40	557.6	0.	86.46
	B	-10.60	540.3	0.	86.46
55	A	-10.60	540.3	0.	87.16
	B	-10.80	522.9	0.	87.16
56	A	-10.80	522.9	0.	87.74
	B	-11.00	505.3	0.	87.74
57	A	-11.00	505.3	0.	88.24
	B	-11.20	487.7	0.	88.24
58	A	-11.20	487.7	0.	88.67
	B	-11.40	469.9	0.	88.67
59	A	-11.40	469.9	0.	89.06
	B	-11.60	452.1	0.	89.06
60	A	-11.60	452.1	0.	89.43
	B	-11.80	434.3	0.	89.43
61	A	-11.80	434.3	0.	89.79
	B	-12.00	416.3	0.	89.79
62	A	-12.00	416.3	0.	90.16
	B	-12.20	398.3	0.	90.16
63	A	-12.20	398.3	0.	90.56
	B	-12.40	380.2	0.	90.56

PARATIE 7.00

15 NOVEMBRE 2011 18:05:24

History 0 - ORMENIS

Ce.A.S. s.r.l. - Milano

PAG. 18

BEAM EL.	ESTREMO	QUOTA	MOMENTO SX	MOMENTO DX	TAGLIO
64	A	-12.40	380.2	0.	91.01
	B	-12.60	361.9	0.	91.01
65	A	-12.60	361.9	0.	91.52
	B	-12.80	343.6	0.	91.52
66	A	-12.80	343.6	0.	92.11
	B	-13.00	325.2	0.	92.11
67	A	-13.00	325.2	0.	92.78
	B	-13.20	306.7	0.	92.78
68	A	-13.20	306.7	0.	93.56
	B	-13.40	288.0	0.	93.56
69	A	-13.40	288.0	0.	94.45
	B	-13.60	269.1	0.	94.45
70	A	-13.60	269.1	0.	95.46
	B	-13.80	250.0	0.	95.46
71	A	-13.80	250.0	0.	96.61
	B	-14.00	230.6	0.	96.61
72	A	-14.00	230.6	0.	97.91
	B	-14.20	211.1	0.	97.91
73	A	-14.20	211.1	0.	99.35
	B	-14.40	191.2	0.	99.35
74	A	-14.40	191.2	0.	101.0
	B	-14.60	171.0	0.	101.0
75	A	-14.60	171.0	0.	102.7
	B	-14.80	150.5	0.	102.7
76	A	-14.80	150.5	0.	104.7
	B	-15.00	129.5	0.	104.7
77	A	-15.00	129.5	0.	96.48
	B	-15.20	110.2	0.	96.48
78	A	-15.20	110.2	0.	88.56
	B	-15.40	92.51	1.156	88.56
79	A	-15.40	92.51	1.156	80.92
	B	-15.60	76.33	6.178	80.92
80	A	-15.60	76.33	6.178	73.58
	B	-15.80	61.61	10.56	73.58
81	A	-15.80	61.61	10.56	66.54
	B	-16.00	48.31	14.35	66.54
82	A	-16.00	48.31	14.35	59.79
	B	-16.20	36.35	17.56	59.79
83	A	-16.20	36.35	17.56	53.35
	B	-16.40	25.68	20.24	53.35
84	A	-16.40	25.68	20.24	47.22
	B	-16.60	16.23	22.41	47.22
85	A	-16.60	16.23	22.41	41.40
	B	-16.80	7.953	24.11	41.40
86	A	-16.80	7.953	24.11	35.88
	B	-17.00	0.7778	25.36	35.88

PARATIE 7.00

Ce.A.S. s.r.l. - Milano

PAG. 19

15 NOVEMBRE 2011 18:05:24

History 0 - ORMENIS

BEAM EL.	ESTREMO	QUOTA	MOMENTO SX	MOMENTO DX	TAGLIO
87	A	-17.00	0.7778	25.36	30.67
	B	-17.20	0.	26.21	30.67
88	A	-17.20	0.	26.21	25.77
	B	-17.40	0.	26.68	25.77
89	A	-17.40	0.	26.68	21.18
	B	-17.60	0.	26.79	21.18
90	A	-17.60	0.	26.79	16.91
	B	-17.80	0.	26.59	16.91
91	A	-17.80	0.	26.59	12.94
	B	-18.00	0.	26.11	12.94
92	A	-18.00	0.	26.11	9.280
	B	-18.20	0.	25.36	9.280
93	A	-18.20	0.	25.36	5.929
	B	-18.40	0.	24.39	5.929
94	A	-18.40	0.	24.39	5.867
	B	-18.60	0.	24.34	5.867
95	A	-18.60	0.	24.34	6.718
	B	-18.80	0.	24.37	6.718
96	A	-18.80	0.	24.37	7.426
	B	-19.00	0.	23.91	7.426
97	A	-19.00	0.	23.91	7.991
	B	-19.20	0.	23.03	7.991
98	A	-19.20	0.	23.03	8.416
	B	-19.40	0.	21.79	8.416
99	A	-19.40	0.	21.79	8.701
	B	-19.60	0.	20.24	8.701
100	A	-19.60	0.	20.24	8.950
	B	-19.80	0.	18.45	8.950
101	A	-19.80	0.	18.45	9.860
	B	-20.00	0.	16.48	9.860
102	A	-20.00	0.	16.48	10.47
	B	-20.20	0.	14.38	10.47
103	A	-20.20	0.	14.38	10.77
	B	-20.40	0.	12.23	10.77
104	A	-20.40	0.	12.23	10.78
	B	-20.60	0.	10.07	10.78
105	A	-20.60	0.	10.07	10.48
	B	-20.80	0.	7.975	10.48
106	A	-20.80	0.	7.975	9.889
	B	-21.00	0.	5.997	9.889
107	A	-21.00	0.	5.997	8.992
	B	-21.20	0.	4.198	8.992
108	A	-21.20	0.	4.198	7.795
	B	-21.40	0.	2.639	7.795
109	A	-21.40	0.	2.639	6.298
	B	-21.60	0.	1.380	6.298

PARATIE 7.00
15 NOVEMBRE 2011 18:05:24
History 0 - ORMENIS

Ce.A.S. s.r.l. - Milano

PAG. 20

BEAM EL.	ESTREMO	QUOTA	MOMENTO SX	MOMENTO DX	TAGLIO
110	A	-21.60	0.	1.380	4.499
	B	-21.80	0.	0.4800	4.499
111	A	-21.80	0.	0.4800	2.400
	B	-22.00	0.7276E-10	0.6366E-10	2.400

PARATIE 7.00
15 NOVEMBRE 2011 18:05:24
History 0 - ORMENIS

Ce.A.S. s.r.l. - Milano

PAG. 21

FORZE NEGLI ANCORAGGI ATTIVI (PER UNITA' DI PROFONDITA')

TIRANTE	Wire01	1 PARETE RightWall	QUOTA	-0.50000
		FASE 1 FORZA	150.00	kN/m
		FASE 2 FORZA	167.81	kN/m
		FASE 3 FORZA	156.55	kN/m
		FASE 4 FORZA	189.98	kN/m
TIRANTE	Wire2	1 PARETE RightWall	QUOTA	-4.0000
		FASE 1 inattivo		
		FASE 2 inattivo		
		FASE 3 FORZA	150.00	kN/m
		FASE 4 FORZA	224.74	kN/m

INVILUPPO RISULTATI NEGLI ELEMENTI TERRENO

* PARETE RightWall GRUPPO DRight*

STEP 1 - 4

* I PASSI NON EQUILIBRATI SONO ESCLUSI *

Nella tabella si stampano i seguenti risultati:

SIGMA-H = massimo sforzo orizzontale efficace [kPa]

TAGLIO = massimo sforzo di taglio [kPa]

PR. ACQUA =massima pressione interstiziale [kPa]

GRAD. MAX =massimo gradiente idraulico

SOIL EL.	QUOTA	SIGMA-H	TAGLIO	PR. ACQUA	GRAD. MAX
1	0.	0.	0.	0.	0.
2	-0.2000	0.	0.	0.	0.
3	-0.4000	0.	0.	0.	0.
4	-0.5000	0.	0.	0.	0.
5	-0.7000	1.364	1.218	0.	0.
6	-0.9000	2.728	2.436	0.	0.
7	-1.100	4.093	3.654	0.	0.
8	-1.300	5.457	4.872	0.	0.
9	-1.500	6.821	6.089	0.	0.
10	-1.700	8.185	7.307	0.	0.
11	-1.900	10.51	8.046	0.	0.
12	-2.100	15.32	7.540	0.	0.
13	-2.300	20.11	7.043	0.	0.
14	-2.500	24.89	6.556	0.	0.
15	-2.700	29.64	6.081	0.	0.
16	-2.900	34.37	5.616	0.	0.
17	-3.100	39.07	5.164	0.	0.
18	-3.300	43.75	4.724	0.	0.
19	-3.500	48.41	4.297	0.	0.
20	-3.700	53.03	3.883	0.	0.
21	-3.900	57.64	3.482	0.	0.
22	-4.000	59.93	3.287	0.	0.
23	-4.200	64.49	2.907	2.074	0.3704E-01
24	-4.400	69.02	4.002	4.148	0.3704E-01
25	-4.600	73.52	6.004	6.222	0.3704E-01
26	-4.800	78.00	8.005	8.296	0.3704E-01
27	-5.000	82.37	19.37	10.37	0.3704E-01
28	-5.200	87.21	20.63	12.44	0.3704E-01
29	-5.400	92.02	21.78	14.52	0.3704E-01
30	-5.600	96.80	22.85	16.59	0.3704E-01
31	-5.800	101.6	23.85	18.67	0.3704E-01
32	-6.000	106.2	24.75	20.74	0.3704E-01
33	-6.200	110.8	25.61	22.81	0.3704E-01
34	-6.400	115.4	26.42	24.89	0.3704E-01
35	-6.600	120.0	27.20	26.96	0.3704E-01

PARATIE 7.00

Ce.A.S. s.r.l. - Milano

PAG. 23

15 NOVEMBRE 2011 18:05:24

History 0 - ORMENIS

SOIL EL.	QUOTA	SIGMA-H	TAGLIO	PR. ACQUA	GRAD. MAX
36	-6.800	124.5	27.94	29.04	0.3704E-01
37	-7.000	129.0	28.66	31.11	0.3704E-01
38	-7.200	133.6	29.35	33.19	0.3704E-01
39	-7.400	138.0	30.02	35.26	0.3704E-01
40	-7.600	142.5	32.80	37.33	0.1089
41	-7.800	147.0	36.59	39.41	0.1089
42	-8.000	151.4	39.11	41.48	0.1089
43	-8.200	155.8	41.10	43.56	0.1089
44	-8.400	160.2	42.79	45.63	0.1089
45	-8.600	164.6	44.27	47.70	0.1089
46	-8.800	169.0	45.60	49.78	0.1089
47	-9.000	173.3	46.81	51.85	0.1089
48	-9.200	177.6	47.92	53.93	0.1089
49	-9.400	182.0	48.95	56.00	0.1089
50	-9.600	186.3	49.91	58.07	0.1089
51	-9.800	190.6	50.81	60.15	0.1089
52	-10.00	194.8	51.66	62.22	0.1089
53	-10.20	199.1	52.45	64.30	0.1089
54	-10.40	203.4	53.21	66.37	0.1089
55	-10.60	207.6	53.92	68.44	0.1089
56	-10.80	211.9	54.59	70.52	0.1089
57	-11.00	216.1	55.24	72.59	0.1089
58	-11.20	220.3	55.85	74.67	0.1089
59	-11.40	224.5	56.43	76.74	0.1089
60	-11.60	228.8	56.98	78.81	0.1089
61	-11.80	233.0	57.51	80.89	0.1089
62	-12.00	237.2	58.01	82.96	0.1089
63	-12.20	241.3	58.49	85.04	0.1089
64	-12.40	245.5	58.95	87.11	0.1089
65	-12.60	249.7	59.39	89.19	0.1089
66	-12.80	253.9	59.81	91.26	0.1089
67	-13.00	258.0	60.22	93.33	0.1089
68	-13.20	262.2	60.61	95.41	0.1089
69	-13.40	266.4	60.98	97.48	0.1089
70	-13.60	270.5	61.34	99.56	0.1089
71	-13.80	274.7	61.68	101.6	0.1089
72	-14.00	278.8	62.01	103.7	0.1089
73	-14.20	283.0	62.33	105.8	0.1089
74	-14.40	287.1	62.64	107.9	0.1089
75	-14.60	291.3	62.94	109.9	0.1089
76	-14.80	295.4	63.24	112.0	0.1089
77	-15.00	301.6	74.35	114.1	0.1089
78	-15.20	305.7	74.53	116.1	0.1089
79	-15.40	309.8	74.70	118.2	0.1089
80	-15.60	313.9	74.86	120.3	0.1089
81	-15.80	318.0	75.02	122.4	0.1089

PARATIE 7.00

Ce.A.S. s.r.l. - Milano

PAG. 24

15 NOVEMBRE 2011 18:05:24

History 0 - ORMENIS

SOIL EL.	QUOTA	SIGMA-H	TAGLIO	PR. ACQUA	GRAD. MAX
82	-16.00	322.1	75.17	124.4	0.1089
83	-16.20	326.2	75.31	126.5	0.1089
84	-16.40	330.3	75.46	128.6	0.1089
85	-16.60	334.4	75.60	130.7	0.1089
86	-16.80	338.5	75.73	132.7	0.1089
87	-17.00	342.6	75.87	134.8	0.1089
88	-17.20	346.7	76.00	136.9	0.1089
89	-17.40	350.8	76.14	139.0	0.1089
90	-17.60	354.9	76.27	141.0	0.1089
91	-17.80	359.0	76.40	143.1	0.1089
92	-18.00	363.1	76.53	145.2	0.1089
93	-18.20	367.2	76.66	147.3	0.1089
94	-18.40	371.3	76.79	149.3	0.1089
95	-18.60	375.4	76.92	151.4	0.1089
96	-18.80	379.5	77.06	153.5	0.1089
97	-19.00	383.6	77.19	155.6	0.1089
98	-19.20	387.8	77.32	157.6	0.1089
99	-19.40	391.9	77.45	159.7	0.1089
100	-19.60	396.0	77.58	161.8	0.1089
101	-19.80	400.1	77.71	163.9	0.1089
102	-20.00	404.2	77.85	165.9	0.1089
103	-20.20	408.3	77.98	168.0	0.1089
104	-20.40	412.4	78.11	170.1	0.1089
105	-20.60	416.5	78.24	172.1	0.1089
106	-20.80	420.6	78.37	174.2	0.1089
107	-21.00	424.8	78.50	176.3	0.1089
108	-21.20	428.9	78.63	178.4	0.1089
109	-21.40	433.0	78.76	180.4	0.1089
110	-21.60	437.1	78.89	182.5	0.1089
111	-21.80	441.2	79.02	184.6	0.1089
112	-22.00	445.3	79.15	186.7	0.1089
113	-22.20	450.3	82.07	188.7	0.1089
114	-22.40	454.5	82.51	190.8	0.1089
115	-22.60	458.7	82.95	192.9	0.1089
116	-22.80	462.9	83.38	195.0	0.1089
117	-23.00	467.1	83.82	197.0	0.1089
118	-23.20	471.3	84.26	199.1	0.1089
119	-23.40	475.5	84.70	201.2	0.1089
120	-23.60	479.7	85.13	203.3	0.1089
121	-23.80	483.9	85.57	205.3	0.1089
122	-24.00	488.1	86.01	207.4	0.1089
123	-24.20	492.3	86.44	209.5	0.1089
124	-24.40	496.5	86.88	211.6	0.1089
125	-24.60	500.7	87.32	213.6	0.1089
126	-24.80	504.9	87.75	215.7	0.1089
127	-25.00	509.1	88.19	217.8	0.1089

PARATIE 7.00

Ce.A.S. s.r.l. - Milano

PAG. 25

15 NOVEMBRE 2011 18:05:24

History 0 - ORMENIS

SOIL EL.	QUOTA	SIGMA-H	TAGLIO	PR. ACQUA	GRAD. MAX
128	-25.20	513.3	88.62	219.9	0.1089
129	-25.40	517.5	89.06	221.9	0.1089
130	-25.60	521.7	89.49	224.0	0.1089
131	-25.80	525.9	89.93	226.1	0.1089
132	-26.00	530.1	90.36	228.1	0.1089
133	-26.20	534.3	90.79	230.2	0.1089
134	-26.40	538.5	91.23	232.3	0.1089
135	-26.60	542.7	91.66	234.4	0.1089
136	-26.80	546.9	92.09	236.4	0.1089
137	-27.00	551.1	92.53	238.5	0.1089
138	-27.20	555.3	92.96	240.6	0.1089
139	-27.40	559.5	93.39	242.7	0.1089
140	-27.60	563.7	93.83	244.7	0.1089
141	-27.80	567.9	94.26	246.8	0.1089
142	-28.00	572.1	94.69	248.9	0.1089
143	-28.20	576.3	95.12	251.0	0.1089
144	-28.40	580.5	95.56	253.0	0.1089
145	-28.60	584.7	95.99	255.1	0.1089
146	-28.80	588.9	96.42	257.2	0.1089
147	-29.00	593.1	96.85	259.3	0.1089
148	-29.20	597.3	97.28	261.3	0.1089
149	-29.40	601.5	97.72	263.4	0.1089
150	-29.60	605.7	98.15	265.5	0.1089
151	-29.80	609.9	98.58	267.6	0.1089
152	-30.00	614.1	99.01	269.6	0.1089

INVILUPPO RISULTATI NEGLI ELEMENTI TERRENO

* PARETE RightWall GRUPPO UHRight*

STEP 1 - 4

* I PASSI NON EQUILIBRATI SONO ESCLUSI *

Nella tabella si stampano i seguenti risultati:

SIGMA-H = massimo sforzo orizzontale efficace [kPa]

TAGLIO = massimo sforzo di taglio [kPa]

PR. ACQUA =massima pressione interstiziale [kPa]

GRAD. MAX =massimo gradiente idraulico

SOIL EL.	QUOTA	SIGMA-H	TAGLIO	PR. ACQUA	GRAD. MAX
1	0.	8.257	7.372	0.	0.
2	-0.2000	14.89	5.956	0.	0.
3	-0.4000	25.22	8.812	0.	0.
4	-0.5000	31.53	11.02	0.	0.
5	-0.7000	34.94	10.82	0.	0.
6	-0.9000	37.70	10.30	0.	0.
7	-1.100	40.46	9.782	0.	0.
8	-1.300	43.23	9.267	0.	0.
9	-1.500	46.01	8.809	0.	0.
10	-1.700	48.81	9.861	0.	0.
11	-1.900	51.61	10.90	0.	0.
12	-2.100	54.44	11.94	0.9630	0.1089
13	-2.300	57.28	12.96	2.889	0.1089
14	-2.500	60.14	13.97	4.815	0.1089
15	-2.700	63.03	14.96	6.741	0.1089
16	-2.900	65.93	15.94	8.667	0.1089
17	-3.100	68.86	16.91	10.59	0.1089
18	-3.300	71.81	17.86	12.52	0.1089
19	-3.500	74.79	18.79	14.44	0.1089
20	-3.700	77.79	19.71	16.37	0.1089
21	-3.900	80.81	20.61	18.30	0.1089
22	-4.000	82.34	21.06	19.26	0.1089
23	-4.200	85.41	21.93	21.19	0.1089
24	-4.400	88.50	22.79	23.11	0.1089
25	-4.600	91.62	23.58	25.04	0.1089
26	-4.800	94.77	23.95	26.96	0.1089
27	-5.000	98.46	28.11	28.89	0.1089
28	-5.200	102.0	28.56	30.81	0.1089
29	-5.400	105.5	28.98	32.74	0.1089
30	-5.600	109.0	29.38	34.67	0.1089
31	-5.800	112.6	29.75	36.59	0.1089
32	-6.000	116.2	30.09	38.52	0.1089
33	-6.200	119.8	30.43	40.44	0.1089
34	-6.400	123.4	30.77	42.37	0.1089
35	-6.600	126.9	31.07	44.30	0.1089

PARATIE 7.00

Ce.A.S. s.r.l. - Milano

PAG. 27

15 NOVEMBRE 2011 18:05:24

History 0 - ORMENIS

SOIL EL.	QUOTA	SIGMA-H	TAGLIO	PR. ACQUA	GRAD. MAX
36	-6.800	130.6	31.33	46.22	0.1089
37	-7.000	134.2	31.55	48.15	0.1089
38	-7.200	137.9	31.74	50.07	0.1089
39	-7.400	141.6	31.89	52.00	0.1089
40	-7.600	145.4	32.00	53.93	0.1089
41	-7.800	149.1	32.08	55.85	0.1089
42	-8.000	153.0	32.12	57.78	0.1089
43	-8.200	156.8	32.12	59.70	0.1089
44	-8.400	160.7	32.09	61.63	0.1089
45	-8.600	164.6	32.02	63.56	0.1089
46	-8.800	168.5	31.92	65.48	0.1089
47	-9.000	172.4	31.78	67.41	0.1089
48	-9.200	176.4	31.62	69.33	0.1089
49	-9.400	180.4	31.42	71.26	0.1089
50	-9.600	184.4	31.19	73.19	0.1089
51	-9.800	188.4	30.93	75.11	0.1089
52	-10.00	192.5	30.63	77.04	0.1089
53	-10.20	196.6	30.32	78.96	0.1089
54	-10.40	200.6	29.97	80.89	0.1089
55	-10.60	204.8	29.60	82.81	0.1089
56	-10.80	208.9	29.20	84.74	0.1089
57	-11.00	213.0	28.77	86.67	0.1089
58	-11.20	217.2	28.32	88.59	0.1089
59	-11.40	221.4	27.85	90.52	0.1089
60	-11.60	225.5	27.36	92.44	0.1089
61	-11.80	229.7	26.84	94.37	0.1089
62	-12.00	233.9	26.30	96.30	0.1089
63	-12.20	238.2	25.75	98.22	0.1089
64	-12.40	242.4	25.17	100.1	0.1089
65	-12.60	246.6	24.58	102.1	0.1089
66	-12.80	250.9	23.97	104.0	0.1089
67	-13.00	255.1	23.35	105.9	0.1089
68	-13.20	259.4	22.70	107.9	0.1089
69	-13.40	263.7	22.05	109.8	0.1089
70	-13.60	267.9	21.38	111.7	0.1089
71	-13.80	272.2	20.70	113.6	0.1089
72	-14.00	276.5	20.01	115.6	0.1089
73	-14.20	280.8	19.30	117.5	0.1089
74	-14.40	285.1	18.59	119.4	0.1089
75	-14.60	289.4	17.87	121.3	0.1089
76	-14.80	293.7	17.14	123.3	0.1089
77	-15.00	295.2	31.41	125.2	0.1089
78	-15.20	299.6	30.53	127.1	0.1089
79	-15.40	303.9	29.64	129.0	0.1089
80	-15.60	308.3	28.74	131.0	0.1089
81	-15.80	312.6	27.84	132.9	0.1089

PARATIE 7.00

Ce.A.S. s.r.l. - Milano

PAG. 28

15 NOVEMBRE 2011 18:05:24

History 0 - ORMENIS

SOIL EL.	QUOTA	SIGMA-H	TAGLIO	PR. ACQUA	GRAD. MAX
82	-16.00	317.0	26.94	134.8	0.1089
83	-16.20	321.4	26.04	136.7	0.1089
84	-16.40	325.7	25.13	138.7	0.1089
85	-16.60	330.1	24.22	140.6	0.1089
86	-16.80	334.4	23.31	142.5	0.1089
87	-17.00	338.8	22.40	144.4	0.1089
88	-17.20	343.1	21.49	146.4	0.1089
89	-17.40	347.5	20.58	148.3	0.1089
90	-17.60	351.9	19.68	150.2	0.1089
91	-17.80	356.2	18.77	152.1	0.1089
92	-18.00	360.6	17.87	154.1	0.1089
93	-18.20	364.9	16.96	156.0	0.1089
94	-18.40	369.3	16.06	157.9	0.1089
95	-18.60	373.6	15.73	159.9	0.1089
96	-18.80	378.0	16.37	161.8	0.1089
97	-19.00	382.3	17.00	163.7	0.1089
98	-19.20	386.7	17.64	165.6	0.1089
99	-19.40	391.0	18.27	167.6	0.1089
100	-19.60	395.3	18.90	169.5	0.1089
101	-19.80	399.7	19.53	171.4	0.1089
102	-20.00	404.0	20.16	173.3	0.1089
103	-20.20	408.4	20.79	175.3	0.1089
104	-20.40	412.7	21.42	177.2	0.1089
105	-20.60	417.0	22.04	179.1	0.1089
106	-20.80	421.4	22.67	181.0	0.1089
107	-21.00	425.7	23.29	183.0	0.1089
108	-21.20	430.1	23.92	184.9	0.1089
109	-21.40	434.4	24.54	186.8	0.1089
110	-21.60	438.7	25.16	188.7	0.1089
111	-21.80	443.1	25.79	190.7	0.1089
112	-22.00	447.4	26.41	192.6	0.1089
113	-22.20	450.3	24.65	194.5	0.1089
114	-22.40	454.5	25.08	196.4	0.1089
115	-22.60	458.7	25.50	198.4	0.1089
116	-22.80	462.9	25.93	200.3	0.1089
117	-23.00	467.1	26.35	202.2	0.1089
118	-23.20	471.3	26.78	204.1	0.1089
119	-23.40	475.5	27.20	206.1	0.1089
120	-23.60	479.7	27.63	208.0	0.1089
121	-23.80	483.9	28.05	209.9	0.1089
122	-24.00	488.1	28.48	211.9	0.1089
123	-24.20	492.3	28.90	213.8	0.1089
124	-24.40	496.5	29.32	215.7	0.1089
125	-24.60	500.7	29.75	217.6	0.1089
126	-24.80	504.9	30.17	219.6	0.1089
127	-25.00	509.1	30.60	221.5	0.1089

PARATIE 7.00

Ce.A.S. s.r.l. - Milano

PAG. 29

15 NOVEMBRE 2011 18:05:24

History 0 - ORMENIS

SOIL EL.	QUOTA	SIGMA-H	TAGLIO	PR. ACQUA	GRAD. MAX
128	-25.20	513.3	31.02	223.4	0.1089
129	-25.40	517.5	31.44	225.3	0.1089
130	-25.60	521.7	31.87	227.3	0.1089
131	-25.80	525.9	32.29	229.2	0.1089
132	-26.00	530.1	32.72	231.1	0.1089
133	-26.20	534.3	33.14	233.0	0.1089
134	-26.40	538.5	33.56	235.0	0.1089
135	-26.60	542.7	33.99	236.9	0.1089
136	-26.80	546.9	34.41	238.8	0.1089
137	-27.00	551.1	34.83	240.7	0.1089
138	-27.20	555.3	35.26	242.7	0.1089
139	-27.40	559.5	35.68	244.6	0.1089
140	-27.60	563.7	36.10	246.5	0.1089
141	-27.80	567.9	36.53	248.4	0.1089
142	-28.00	572.1	36.95	250.4	0.1089
143	-28.20	576.3	37.37	252.3	0.1089
144	-28.40	580.5	37.80	254.2	0.1089
145	-28.60	584.7	38.22	256.1	0.1089
146	-28.80	588.9	38.65	258.1	0.1089
147	-29.00	593.1	39.07	260.0	0.1089
148	-29.20	597.3	39.49	261.9	0.1089
149	-29.40	601.5	39.91	263.9	0.1089
150	-29.60	605.7	40.34	265.8	0.1089
151	-29.80	609.9	40.76	267.7	0.1089
152	-30.00	614.1	41.18	269.6	0.1089

RIASSUNTO SPINTE NEGLI ELEMENTI TERRENO
(LE SPINTE SONO CALCOLATE INTEGRANDO GLI SFORZI NEI SINGOLI ELEMENTI MOLLA)

SPINTA EFFICACE VERA = Integrale delle pressioni orizzontali efficaci in tutti gli elementi nel gruppo: unita' di misura kN/m

SPINTA ACQUA = Integrale delle pressioni interstiziali in tutti gli elementi nel gruppo: unita' di misura kN/m

SPINTA TOTALE VERA = Somma della SPINTA EFFICACE e della SPINTA DELL'ACQUA: e' l' azione totale sulla parete: unita' di misura kN/m

SPINTA ATTIVA POSSIBILE = La minima spinta che puo' essere esercitata da questo gruppo di elementi terreno, in questa fase: unita' di misura kN/m

SPINTA PASSIVA POSSIBILE = La massima spinta che puo' essere esercitata da questo gruppo di elementi terreno, in questa fase: unita' di misura kN/m

RAPPORTO PASSIVA/VERA = e' il rapporto tra la massima spinta possibile e la spinta efficace vera: fornisce un'indicazione su quanta spinta passiva venga mobilitata;

SPINTA PASSIVA MOBILITATA = e' l'inverso del rapporto precedente, espresso in unita' percentuale: indica quanta parte della massima spinta possibile e' stata mobilitata;

RAPPORTO VERA/ATTIVA = e' il rapporto tra la spinta efficace vera e la minima spinta possibile: fornisce un'indicazione di quanto questa porzione di terreno sia prossima alla condizione di massimo rilascio.

FASE	1	GRUPPO -->	DHRi	UHRi
SPINTA EFFICACE VERA			8943.6	9082.2
SPINTA ACQUA			0.	0.
SPINTA TOTALE VERA			8943.6	9082.2
SPINTA ATTIVA (POSSIBILE)			1921.3	2012.7
SPINTA PASSIVA (POSSIBILE)			38013.	39097.
RAPPORTO PASSIVA/VERA			4.2504	4.3048
SPINTA PASSIVA MOBILITATA			24.%	23.%
RAPPORTO VERA/ATTIVA			4.6551	4.5124

PARATIE 7.00
15 NOVEMBRE 2011 18:05:24
History 0 - ORMENIS

Ce.A.S. s.r.l. - Milano

PAG. 31

FASE	2	GRUPPO -->	DHRi	UHRi
		SPINTA EFFICACE VERA	6182.7	6068.0
		SPINTA ACQUA	3505.2	3774.9
		SPINTA TOTALE VERA	9687.8	9842.9
		SPINTA ATTIVA (POSSIBILE)	289.51	814.88
		SPINTA PASSIVA (POSSIBILE)	17101.	24290.
		RAPPORTO PASSIVA/VERA	2.7660	4.0030
		SPINTA PASSIVA MOBILITATA	36.%	25.%
		RAPPORTO VERA/ATTIVA	21.356	7.4466

FASE	3	GRUPPO -->	DHRi	UHRi
		SPINTA EFFICACE VERA	6149.7	6163.3
		SPINTA ACQUA	3505.2	3774.9
		SPINTA TOTALE VERA	9654.9	9938.1
		SPINTA ATTIVA (POSSIBILE)	289.51	814.88
		SPINTA PASSIVA (POSSIBILE)	17101.	24290.
		RAPPORTO PASSIVA/VERA	2.7808	3.9411
		SPINTA PASSIVA MOBILITATA	36.%	25.%
		RAPPORTO VERA/ATTIVA	21.242	7.5635

FASE	4	GRUPPO -->	DHRi	UHRi
		SPINTA EFFICACE VERA	5839.2	5536.3
		SPINTA ACQUA	2807.0	3493.1
		SPINTA TOTALE VERA	8646.2	9029.4
		SPINTA ATTIVA (POSSIBILE)	104.78	1127.3
		SPINTA PASSIVA (POSSIBILE)	12838.	28038.
		RAPPORTO PASSIVA/VERA	2.1986	5.0643
		SPINTA PASSIVA MOBILITATA	45.%	20.%
		RAPPORTO VERA/ATTIVA	55.731	4.9112

OUTPUT PLOTS:

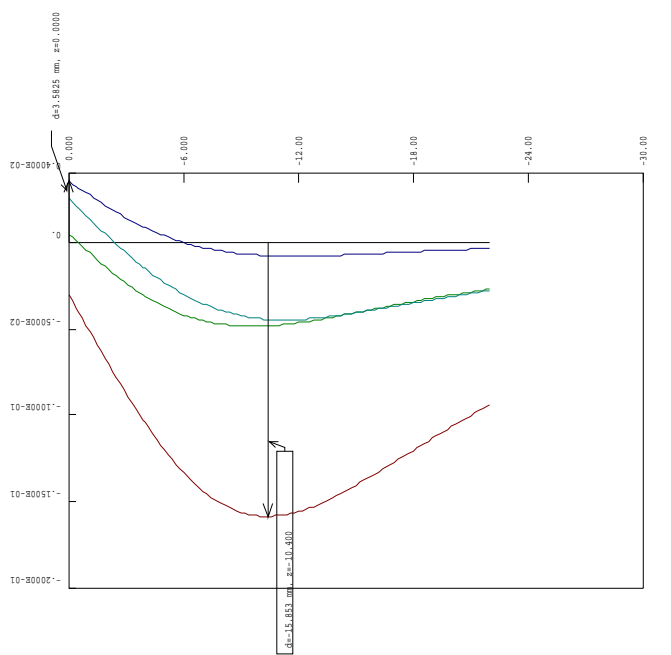

FATTORE SCALA: 2.46 - FATTORE AMPLIF.: 848.33
DEFORMATA PASSI 1 / 4 [m]

LIB: C:\Mira\A1\Tecnica\Bambini\..._11\Bella_Bambini_Omnis.fem...omni\ACTE_A1\B1E1_T0m_HZP01

Piece units= mm
Length units= m

* Ce.A.S. S.r.l. Milano *
www.ceas.it
P A R T I E 7.00

15 NOVEMBRE 2011 18:05:24

Step 4
Step 3
Step 2
Step 1

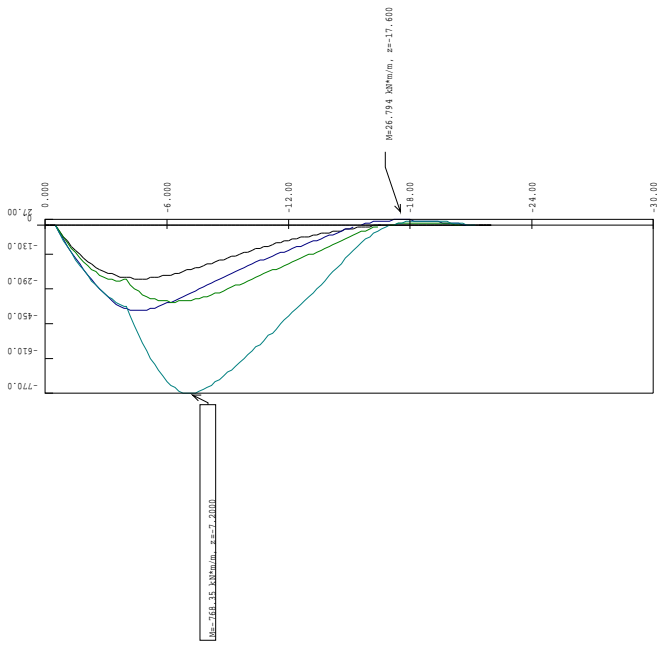

MOMENTI FLETTENTI [kN*m/m]
INVILUPPO DA 1 A 4 SCALA GEOM. : 2,32

Perce unitas KN
Length unitas M

* Ce.A.S. S.r.l. Milano *
www.ceas.it
P A R A T I E 7.00

15 NOVEMBRE 2011 18:05:24

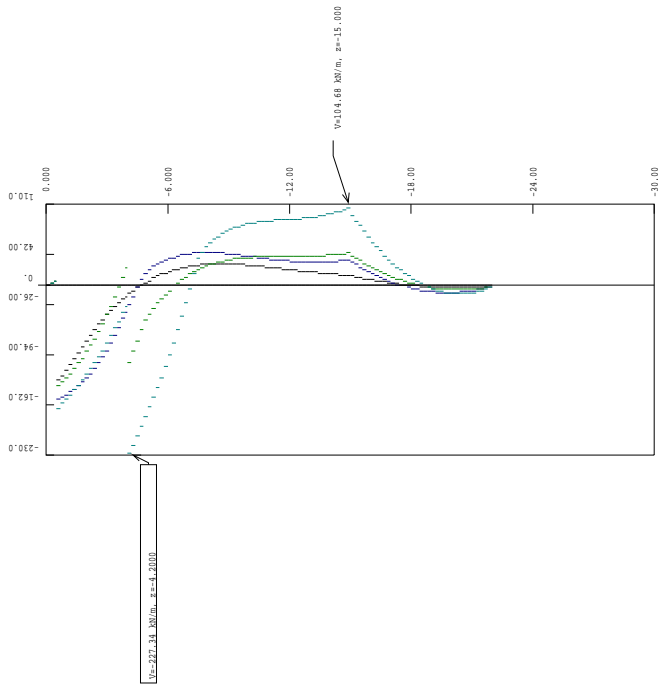

Step 4
Step 3
Step 2
Step 1

TAGLI [KN/m]
INVILUPPO DA 1 A 4 SCALA GEOM. : 2,32

URB... C:\Users\A\Documents\A\Barkolop\Biom..._controlla..._111\Bella_Barkolop\omnis..._data..._omnis\A\Barkolop\Biom..._125m_142200

Pezzo unitas KN
Length unitas M

* Ce.A.S. S.r.l. Milano *
www.ceas.it
P A R A T I E 7.00
15 NOVEMBRE 2011 18:05:24

STEP	FORCE [KN/m]
1.	150.
2.	167.8
3.	156.5
4.	190.0

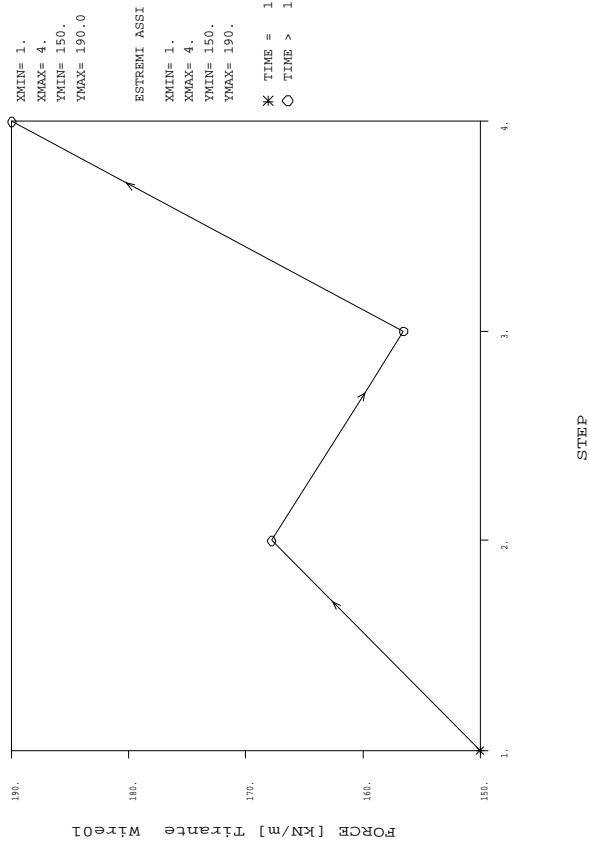

DAL PASSO 1 AL PASSO 4
 DIAGRAMMA VARIABILE X / VARIABILE Y

PIRELLA
 GRUPPO

FILE: C:\Users\A... \AppData\Local\Temp\142200...

Force units= KN
 Length units= M

* Ce.A.S. S.r.l. Milano *
 www.ceas.it
 P A R A T I E 7.00
 15 NOVEMBRE 2011 18:05:24

Tirante_Wire2 STEP	FORCE [KN/m]
1.	0.
2.	0.
3.	150.
4.	224.7

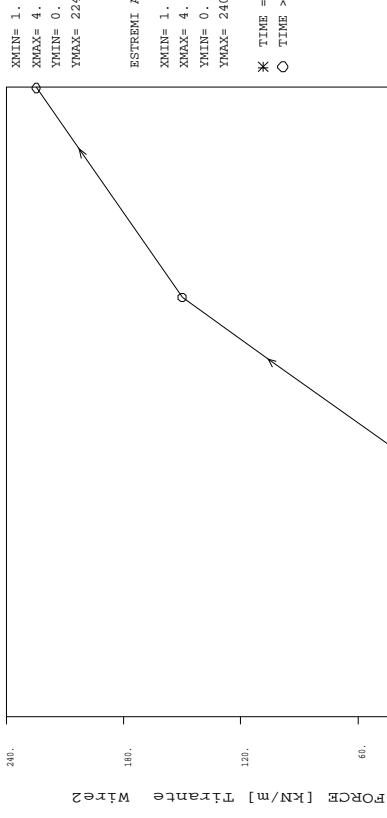

DAL PASSO 1 AL PASSO 4
DIAGRAMMA VARIABILE X / VARIABILE Y

* Ce.A.S. S.r.l. Milano *
 www.ceas.it
 P A R A T I E 7.00
 15 NOVEMBRE 2011 18:05:24

Force unitas KN
 Length unitas M

URI: c:\Users\alec\Documents\...
 Hierarchy 0 - OMENIS

PARATIE 7.00
15 NOVEMBRE 2011 18:05:45
History 0 - ORMENIS

Ce.A.S. s.r.l. - Milano

PAG. 1

```
*****  
**  
**          P  A  R  A  T  I  E          **  
**  
**          RELEASE 7.00  VERSIONE WIN  **  
**  
**  Ce.A.S. s.r.l. - Viale Giustiniano, 10  **  
**                      20129 MILANO      **  
**  
*****
```

JOBNAME C:\Users\Tecnico5\Desktop\Nuova cartella (3)\File Paratie Ormenis L

15 NOVEMBRE 2011 18:05:45

ELENCO DEI DATI DI INPUT(PARAGEN)

Per il significato dei vari comandi
si faccia riferimento al manuale di
input PARAGEN, versione 7.00.

N. comando

```
1: * Paratie for Windows version 7.0
2: * Filename= <c:\users\tecnico5\desktop\nuova cartella (3)\file paratie
  ormenis 1
3: * project with "run time" parameters
4: * Force=kN Lenght=m
5: *
6: units m kN
7: title History 0 - ORMENIS
8: delta 0.2
9: option param itemax 20
10: option noprint echo
11: option noprint displ
12: option noprint react
13: option noprint stresses
14:   wall RightWall 0 -30 0
15: *
16: soil DHRight RightWall -30 0 2 0
17: soil UHRight RightWall -30 0 1 180
18: *
19: material Pali 3.2308E+007
20: material Acciaio 2.1E+008
21: *
22: beam Right_wall RightWall -25 0 Pali 0.979439 00 00
23: *
24: wire Wire01 RightWall -0.5 Acciaio 2.87179E-005 150 157.5
25: wire Wire2 RightWall -4 Acciaio 4.30769E-005 150 157.5
26: wire Wire3 RightWall -8 Acciaio 4.30769E-005 300 157.5
27: *
28: * Soil Profile
29: *
30:   ldata           Soil 0
31:     weight        19 9 10
32:     atrest        1 0.5 1
33:     resistance    0 25 0.359 3.319
34:     young         18000 23000
35:   endlayer
36:   ldata           Soil2 -5
37:     weight        21 11 10
38:     atrest        1 0.5 1
```

PARATIE 7.00
15 NOVEMBRE 2011 18:05:45
History 0 - ORMENIS

Ce.A.S. s.r.l. - Milano

PAG. 3

N. comando

```
39:      resistance 20 28 0.317 3.929
40:      young      20000 25000
41:      endlayer
42:      ldata      Soil3 -15
43:      weight     21 11 10
44:      atrest     1 0.5 1
45:      resistance 40 28 0.317 3.929
46:      young      30000 35000
47:      endlayer
48: *
49: step 1 :
50:      setwall RightWall
51:      geom 0 -0.5
52:      add Wire01
53: endstep
54: *
55: step 2 :
56:      setwall RightWall
57:      geom 0 -4
58:      water -2 2
59: endstep
60: *
61: step 3 :
62:      setwall RightWall
63:      add Wire2
64: endstep
65: *
66: step 4 :
67:      setwall RightWall
68:      geom 0 -8.5
69:      water -2 6.5
70: endstep
71: *
72: step 5 :
73:      setwall RightWall
74:      add Wire3
75: endstep
76: *
77: step 6 :
78:      setwall RightWall
79:      geom 0 -9.5
80:      water -2 7.5
81:      surcharge 23 0 0 0
82: endstep
83: *
84: *
```

RIASSUNTO PARAMETRI GEOTECNICI PER LA FASE 1

LAYER Soil			
natura 1=granulare, 2=argilla	=	1.0000	
quota superiore	=	0.0000	m
quota inferiore	=	-5.0000	m
peso fuori falda	=	19.000	kN/m ³
peso efficace in falda	=	9.0000	kN/m ³
peso dell'acqua	=	10.000	kN/m ³
angolo di attrito	=	25.000	DEG (A MONTE)
coeff. spinta attiva ka	=	0.35900	(A MONTE)
coeff. spinta passiva kp	=	3.3190	(A MONTE)
Konc normal consolidato	=	1.0000	
esponente di OCR	=	0.50000	
OCR: grado di sovraconsolidazione	=	1.0000	
modello di rigidezza	=	1.0000	
modulo el. compr. vergine	=	18000.	kPa
modulo el. scarico/ricarico	=	23000.	kPa
natura 1=granulare, 2=argilla	=	1.0000	(A VALLE)
angolo di attrito	=	25.000	DEG (A VALLE)
coeff. spinta attiva ka	=	0.35900	(A VALLE)
coeff. spinta passiva kp	=	3.3190	(A VALLE)
LAYER Soil2			
natura 1=granulare, 2=argilla	=	1.0000	
quota superiore	=	-5.0000	m
quota inferiore	=	-15.000	m
peso fuori falda	=	21.000	kN/m ³
peso efficace in falda	=	11.000	kN/m ³
peso dell'acqua	=	10.000	kN/m ³
coesione	=	20.000	kPa (A MONTE)
angolo di attrito	=	28.000	DEG (A MONTE)
coeff. spinta attiva ka	=	0.31700	(A MONTE)
coeff. spinta passiva kp	=	3.9290	(A MONTE)
Konc normal consolidato	=	1.0000	
esponente di OCR	=	0.50000	
OCR: grado di sovraconsolidazione	=	1.0000	
modello di rigidezza	=	1.0000	
modulo el. compr. vergine	=	20000.	kPa
modulo el. scarico/ricarico	=	25000.	kPa
natura 1=granulare, 2=argilla	=	1.0000	(A VALLE)
coesione	=	20.000	kPa (A VALLE)
angolo di attrito	=	28.000	DEG (A VALLE)
coeff. spinta attiva ka	=	0.31700	(A VALLE)

RIASSUNTO PARAMETRI GEOTECNICI PER LA FASE 1

coeff. spinta passiva kp = 3.9290 (A VALLE)

LAYER Soil3

natura 1=granulare, 2=argilla = 1.0000
quota superiore = -15.000 m
quota inferiore = -0.10000E+31 m
peso fuori falda = 21.000 kN/m³
peso efficace in falda = 11.000 kN/m³
peso dell'acqua = 10.000 kN/m³
coesione = 40.000 kPa (A MONTE)
angolo di attrito = 28.000 DEG (A MONTE)
coeff. spinta attiva ka = 0.31700 (A MONTE)
coeff. spinta passiva kp = 3.9290 (A MONTE)
Konc normal consolidato = 1.0000
esponente di OCR = 0.50000
OCR: grado di sovraconsolidazione = 1.0000
modello di rigidezza = 1.0000
modulo el. compr. vergine = 30000. kPa
modulo el. scarico/ricarico = 35000. kPa
natura 1=granulare, 2=argilla = 1.0000 (A VALLE)
coesione = 40.000 kPa (A VALLE)
angolo di attrito = 28.000 DEG (A VALLE)
coeff. spinta attiva ka = 0.31700 (A VALLE)
coeff. spinta passiva kp = 3.9290 (A VALLE)

RIASSUNTO PARAMETRI GEOTECNICI PER LA FASE 2

(SOLO I PARAMETRI CHE POSSONO VARIARE)

NESSUN CAMBIAMENTO RISPETTO AL PASSO PRECEDENTE

RIASSUNTO PARAMETRI GEOTECNICI PER LA FASE 3

(SOLO I PARAMETRI CHE POSSONO VARIARE)

NESSUN CAMBIAMENTO RISPETTO AL PASSO PRECEDENTE

RIASSUNTO PARAMETRI GEOTECNICI PER LA FASE 4

(SOLO I PARAMETRI CHE POSSONO VARIARE)

NESSUN CAMBIAMENTO RISPETTO AL PASSO PRECEDENTE

RIASSUNTO PARAMETRI GEOTECNICI PER LA FASE 5

(SOLO I PARAMETRI CHE POSSONO VARIARE)

PARATIE 7.00
15 NOVEMBRE 2011 18:05:45
History 0 - ORMENIS

Ce.A.S. s.r.l. - Milano

PAG. 6

NESSUN CAMBIAMENTO RISPETTO AL PASSO PRECEDENTE

RIASSUNTO PARAMETRI GEOTECNICI PER LA FASE 6

(SOLO I PARAMETRI CHE POSSONO VARIARE)

NESSUN CAMBIAMENTO RISPETTO AL PASSO PRECEDENTE

RIASSUNTO DATI RELATIVI ALLA FASE 1

WALL RightWall

coordinata y	=	0.0000	m
quota piano campagna	=	0.0000	m
quota del fondo scavo	=	-0.50000	m
quota della falda	=	-0.99900E+30	m
sovraccarico a monte	=	0.0000	kPa
quota del sovraccarico a monte	=	0.0000	m
depressione falda a valle	=	0.0000	m
sovraccarico a valle	=	0.0000	kPa
quota del sovraccarico a valle	=	-0.99900E+30	m
quota di taglio	=	0.0000	m
quota di equil. pressioni dell'acqua	=	-30.000	m
indicatore comportamento acqua	=	0.0000	(1=REMOVE)
opzione aggiornamento pressioni acqua	=	0.0000	(1=NO UPD)

RIASSUNTO DATI RELATIVI ALLA FASE 2

WALL RightWall

coordinata y	=	0.0000	m
quota piano campagna	=	0.0000	m
quota del fondo scavo	=	-4.0000	m
quota della falda	=	-2.0000	m
sovraccarico a monte	=	0.0000	kPa
quota del sovraccarico a monte	=	0.0000	m
depressione falda a valle	=	2.0000	m
sovraccarico a valle	=	0.0000	kPa
quota del sovraccarico a valle	=	-0.99900E+30	m
quota di taglio	=	0.0000	m
quota di equil. pressioni dell'acqua	=	-30.000	m
indicatore comportamento acqua	=	0.0000	(1=REMOVE)
opzione aggiornamento pressioni acqua	=	0.0000	(1=NO UPD)

RIASSUNTO DATI RELATIVI ALLA FASE 3

WALL RightWall

coordinata y	=	0.0000	m
quota piano campagna	=	0.0000	m
quota del fondo scavo	=	-4.0000	m
quota della falda	=	-2.0000	m
sovraccarico a monte	=	0.0000	kPa

15 NOVEMBRE 2011 18:05:45

History 0 - ORMENIS

RIASSUNTO DATI RELATIVI ALLA FASE 3

quota del sovraccarico a monte	=	0.0000	m
depressione falda a valle	=	2.0000	m
sovraccarico a valle	=	0.0000	kPa
quota del sovraccarico a valle	=	-0.99900E+30	m
quota di taglio	=	0.0000	m
quota di equil. pressioni dell'acqua	=	-30.0000	m
indicatore comportamento acqua	=	0.0000	(1=REMOVE)
opzione aggiornamento pressioni acqua	=	0.0000	(1=NO UPD)

RIASSUNTO DATI RELATIVI ALLA FASE 4

WALL RightWall

coordinata y	=	0.0000	m
quota piano campagna	=	0.0000	m
quota del fondo scavo	=	-8.5000	m
quota della falda	=	-2.0000	m
sovraccarico a monte	=	0.0000	kPa
quota del sovraccarico a monte	=	0.0000	m
depressione falda a valle	=	6.5000	m
sovraccarico a valle	=	0.0000	kPa
quota del sovraccarico a valle	=	-0.99900E+30	m
quota di taglio	=	0.0000	m
quota di equil. pressioni dell'acqua	=	-30.0000	m
indicatore comportamento acqua	=	0.0000	(1=REMOVE)
opzione aggiornamento pressioni acqua	=	0.0000	(1=NO UPD)

RIASSUNTO DATI RELATIVI ALLA FASE 5

WALL RightWall

coordinata y	=	0.0000	m
quota piano campagna	=	0.0000	m
quota del fondo scavo	=	-8.5000	m
quota della falda	=	-2.0000	m
sovraccarico a monte	=	0.0000	kPa
quota del sovraccarico a monte	=	0.0000	m
depressione falda a valle	=	6.5000	m
sovraccarico a valle	=	0.0000	kPa
quota del sovraccarico a valle	=	-0.99900E+30	m
quota di taglio	=	0.0000	m
quota di equil. pressioni dell'acqua	=	-30.0000	m
indicatore comportamento acqua	=	0.0000	(1=REMOVE)
opzione aggiornamento pressioni acqua	=	0.0000	(1=NO UPD)

RIASSUNTO DATI RELATIVI ALLA FASE 6

PARATIE 7.00
15 NOVEMBRE 2011 18:05:45
History 0 - ORMENIS

Ce.A.S. s.r.l. - Milano

PAG. 9

WALL RightWall

coordinata y	=	0.0000	m
quota piano campagna	=	0.0000	m
quota del fondo scavo	=	-9.5000	m
quota della falda	=	-2.0000	m
sovraccarico a monte	=	23.000	kPa
quota del sovraccarico a monte	=	0.0000	m
depressione falda a valle	=	7.5000	m
sovraccarico a valle	=	0.0000	kPa
quota del sovraccarico a valle	=	0.0000	m
quota di taglio	=	0.0000	m
quota di equil. pressioni dell'acqua	=	-30.000	m
indicatore comportamento acqua	=	0.0000	(1=REMOVE)
opzione aggiornamento pressioni acqua	=	0.0000	(1=NO UPD)

RIASSUNTO ELEMENTI
 =====

RIASSUNTO ELEMENTI SOIL						
Name	Wall	Z1	Z2	Flag	Angle	
		m	m		deg	
DHRight	RightWall	0.	-30.00	DOWNHILL	0.	
UHRight	RightWall	0.	-30.00	UPHILL	180.0	

RIASSUNTO ELEMENTI BEAM						
Name	Wall	Z1	Z2	Mat	thick	
		m	m		m	
Right_wall	RightWall	0.	-25.00	_	0.9794	

RIASSUNTO ELEMENTI WIRE						
Name	Wall	Zeta	Mat	A/L	Pinit	Angle
		m			kN/m	deg
Wire01	RightWall	-.5000	_	0.2872E-04	150.0	157.5
Wire2	RightWall	-4.000	_	0.4308E-04	150.0	157.5
Wire3	RightWall	-8.000	_	0.4308E-04	300.0	157.5

PARATIE 7.00
15 NOVEMBRE 2011 18:05:45
History 0 - ORMENIS

Ce.A.S. s.r.l. - Milano

PAG. 11

RIASSUNTO DATI VARI
=====

MATERIALI	
Name	YOUNG MODULUS
	kPa
Pali	3.2308E+007
Acci	2.1E+008

PARATIE 7.00

Ce.A.S. s.r.l. - Milano

PAG. 12

15 NOVEMBRE 2011 18:05:45

History 0 - ORMENIS

RIASSUNTO ANALISI INCREMENTALE

FASE	N. DI ITERAZIONI	CONVERGENZA
1	3	SI
2	3	SI
3	3	SI
4	2	SI
5	2	SI
6	2	SI

MASSIMI SPOSTAMENTI LATERALI

TUTTI I PASSI

* PARETE RightWall*

* I PASSI NON EQUILIBRATI SONO ESCLUSI *

* NOTA: LE QUOTE ESPRESSE IN m

E GLI SPOSTAMENTI IN m

NODO	QUOTA ZETA	SPOSTAMENTO MASSIMO	FASE	PARETE RightWall
1	0.0000	0.35788E-02	1	
2	-0.20000	0.34309E-02	1	
3	-0.40000	0.32831E-02	1	
4	-0.50000	0.32091E-02	1	
5	-0.70000	-0.35303E-02	6	
6	-0.90000	-0.40153E-02	6	
7	-1.1000	-0.44993E-02	6	
8	-1.3000	-0.49820E-02	6	
9	-1.5000	-0.54629E-02	6	
10	-1.7000	-0.59416E-02	6	
11	-1.9000	-0.64177E-02	6	
12	-2.1000	-0.68908E-02	6	
13	-2.3000	-0.73607E-02	6	
14	-2.5000	-0.78270E-02	6	
15	-2.7000	-0.82894E-02	6	
16	-2.9000	-0.87478E-02	6	
17	-3.1000	-0.92020E-02	6	
18	-3.3000	-0.96516E-02	6	
19	-3.5000	-0.10097E-01	6	
20	-3.7000	-0.10537E-01	6	
21	-3.9000	-0.10973E-01	6	
22	-4.0000	-0.11189E-01	6	
23	-4.2000	-0.11617E-01	6	
24	-4.4000	-0.12039E-01	6	
25	-4.6000	-0.12456E-01	6	
26	-4.8000	-0.12866E-01	6	
27	-5.0000	-0.13269E-01	6	
28	-5.2000	-0.13664E-01	6	
29	-5.4000	-0.14050E-01	6	
30	-5.6000	-0.14429E-01	6	
31	-5.8000	-0.14798E-01	6	
32	-6.0000	-0.15158E-01	6	
33	-6.2000	-0.15508E-01	6	
34	-6.4000	-0.15849E-01	6	
35	-6.6000	-0.16180E-01	6	
36	-6.8000	-0.16501E-01	6	
37	-7.0000	-0.16811E-01	6	
38	-7.2000	-0.17112E-01	6	

15 NOVEMBRE 2011 18:05:45

History 0 - ORMENIS

NODO	QUOTA ZETA	SPOSTAMENTO MASSIMO	FASE PARETE RightWall
39	-7.4000	-0.17402E-01	6
40	-7.6000	-0.17682E-01	6
41	-7.8000	-0.17953E-01	6
42	-8.0000	-0.18214E-01	6
43	-8.2000	-0.18466E-01	6
44	-8.4000	-0.18707E-01	6
45	-8.6000	-0.18939E-01	6
46	-8.8000	-0.19159E-01	6
47	-9.0000	-0.19368E-01	6
48	-9.2000	-0.19566E-01	6
49	-9.4000	-0.19751E-01	6
50	-9.6000	-0.19925E-01	6
51	-9.8000	-0.20087E-01	6
52	-10.000	-0.20236E-01	6
53	-10.200	-0.20374E-01	6
54	-10.400	-0.20499E-01	6
55	-10.600	-0.20612E-01	6
56	-10.800	-0.20714E-01	6
57	-11.000	-0.20804E-01	6
58	-11.200	-0.20882E-01	6
59	-11.400	-0.20949E-01	6
60	-11.600	-0.21004E-01	6
61	-11.800	-0.21049E-01	6
62	-12.000	-0.21082E-01	6
63	-12.200	-0.21106E-01	6
64	-12.400	-0.21118E-01	6
65	-12.600	-0.21121E-01	6
66	-12.800	-0.21115E-01	6
67	-13.000	-0.21099E-01	6
68	-13.200	-0.21074E-01	6
69	-13.400	-0.21040E-01	6
70	-13.600	-0.20998E-01	6
71	-13.800	-0.20948E-01	6
72	-14.000	-0.20890E-01	6
73	-14.200	-0.20825E-01	6
74	-14.400	-0.20754E-01	6
75	-14.600	-0.20676E-01	6
76	-14.800	-0.20593E-01	6
77	-15.000	-0.20504E-01	6
78	-15.200	-0.20410E-01	6
79	-15.400	-0.20312E-01	6
80	-15.600	-0.20209E-01	6
81	-15.800	-0.20103E-01	6
82	-16.000	-0.19994E-01	6
83	-16.200	-0.19882E-01	6
84	-16.400	-0.19768E-01	6

15 NOVEMBRE 2011 18:05:45

History 0 - ORMENIS

NODO	QUOTA ZETA	SPOSTAMENTO MASSIMO	FASE PARETE RightWall
85	-16.600	-0.19651E-01	6
86	-16.800	-0.19532E-01	6
87	-17.000	-0.19412E-01	6
88	-17.200	-0.19290E-01	6
89	-17.400	-0.19167E-01	6
90	-17.600	-0.19043E-01	6
91	-17.800	-0.18919E-01	6
92	-18.000	-0.18793E-01	6
93	-18.200	-0.18668E-01	6
94	-18.400	-0.18542E-01	6
95	-18.600	-0.18416E-01	6
96	-18.800	-0.18290E-01	6
97	-19.000	-0.18164E-01	6
98	-19.200	-0.18038E-01	6
99	-19.400	-0.17913E-01	6
100	-19.600	-0.17788E-01	6
101	-19.800	-0.17663E-01	6
102	-20.000	-0.17538E-01	6
103	-20.200	-0.17414E-01	6
104	-20.400	-0.17291E-01	6
105	-20.600	-0.17168E-01	6
106	-20.800	-0.17046E-01	6
107	-21.000	-0.16924E-01	6
108	-21.200	-0.16803E-01	6
109	-21.400	-0.16682E-01	6
110	-21.600	-0.16561E-01	6
111	-21.800	-0.16441E-01	6
112	-22.000	-0.16322E-01	6
113	-22.200	-0.16203E-01	6
114	-22.400	-0.16084E-01	6
115	-22.600	-0.15966E-01	6
116	-22.800	-0.15848E-01	6
117	-23.000	-0.15730E-01	6
118	-23.200	-0.15613E-01	6
119	-23.400	-0.15495E-01	6
120	-23.600	-0.15378E-01	6
121	-23.800	-0.15261E-01	6
122	-24.000	-0.15145E-01	6
123	-24.200	-0.15028E-01	6
124	-24.400	-0.14911E-01	6
125	-24.600	-0.14794E-01	6
126	-24.800	-0.14678E-01	6
127	-25.000	-0.14561E-01	6
128	-25.200	-0.15347E-01	6
129	-25.400	-0.15321E-01	6
130	-25.600	-0.15296E-01	6

PARATIE 7.00

Ce.A.S. s.r.l. - Milano

PAG. 16

15 NOVEMBRE 2011 18:05:45

History 0 - ORMENIS

NODO	QUOTA ZETA	SPOSTAMENTO MASSIMO	FASE PARETE RightWall
131	-25.800	-0.15270E-01	6
132	-26.000	-0.15245E-01	6
133	-26.200	-0.15219E-01	6
134	-26.400	-0.15194E-01	6
135	-26.600	-0.15169E-01	6
136	-26.800	-0.15144E-01	6
137	-27.000	-0.15119E-01	6
138	-27.200	-0.15095E-01	6
139	-27.400	-0.15070E-01	6
140	-27.600	-0.15045E-01	6
141	-27.800	-0.15021E-01	6
142	-28.000	-0.14997E-01	6
143	-28.200	-0.14972E-01	6
144	-28.400	-0.14948E-01	6
145	-28.600	-0.14924E-01	6
146	-28.800	-0.14900E-01	6
147	-29.000	-0.14876E-01	6
148	-29.200	-0.14853E-01	6
149	-29.400	-0.14829E-01	6
150	-29.600	-0.14805E-01	6
151	-29.800	-0.14782E-01	6
152	-30.000	-0.14758E-01	6

INVILUPPO AZIONI INTERNE NEGLI ELEMENTI DI PARETE
 (PER UNITA' DI PROFONDITA')

* PARETE RightWall GRUPPO Right_wall*

STEP 1 - 6

* I PASSI NON EQUILIBRATI SONO ESCLUSI *

Nella tabella si stampano i seguenti risultati:

MOMENTO SX = Momento che tende le fibre sulla faccia sinistra [kN*m/m]

MOMENTO DX = Momento che tende le fibre sulla faccia destra [kN*m/m]

TAGLIO = forza tagliante (valore assoluto, priva di segno)[kN/m]

BEAM EL.	ESTREMO	QUOTA	MOMENTO SX	MOMENTO DX	TAGLIO
1	A	0.	0.7276E-10	0.1528E-09	1.242
	B	-0.2000	0.7276E-10	0.2484	1.242
2	A	-0.2000	0.2547E-09	0.2484	5.639
	B	-0.4000	0.	1.376	5.639
3	A	-0.4000	0.	1.376	9.541
	B	-0.5000	0.	2.330	9.541
4	A	-0.5000	0.	2.330	157.6
	B	-0.7000	31.18	0.	157.6
5	A	-0.7000	31.18	0.	154.5
	B	-0.9000	62.09	0.	154.5
6	A	-0.9000	62.09	0.	151.3
	B	-1.100	92.34	0.	151.3
7	A	-1.100	92.34	0.	147.7
	B	-1.300	121.9	0.	147.7
8	A	-1.300	121.9	0.	143.9
	B	-1.500	150.7	0.	143.9
9	A	-1.500	150.7	0.	139.8
	B	-1.700	178.6	0.	139.8
10	A	-1.700	178.6	0.	135.4
	B	-1.900	205.7	0.	135.4
11	A	-1.900	205.7	0.	130.8
	B	-2.100	231.8	0.	130.8
12	A	-2.100	231.8	0.	125.8
	B	-2.300	257.0	0.	125.8
13	A	-2.300	257.0	0.	120.3
	B	-2.500	281.1	0.	120.3
14	A	-2.500	281.1	0.	114.4
	B	-2.700	303.9	0.	114.4
15	A	-2.700	303.9	0.	108.0
	B	-2.900	325.5	0.	108.0
16	A	-2.900	325.5	0.	101.2
	B	-3.100	345.8	0.	101.2
17	A	-3.100	345.8	0.	93.84
	B	-3.300	364.5	0.	93.84

PARATIE 7.00

Ce.A.S. s.r.l. - Milano

PAG. 18

15 NOVEMBRE 2011 18:05:45

History 0 - ORMENIS

BEAM EL.	ESTREMO	QUOTA	MOMENTO SX	MOMENTO DX	TAGLIO
18	A	-3.300	364.5	0.	86.06
	B	-3.500	381.8	0.	86.06
19	A	-3.500	381.8	0.	77.79
	B	-3.700	397.3	0.	77.79
20	A	-3.700	397.3	0.	69.04
	B	-3.900	411.1	0.	69.04
21	A	-3.900	411.1	0.	62.11
	B	-4.000	417.3	0.	62.11
22	A	-4.000	417.3	0.	258.7
	B	-4.200	469.1	0.	258.7
23	A	-4.200	469.1	0.	248.7
	B	-4.400	518.8	0.	248.7
24	A	-4.400	518.8	0.	238.2
	B	-4.600	566.5	0.	238.2
25	A	-4.600	566.5	0.	227.2
	B	-4.800	611.9	0.	227.2
26	A	-4.800	611.9	0.	215.7
	B	-5.000	655.0	0.	215.7
27	A	-5.000	655.0	0.	205.0
	B	-5.200	696.0	0.	205.0
28	A	-5.200	696.0	0.	193.8
	B	-5.400	734.8	0.	193.8
29	A	-5.400	734.8	0.	181.9
	B	-5.600	771.2	0.	181.9
30	A	-5.600	771.2	0.	169.5
	B	-5.800	805.1	0.	169.5
31	A	-5.800	805.1	0.	156.5
	B	-6.000	836.4	0.	156.5
32	A	-6.000	836.4	0.	142.9
	B	-6.200	865.0	0.	142.9
33	A	-6.200	865.0	0.	128.6
	B	-6.400	890.7	0.	128.6
34	A	-6.400	890.7	0.	113.8
	B	-6.600	913.4	0.	113.8
35	A	-6.600	913.4	0.	98.24
	B	-6.800	933.1	0.	98.24
36	A	-6.800	933.1	0.	82.06
	B	-7.000	949.5	0.	82.06
37	A	-7.000	949.5	0.	65.22
	B	-7.200	962.5	0.	65.22
38	A	-7.200	962.5	0.	66.70
	B	-7.400	972.1	0.	66.70
39	A	-7.400	972.1	0.	88.01
	B	-7.600	978.0	0.	88.01
40	A	-7.600	978.0	0.	110.0
	B	-7.800	980.1	0.	110.0

PARATIE 7.00

Ce.A.S. s.r.l. - Milano

PAG. 19

15 NOVEMBRE 2011 18:05:45

History 0 - ORMENIS

BEAM EL.	ESTREMO	QUOTA	MOMENTO SX	MOMENTO DX	TAGLIO
41	A	-7.800	980.1	0.	132.8
	B	-8.000	978.2	0.	132.8
42	A	-8.000	978.2	0.	198.7
	B	-8.200	972.3	0.	198.7
43	A	-8.200	972.3	0.	175.5
	B	-8.400	962.1	0.	175.5
44	A	-8.400	962.1	0.	151.6
	B	-8.600	947.5	0.	151.6
45	A	-8.600	947.5	0.	127.0
	B	-8.800	931.2	0.	127.0
46	A	-8.800	931.2	0.	101.5
	B	-9.000	913.6	0.	101.5
47	A	-9.000	913.6	0.	93.96
	B	-9.200	894.8	0.	93.96
48	A	-9.200	894.8	0.	98.88
	B	-9.400	875.0	0.	98.88
49	A	-9.400	875.0	0.	103.1
	B	-9.600	854.4	0.	103.1
50	A	-9.600	854.4	0.	106.8
	B	-9.800	833.0	0.	106.8
51	A	-9.800	833.0	0.	110.0
	B	-10.00	811.0	0.	110.0
52	A	-10.00	811.0	0.	112.7
	B	-10.20	788.5	0.	112.7
53	A	-10.20	788.5	0.	115.1
	B	-10.40	765.4	0.	115.1
54	A	-10.40	765.4	0.	117.2
	B	-10.60	751.1	0.	117.2
55	A	-10.60	751.1	0.	119.0
	B	-10.80	743.0	0.	119.0
56	A	-10.80	743.0	0.	120.6
	B	-11.00	733.5	0.	120.6
57	A	-11.00	733.5	0.	121.9
	B	-11.20	722.6	0.	121.9
58	A	-11.20	722.6	0.	123.1
	B	-11.40	710.3	0.	123.1
59	A	-11.40	710.3	0.	124.1
	B	-11.60	696.8	0.	124.1
60	A	-11.60	696.8	0.	125.1
	B	-11.80	682.0	0.	125.1
61	A	-11.80	682.0	0.	125.9
	B	-12.00	666.1	0.	125.9
62	A	-12.00	666.1	0.	126.7
	B	-12.20	649.2	0.	126.7
63	A	-12.20	649.2	0.	127.4
	B	-12.40	631.1	0.	127.4

PARATIE 7.00

Ce.A.S. s.r.l. - Milano

PAG. 20

15 NOVEMBRE 2011 18:05:45

History 0 - ORMENIS

BEAM EL.	ESTREMO	QUOTA	MOMENTO SX	MOMENTO DX	TAGLIO
64	A	-12.40	631.1	0.	128.1
	B	-12.60	612.0	0.	128.1
65	A	-12.60	612.0	0.	128.8
	B	-12.80	592.0	0.	128.8
66	A	-12.80	592.0	0.	129.5
	B	-13.00	570.9	0.	129.5
67	A	-13.00	570.9	0.	130.3
	B	-13.20	549.0	0.	130.3
68	A	-13.20	549.0	0.	131.1
	B	-13.40	526.1	0.	131.1
69	A	-13.40	526.1	0.	132.0
	B	-13.60	502.2	0.	132.0
70	A	-13.60	502.2	0.	133.0
	B	-13.80	477.5	0.	133.0
71	A	-13.80	477.5	0.	134.0
	B	-14.00	451.8	0.	134.0
72	A	-14.00	451.8	0.	135.2
	B	-14.20	425.2	0.	135.2
73	A	-14.20	425.2	0.	137.4
	B	-14.40	397.7	0.	137.4
74	A	-14.40	397.7	0.	142.0
	B	-14.60	369.3	0.	142.0
75	A	-14.60	369.3	0.	146.6
	B	-14.80	340.0	0.	146.6
76	A	-14.80	340.0	0.	151.3
	B	-15.00	309.8	5.456	151.3
77	A	-15.00	309.8	5.456	143.4
	B	-15.20	281.1	12.63	143.4
78	A	-15.20	281.1	12.63	135.7
	B	-15.40	253.9	19.11	135.7
79	A	-15.40	253.9	19.11	128.1
	B	-15.60	228.3	24.94	128.1
80	A	-15.60	228.3	24.94	120.7
	B	-15.80	204.2	30.14	120.7
81	A	-15.80	204.2	30.14	113.5
	B	-16.00	181.5	34.74	113.5
82	A	-16.00	181.5	34.74	106.4
	B	-16.20	160.2	38.78	106.4
83	A	-16.20	160.2	38.78	99.50
	B	-16.40	140.3	42.28	99.50
84	A	-16.40	140.3	42.28	92.81
	B	-16.60	121.7	45.26	92.81
85	A	-16.60	121.7	45.26	86.32
	B	-16.80	104.5	47.77	86.32
86	A	-16.80	104.5	47.77	80.03
	B	-17.00	88.46	49.82	80.03

PARATIE 7.00

Ce.A.S. s.r.l. - Milano

PAG. 21

15 NOVEMBRE 2011 18:05:45

History 0 - ORMENIS

BEAM EL.	ESTREMO	QUOTA	MOMENTO SX	MOMENTO DX	TAGLIO
87	A	-17.00	88.46	49.82	73.94
	B	-17.20	73.67	51.45	73.94
88	A	-17.20	73.67	51.45	68.06
	B	-17.40	60.06	52.67	68.06
89	A	-17.40	60.06	52.67	62.39
	B	-17.60	47.58	53.51	62.39
90	A	-17.60	47.58	53.51	56.94
	B	-17.80	36.19	55.55	56.94
91	A	-17.80	36.19	55.55	51.69
	B	-18.00	26.38	62.01	51.69
92	A	-18.00	26.38	62.01	46.66
	B	-18.20	18.89	67.45	46.66
93	A	-18.20	18.89	67.45	41.85
	B	-18.40	12.15	71.94	41.85
94	A	-18.40	12.15	71.94	37.25
	B	-18.60	6.132	75.52	37.25
95	A	-18.60	6.132	75.52	32.87
	B	-18.80	0.7901	78.24	32.87
96	A	-18.80	0.7901	78.24	28.70
	B	-19.00	0.	80.16	28.70
97	A	-19.00	0.	80.16	24.75
	B	-19.20	0.	81.33	24.75
98	A	-19.20	0.	81.33	21.01
	B	-19.40	0.	81.80	21.01
99	A	-19.40	0.	81.80	17.48
	B	-19.60	0.	81.63	17.48
100	A	-19.60	0.	81.63	14.16
	B	-19.80	0.	80.85	14.16
101	A	-19.80	0.	80.85	11.05
	B	-20.00	0.	79.52	11.05
102	A	-20.00	0.	79.52	10.03
	B	-20.20	0.	77.69	10.03
103	A	-20.20	0.	77.69	11.43
	B	-20.40	0.	75.40	11.43
104	A	-20.40	0.	75.40	13.47
	B	-20.60	0.	72.71	13.47
105	A	-20.60	0.	72.71	15.27
	B	-20.80	0.	69.66	15.27
106	A	-20.80	0.	69.66	16.85
	B	-21.00	0.	66.29	16.85
107	A	-21.00	0.	66.29	18.20
	B	-21.20	0.	62.65	18.20
108	A	-21.20	0.	62.65	19.32
	B	-21.40	0.	58.78	19.32
109	A	-21.40	0.	58.78	20.22
	B	-21.60	0.	54.74	20.22

PARATIE 7.00

Ce.A.S. s.r.l. - Milano

PAG. 22

15 NOVEMBRE 2011 18:05:45

History 0 - ORMENIS

BEAM EL.	ESTREMO	QUOTA	MOMENTO SX	MOMENTO DX	TAGLIO
110	A	-21.60	0.	54.74	20.90
	B	-21.80	0.	50.56	20.90
111	A	-21.80	0.	50.56	21.37
	B	-22.00	0.	46.28	21.37
112	A	-22.00	0.	46.28	21.61
	B	-22.20	0.	41.96	21.61
113	A	-22.20	0.	41.96	21.64
	B	-22.40	0.	37.63	21.64
114	A	-22.40	0.	37.63	21.46
	B	-22.60	0.	33.34	21.46
115	A	-22.60	0.	33.34	21.06
	B	-22.80	0.	29.13	21.06
116	A	-22.80	0.	29.13	20.46
	B	-23.00	0.	25.04	20.46
117	A	-23.00	0.	25.04	19.64
	B	-23.20	0.	21.11	19.64
118	A	-23.20	0.	21.11	18.61
	B	-23.40	0.	17.39	18.61
119	A	-23.40	0.	17.39	17.38
	B	-23.60	0.	13.91	17.38
120	A	-23.60	0.	13.91	15.93
	B	-23.80	0.	10.72	15.93
121	A	-23.80	0.	10.72	14.28
	B	-24.00	0.	7.868	14.28
122	A	-24.00	0.	7.868	12.42
	B	-24.20	0.	5.384	12.42
123	A	-24.20	0.	5.384	10.35
	B	-24.40	0.	3.314	10.35
124	A	-24.40	0.	3.314	8.076
	B	-24.60	0.	1.698	8.076
125	A	-24.60	0.	1.698	5.592
	B	-24.80	0.	0.5800	5.592
126	A	-24.80	0.	0.5800	2.900
	B	-25.00	0.9532E-09	0.7058E-09	2.900

PARATIE 7.00
15 NOVEMBRE 2011 18:05:45
History 0 - ORMENIS

Ce.A.S. s.r.l. - Milano

PAG. 23

FORZE NEGLI ANCORAGGI ATTIVI (PER UNITA' DI PROFONDITA')

TIRANTE	Wire01	1 PARETE RightWall	QUOTA	-0.50000
		FASE 1 FORZA	150.00	kN/m
		FASE 2 FORZA	167.85	kN/m
		FASE 3 FORZA	156.57	kN/m
		FASE 4 FORZA	174.72	kN/m
		FASE 5 FORZA	163.50	kN/m
		FASE 6 FORZA	184.85	kN/m
TIRANTE	Wire2	1 PARETE RightWall	QUOTA	-4.0000
		FASE 1 inattivo		
		FASE 2 inattivo		
		FASE 3 FORZA	150.00	kN/m
		FASE 4 FORZA	220.51	kN/m
		FASE 5 FORZA	192.23	kN/m
		FASE 6 FORZA	231.09	kN/m
TIRANTE	Wire3	1 PARETE RightWall	QUOTA	-8.0000
		FASE 1 inattivo		
		FASE 2 inattivo		
		FASE 3 inattivo		
		FASE 4 inattivo		
		FASE 5 FORZA	300.00	kN/m
		FASE 6 FORZA	346.50	kN/m

INVILUPPO RISULTATI NEGLI ELEMENTI TERRENO

* PARETE RightWall GRUPPO DRight*

STEP 1 - 6

* I PASSI NON EQUILIBRATI SONO ESCLUSI *

Nella tabella si stampano i seguenti risultati:

SIGMA-H = massimo sforzo orizzontale efficace [kPa]

TAGLIO = massimo sforzo di taglio [kPa]

PR. ACQUA =massima pressione interstiziale [kPa]

GRAD. MAX =massimo gradiente idraulico

SOIL EL.	QUOTA	SIGMA-H	TAGLIO	PR. ACQUA	GRAD. MAX
1	0.	0.	0.	0.	0.
2	-0.2000	0.	0.	0.	0.
3	-0.4000	0.	0.	0.	0.
4	-0.5000	0.	0.	0.	0.
5	-0.7000	1.364	1.218	0.	0.
6	-0.9000	2.728	2.436	0.	0.
7	-1.100	4.093	3.654	0.	0.
8	-1.300	5.457	4.872	0.	0.
9	-1.500	6.821	6.089	0.	0.
10	-1.700	8.185	7.307	0.	0.
11	-1.900	10.52	8.040	0.	0.
12	-2.100	15.33	7.535	0.	0.
13	-2.300	20.12	7.039	0.	0.
14	-2.500	24.89	6.553	0.	0.
15	-2.700	29.64	6.078	0.	0.
16	-2.900	34.37	5.614	0.	0.
17	-3.100	39.07	5.163	0.	0.
18	-3.300	43.75	4.723	0.	0.
19	-3.500	48.41	4.297	0.	0.
20	-3.700	53.03	3.884	0.	0.
21	-3.900	57.63	3.484	0.	0.
22	-4.000	59.92	3.289	0.	0.
23	-4.200	64.48	2.910	2.074	0.3704E-01
24	-4.400	69.01	4.002	4.148	0.3704E-01
25	-4.600	73.51	6.004	6.222	0.3704E-01
26	-4.800	77.99	8.005	8.296	0.3704E-01
27	-5.000	82.36	19.34	10.37	0.3704E-01
28	-5.200	87.19	20.60	12.44	0.3704E-01
29	-5.400	92.00	21.74	14.52	0.3704E-01
30	-5.600	96.78	22.81	16.59	0.3704E-01
31	-5.800	101.5	23.80	18.67	0.3704E-01
32	-6.000	106.2	24.71	20.74	0.3704E-01
33	-6.200	110.8	25.56	22.81	0.3704E-01
34	-6.400	115.4	26.37	24.89	0.3704E-01
35	-6.600	120.0	27.15	26.96	0.3704E-01

PARATIE 7.00

Ce.A.S. s.r.l. - Milano

PAG. 25

15 NOVEMBRE 2011 18:05:45

History 0 - ORMENIS

SOIL EL.	QUOTA	SIGMA-H	TAGLIO	PR. ACQUA	GRAD. MAX
36	-6.800	124.5	27.89	29.04	0.3704E-01
37	-7.000	129.0	28.60	31.11	0.3704E-01
38	-7.200	133.5	29.29	33.19	0.3704E-01
39	-7.400	138.0	29.96	35.26	0.3704E-01
40	-7.600	142.5	30.60	37.33	0.3704E-01
41	-7.800	146.9	31.22	39.41	0.3704E-01
42	-8.000	151.4	31.82	41.48	0.3704E-01
43	-8.200	155.8	32.40	43.56	0.3704E-01
44	-8.400	160.2	32.97	45.63	0.3704E-01
45	-8.600	164.5	34.98	47.70	0.1313
46	-8.800	168.9	39.00	49.78	0.1313
47	-9.000	173.3	41.66	51.85	0.1313
48	-9.200	177.6	43.75	53.93	0.1313
49	-9.400	181.9	45.52	56.00	0.1313
50	-9.600	186.2	47.06	58.07	0.1546
51	-9.800	190.5	48.44	60.15	0.1546
52	-10.00	194.8	49.69	62.22	0.1546
53	-10.20	199.1	50.83	64.30	0.1546
54	-10.40	203.3	51.89	66.37	0.1546
55	-10.60	207.6	52.86	68.44	0.1546
56	-10.80	211.8	53.78	70.52	0.1546
57	-11.00	216.1	54.63	72.59	0.1546
58	-11.20	220.3	55.44	74.67	0.1546
59	-11.40	224.5	56.19	76.74	0.1546
60	-11.60	228.7	57.19	78.81	0.1546
61	-11.80	232.9	58.17	80.89	0.1546
62	-12.00	237.1	59.09	82.96	0.1546
63	-12.20	241.3	59.96	85.04	0.1546
64	-12.40	245.5	60.78	87.11	0.1546
65	-12.60	249.6	61.56	89.19	0.1546
66	-12.80	253.8	62.30	91.26	0.1546
67	-13.00	258.0	63.00	93.33	0.1546
68	-13.20	262.2	63.67	95.41	0.1546
69	-13.40	266.3	64.31	97.48	0.1546
70	-13.60	270.5	64.92	99.56	0.1546
71	-13.80	274.6	65.50	101.6	0.1546
72	-14.00	278.8	66.06	103.7	0.1546
73	-14.20	282.9	66.59	105.8	0.1546
74	-14.40	287.1	67.10	107.9	0.1546
75	-14.60	291.2	67.60	109.9	0.1546
76	-14.80	295.4	68.07	112.0	0.1546
77	-15.00	301.5	81.75	114.1	0.1546
78	-15.20	305.6	82.13	116.1	0.1546
79	-15.40	309.7	82.48	118.2	0.1546
80	-15.60	313.8	82.83	120.3	0.1546
81	-15.80	317.9	83.16	122.4	0.1546

PARATIE 7.00

Ce.A.S. s.r.l. - Milano

PAG. 26

15 NOVEMBRE 2011 18:05:45

History 0 - ORMENIS

SOIL EL.	QUOTA	SIGMA-H	TAGLIO	PR. ACQUA	GRAD. MAX
82	-16.00	322.1	83.47	124.4	0.1546
83	-16.20	326.2	83.78	126.5	0.1546
84	-16.40	330.3	84.08	128.6	0.1546
85	-16.60	334.4	84.37	130.7	0.1546
86	-16.80	338.5	84.65	132.7	0.1546
87	-17.00	342.6	84.93	134.8	0.1546
88	-17.20	346.7	85.20	136.9	0.1546
89	-17.40	350.9	85.47	139.0	0.1546
90	-17.60	355.0	85.73	141.0	0.1546
91	-17.80	359.1	85.99	143.1	0.1546
92	-18.00	363.2	86.24	145.2	0.1546
93	-18.20	367.3	86.50	147.3	0.1546
94	-18.40	371.5	86.75	149.3	0.1546
95	-18.60	375.6	87.00	151.4	0.1546
96	-18.80	379.7	87.25	153.5	0.1546
97	-19.00	383.9	87.49	155.6	0.1546
98	-19.20	388.0	87.74	157.6	0.1546
99	-19.40	392.1	87.99	159.7	0.1546
100	-19.60	396.3	88.23	161.8	0.1546
101	-19.80	400.4	88.48	163.9	0.1546
102	-20.00	404.6	88.73	165.9	0.1546
103	-20.20	408.7	88.98	168.0	0.1546
104	-20.40	412.8	89.22	170.1	0.1546
105	-20.60	417.0	89.47	172.1	0.1546
106	-20.80	421.1	89.72	174.2	0.1546
107	-21.00	425.3	89.97	176.3	0.1546
108	-21.20	429.4	90.22	178.4	0.1546
109	-21.40	433.6	90.47	180.4	0.1546
110	-21.60	437.7	90.72	182.5	0.1546
111	-21.80	441.9	90.97	184.6	0.1546
112	-22.00	446.1	91.22	186.7	0.1546
113	-22.20	450.2	91.47	188.7	0.1546
114	-22.40	454.4	91.72	190.8	0.1546
115	-22.60	458.5	91.97	192.9	0.1546
116	-22.80	462.7	92.22	195.0	0.1546
117	-23.00	466.8	92.47	197.0	0.1546
118	-23.20	471.0	92.72	199.1	0.1546
119	-23.40	475.2	92.97	201.2	0.1546
120	-23.60	479.3	93.22	203.3	0.1546
121	-23.80	483.5	93.47	205.3	0.1546
122	-24.00	487.6	93.72	207.4	0.1546
123	-24.20	491.8	93.97	209.5	0.1546
124	-24.40	496.0	94.22	211.6	0.1546
125	-24.60	500.1	94.47	213.6	0.1546
126	-24.80	504.3	94.71	215.7	0.1546
127	-25.00	508.5	94.96	217.8	0.1546

PARATIE 7.00

Ce.A.S. s.r.l. - Milano

PAG. 27

15 NOVEMBRE 2011 18:05:45

History 0 - ORMENIS

SOIL EL.	QUOTA	SIGMA-H	TAGLIO	PR. ACQUA	GRAD. MAX
128	-25.20	513.3	97.45	219.9	0.1546
129	-25.40	517.5	97.90	221.9	0.1546
130	-25.60	521.7	98.34	224.0	0.1546
131	-25.80	525.9	98.79	226.1	0.1546
132	-26.00	530.1	99.23	228.1	0.1546
133	-26.20	534.3	99.67	230.2	0.1546
134	-26.40	538.5	100.1	232.3	0.1546
135	-26.60	542.7	100.6	234.4	0.1546
136	-26.80	546.9	101.0	236.4	0.1546
137	-27.00	551.1	101.4	238.5	0.1546
138	-27.20	555.3	101.9	240.6	0.1546
139	-27.40	559.5	102.3	242.7	0.1546
140	-27.60	563.7	102.8	244.7	0.1546
141	-27.80	567.9	103.2	246.8	0.1546
142	-28.00	572.1	103.6	248.9	0.1546
143	-28.20	576.3	104.1	251.0	0.1546
144	-28.40	580.5	104.5	253.0	0.1546
145	-28.60	584.7	105.0	255.1	0.1546
146	-28.80	588.9	105.4	257.2	0.1546
147	-29.00	593.1	105.8	259.3	0.1546
148	-29.20	597.3	106.3	261.3	0.1546
149	-29.40	601.5	106.7	263.4	0.1546
150	-29.60	605.7	107.1	265.5	0.1546
151	-29.80	609.9	107.6	267.6	0.1546
152	-30.00	614.1	108.0	269.6	0.1546

INVILUPPO RISULTATI NEGLI ELEMENTI TERRENO

* PARETE RightWall GRUPPO UHRight*

STEP 1 - 6

* I PASSI NON EQUILIBRATI SONO ESCLUSI *

Nella tabella si stampano i seguenti risultati:

SIGMA-H = massimo sforzo orizzontale efficace [kPa]

TAGLIO = massimo sforzo di taglio [kPa]

PR. ACQUA =massima pressione interstiziale [kPa]

GRAD. MAX =massimo gradiente idraulico

SOIL EL.	QUOTA	SIGMA-H	TAGLIO	PR. ACQUA	GRAD. MAX
1	0.	12.42	5.291	0.	0.
2	-0.2000	21.99	4.406	0.	0.
3	-0.4000	26.01	8.812	0.	0.
4	-0.5000	31.66	11.02	0.	0.
5	-0.7000	34.92	10.81	0.	0.
6	-0.9000	37.68	10.29	0.	0.
7	-1.100	40.45	9.773	0.	0.
8	-1.300	43.22	9.259	0.	0.
9	-1.500	46.00	8.750	0.	0.
10	-1.700	48.79	8.247	0.	0.
11	-1.900	51.60	8.265	0.	0.
12	-2.100	54.43	9.403	0.9630	0.1546
13	-2.300	57.27	10.53	2.889	0.1546
14	-2.500	60.14	11.65	4.815	0.1546
15	-2.700	63.02	12.75	6.741	0.1546
16	-2.900	65.93	13.84	8.667	0.1546
17	-3.100	68.85	14.91	10.59	0.1546
18	-3.300	71.81	15.98	12.52	0.1546
19	-3.500	74.79	17.02	14.44	0.1546
20	-3.700	77.79	18.05	16.37	0.1546
21	-3.900	80.82	19.07	18.30	0.1546
22	-4.000	82.34	19.57	19.26	0.1546
23	-4.200	85.41	20.56	21.19	0.1546
24	-4.400	88.51	21.54	23.11	0.1546
25	-4.600	91.63	22.50	25.04	0.1546
26	-4.800	94.78	23.27	26.96	0.1546
27	-5.000	98.48	27.44	28.89	0.1546
28	-5.200	102.0	28.06	30.81	0.1546
29	-5.400	105.5	28.66	32.74	0.1546
30	-5.600	109.1	29.24	34.67	0.1546
31	-5.800	112.7	29.79	36.59	0.1546
32	-6.000	116.3	30.31	38.52	0.1546
33	-6.200	119.9	30.84	40.44	0.1546
34	-6.400	123.4	31.37	42.37	0.1546
35	-6.600	127.0	31.87	44.30	0.1546

PARATIE 7.00

Ce.A.S. s.r.l. - Milano

PAG. 29

15 NOVEMBRE 2011 18:05:45

History 0 - ORMENIS

SOIL EL.	QUOTA	SIGMA-H	TAGLIO	PR. ACQUA	GRAD. MAX
36	-6.800	130.6	32.34	46.22	0.1546
37	-7.000	134.3	32.77	48.15	0.1546
38	-7.200	137.9	33.17	50.07	0.1546
39	-7.400	141.7	33.54	52.00	0.1546
40	-7.600	145.4	33.88	53.93	0.1546
41	-7.800	149.2	34.19	55.85	0.1546
42	-8.000	153.0	34.46	57.78	0.1546
43	-8.200	156.9	34.71	59.70	0.1546
44	-8.400	160.7	34.93	61.63	0.1546
45	-8.600	164.6	35.11	63.56	0.1546
46	-8.800	168.5	35.26	65.48	0.1546
47	-9.000	172.5	35.38	67.41	0.1546
48	-9.200	176.5	35.47	69.33	0.1546
49	-9.400	180.5	35.52	71.26	0.1546
50	-9.600	184.5	35.55	73.19	0.1546
51	-9.800	188.5	35.54	75.11	0.1546
52	-10.00	192.6	35.49	77.04	0.1546
53	-10.20	196.6	35.42	78.96	0.1546
54	-10.40	200.7	35.31	80.89	0.1546
55	-10.60	204.8	35.18	82.81	0.1546
56	-10.80	209.0	35.01	84.74	0.1546
57	-11.00	213.1	34.81	86.67	0.1546
58	-11.20	217.3	34.59	88.59	0.1546
59	-11.40	221.4	34.34	90.52	0.1546
60	-11.60	225.6	34.06	92.44	0.1546
61	-11.80	229.8	33.75	94.37	0.1546
62	-12.00	234.0	33.41	96.30	0.1546
63	-12.20	238.3	33.05	98.22	0.1546
64	-12.40	242.5	32.67	100.1	0.1546
65	-12.60	246.7	32.26	102.1	0.1546
66	-12.80	251.0	31.83	104.0	0.1546
67	-13.00	255.2	31.38	105.9	0.1546
68	-13.20	259.5	30.90	107.9	0.1546
69	-13.40	263.8	30.41	109.8	0.1546
70	-13.60	268.0	29.90	111.7	0.1546
71	-13.80	272.3	29.37	113.6	0.1546
72	-14.00	276.6	28.82	115.6	0.1546
73	-14.20	280.9	28.26	117.5	0.1546
74	-14.40	285.2	27.68	119.4	0.1546
75	-14.60	289.5	27.09	121.3	0.1546
76	-14.80	293.8	26.48	123.3	0.1546
77	-15.00	295.3	44.18	125.2	0.1546
78	-15.20	299.6	43.46	127.1	0.1546
79	-15.40	304.0	42.72	129.0	0.1546
80	-15.60	308.3	41.97	131.0	0.1546
81	-15.80	312.7	41.21	132.9	0.1546

PARATIE 7.00

Ce.A.S. s.r.l. - Milano

PAG. 30

15 NOVEMBRE 2011 18:05:45

History 0 - ORMENIS

SOIL EL.	QUOTA	SIGMA-H	TAGLIO	PR. ACQUA	GRAD. MAX
82	-16.00	317.0	40.45	134.8	0.1546
83	-16.20	321.4	39.68	136.7	0.1546
84	-16.40	325.7	38.90	138.7	0.1546
85	-16.60	330.1	38.11	140.6	0.1546
86	-16.80	334.4	37.33	142.5	0.1546
87	-17.00	338.7	36.54	144.4	0.1546
88	-17.20	343.1	35.75	146.4	0.1546
89	-17.40	347.4	34.96	148.3	0.1546
90	-17.60	351.7	34.16	150.2	0.1546
91	-17.80	356.1	33.37	152.1	0.1546
92	-18.00	360.4	32.58	154.1	0.1546
93	-18.20	364.7	31.79	156.0	0.1546
94	-18.40	369.0	31.00	157.9	0.1546
95	-18.60	373.3	30.21	159.9	0.1546
96	-18.80	377.6	29.43	161.8	0.1546
97	-19.00	382.0	28.64	163.7	0.1546
98	-19.20	386.3	27.86	165.6	0.1546
99	-19.40	390.6	27.09	167.6	0.1546
100	-19.60	394.9	26.31	169.5	0.1546
101	-19.80	399.2	25.54	171.4	0.1546
102	-20.00	403.4	24.77	173.3	0.1546
103	-20.20	407.7	24.01	175.3	0.1546
104	-20.40	412.0	23.25	177.2	0.1546
105	-20.60	416.3	22.49	179.1	0.1546
106	-20.80	420.6	21.73	181.0	0.1546
107	-21.00	424.9	21.93	183.0	0.1546
108	-21.20	429.2	22.47	184.9	0.1546
109	-21.40	433.4	23.00	186.8	0.1546
110	-21.60	437.7	23.52	188.7	0.1546
111	-21.80	442.0	24.05	190.7	0.1546
112	-22.00	446.2	24.57	192.6	0.1546
113	-22.20	450.5	25.09	194.5	0.1546
114	-22.40	454.8	25.61	196.4	0.1546
115	-22.60	459.1	26.13	198.4	0.1546
116	-22.80	463.3	26.65	200.3	0.1546
117	-23.00	467.6	27.16	202.2	0.1546
118	-23.20	471.9	27.68	204.1	0.1546
119	-23.40	476.1	28.19	206.1	0.1546
120	-23.60	480.4	28.70	208.0	0.1546
121	-23.80	484.6	29.21	209.9	0.1546
122	-24.00	488.9	29.73	211.9	0.1546
123	-24.20	493.2	30.24	213.8	0.1546
124	-24.40	497.4	30.75	215.7	0.1546
125	-24.60	501.7	31.26	217.6	0.1546
126	-24.80	506.0	31.77	219.6	0.1546
127	-25.00	510.2	32.28	221.5	0.1546

PARATIE 7.00

Ce.A.S. s.r.l. - Milano

PAG. 31

15 NOVEMBRE 2011 18:05:45

History 0 - ORMENIS

SOIL EL.	QUOTA	SIGMA-H	TAGLIO	PR. ACQUA	GRAD. MAX
128	-25.20	513.3	31.02	223.4	0.1546
129	-25.40	517.5	31.44	225.3	0.1546
130	-25.60	521.7	31.87	227.3	0.1546
131	-25.80	525.9	32.29	229.2	0.1546
132	-26.00	530.1	32.72	231.1	0.1546
133	-26.20	534.3	33.14	233.0	0.1546
134	-26.40	538.5	33.56	235.0	0.1546
135	-26.60	542.7	33.99	236.9	0.1546
136	-26.80	546.9	34.41	238.8	0.1546
137	-27.00	551.1	34.83	240.7	0.1546
138	-27.20	555.3	35.26	242.7	0.1546
139	-27.40	559.5	35.68	244.6	0.1546
140	-27.60	563.7	36.10	246.5	0.1546
141	-27.80	567.9	36.53	248.4	0.1546
142	-28.00	572.1	36.95	250.4	0.1546
143	-28.20	576.3	37.37	252.3	0.1546
144	-28.40	580.5	37.80	254.2	0.1546
145	-28.60	584.7	38.22	256.1	0.1546
146	-28.80	588.9	38.65	258.1	0.1546
147	-29.00	593.1	39.07	260.0	0.1546
148	-29.20	597.3	39.49	261.9	0.1546
149	-29.40	601.5	39.91	263.9	0.1546
150	-29.60	605.7	40.34	265.8	0.1546
151	-29.80	609.9	40.76	267.7	0.1546
152	-30.00	614.1	41.18	269.6	0.1546

RIASSUNTO SPINTE NEGLI ELEMENTI TERRENO
(LE SPINTE SONO CALCOLATE INTEGRANDO GLI SFORZI NEI SINGOLI ELEMENTI MOLLA)

SPINTA EFFICACE VERA = Integrale delle pressioni orizzontali efficaci in tutti gli elementi nel gruppo: unita' di misura kN/m

SPINTA ACQUA = Integrale delle pressioni interstiziali in tutti gli elementi nel gruppo: unita' di misura kN/m

SPINTA TOTALE VERA = Somma della SPINTA EFFICACE e della SPINTA DELL'ACQUA: e' l' azione totale sulla parete: unita' di misura kN/m

SPINTA ATTIVA POSSIBILE = La minima spinta che puo' essere esercitata da questo gruppo di elementi terreno, in questa fase: unita' di misura kN/m

SPINTA PASSIVA POSSIBILE = La massima spinta che puo' essere esercitata da questo gruppo di elementi terreno, in questa fase: unita' di misura kN/m

RAPPORTO PASSIVA/VERA = e' il rapporto tra la massima spinta possibile e la spinta efficace vera: fornisce un'indicazione su quanta spinta passiva venga mobilitata;

SPINTA PASSIVA MOBILITATA = e' l'inverso del rapporto precedente, espresso in unita' percentuale: indica quanta parte della massima spinta possibile e' stata mobilitata;

RAPPORTO VERA/ATTIVA = e' il rapporto tra la spinta efficace vera e la minima spinta possibile: fornisce un'indicazione di quanto questa porzione di terreno sia prossima alla condizione di massimo rilascio.

FASE	1	GRUPPO -->	DHRi	UHRi
SPINTA EFFICACE VERA			8943.6	9082.2
SPINTA ACQUA			0.	0.
SPINTA TOTALE VERA			8943.6	9082.2
SPINTA ATTIVA (POSSIBILE)			1921.3	2012.7
SPINTA PASSIVA (POSSIBILE)			38013.	39097.
RAPPORTO PASSIVA/VERA			4.2504	4.3048
SPINTA PASSIVA MOBILITATA			24.%	23.%
RAPPORTO VERA/ATTIVA			4.6551	4.5124

PARATIE 7.00

Ce.A.S. s.r.l. - Milano

PAG. 33

15 NOVEMBRE 2011 18:05:45

History 0 - ORMENIS

FASE	2	GRUPPO -->	DHRi	UHRi
		SPINTA EFFICACE VERA	6182.7	6068.0
		SPINTA ACQUA	3505.2	3774.9
		SPINTA TOTALE VERA	9687.8	9842.9
		SPINTA ATTIVA (POSSIBILE)	289.51	814.88
		SPINTA PASSIVA (POSSIBILE)	17101.	24290.
		RAPPORTO PASSIVA/VERA	2.7660	4.0030
		SPINTA PASSIVA MOBILITATA	36.%	25.%
		RAPPORTO VERA/ATTIVA	21.356	7.4466

FASE	3	GRUPPO -->	DHRi	UHRi
		SPINTA EFFICACE VERA	6149.7	6163.3
		SPINTA ACQUA	3505.2	3774.9
		SPINTA TOTALE VERA	9654.9	9938.2
		SPINTA ATTIVA (POSSIBILE)	289.51	814.88
		SPINTA PASSIVA (POSSIBILE)	17101.	24290.
		RAPPORTO PASSIVA/VERA	2.7808	3.9411
		SPINTA PASSIVA MOBILITATA	36.%	25.%
		RAPPORTO VERA/ATTIVA	21.242	7.5635

FASE	4	GRUPPO -->	DHRi	UHRi
		SPINTA EFFICACE VERA	5538.0	5112.6
		SPINTA ACQUA	2614.8	3405.3
		SPINTA TOTALE VERA	8152.8	8517.9
		SPINTA ATTIVA (POSSIBILE)	71.669	931.82
		SPINTA PASSIVA (POSSIBILE)	11699.	25740.
		RAPPORTO PASSIVA/VERA	2.1124	5.0345
		SPINTA PASSIVA MOBILITATA	47.%	20.%
		RAPPORTO VERA/ATTIVA	77.272	5.4867

FASE	5	GRUPPO -->	DHRi	UHRi
		SPINTA EFFICACE VERA	5477.4	5292.7
		SPINTA ACQUA	2614.8	3405.3
		SPINTA TOTALE VERA	8092.2	8698.0
		SPINTA ATTIVA (POSSIBILE)	71.669	931.82
		SPINTA PASSIVA (POSSIBILE)	11699.	25740.
		RAPPORTO PASSIVA/VERA	2.1358	4.8632
		SPINTA PASSIVA MOBILITATA	47.%	21.%
		RAPPORTO VERA/ATTIVA	76.426	5.6800

PARATIE 7.00

Ce.A.S. s.r.l. - Milano

PAG. 34

15 NOVEMBRE 2011 18:05:45

History 0 - ORMENIS

FASE	6	GRUPPO -->	DHRi	UHRi
		SPINTA EFFICACE VERA	5427.9	5244.7
		SPINTA ACQUA	2426.2	3313.9
		SPINTA TOTALE VERA	7854.1	8558.5
		SPINTA ATTIVA (POSSIBILE)	44.845	1184.2
		SPINTA PASSIVA (POSSIBILE)	10628.	28741.
		RAPPORTO PASSIVA/VERA	1.9579	5.4800
		SPINTA PASSIVA MOBILITATA	51.%	18.%
		RAPPORTO VERA/ATTIVA	121.04	4.4290

OUTPUT PLOTS:

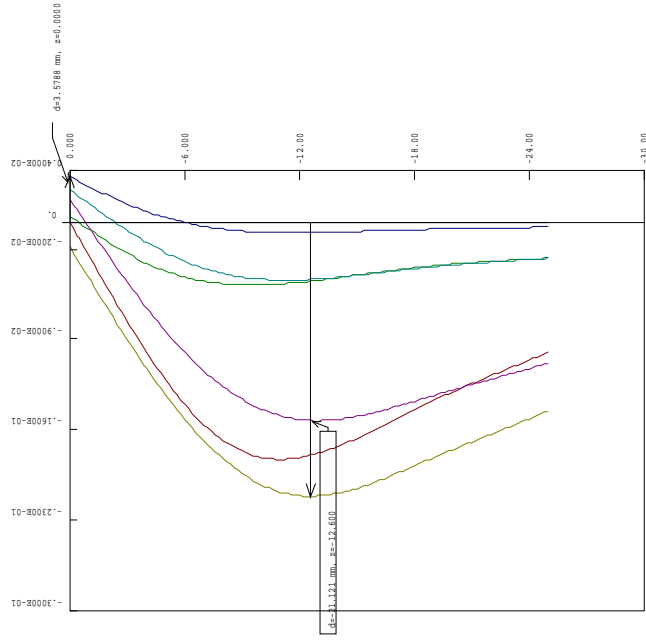

- step 6
- step 5
- step 4
- step 3
- step 2
- step 1

FATTORE SCALA: 2.46 - FATTORE AMPLIF.: 636.71
 DEFORMATA PASSI 1 / 6 [m]

Pecece units= N
 Length units= M

* Ce.A.S. S.r.l. Milano *
 www.ceas.it
 P A R A T I E 7.00
 15 NOVEMBRE 2011 18:05:45

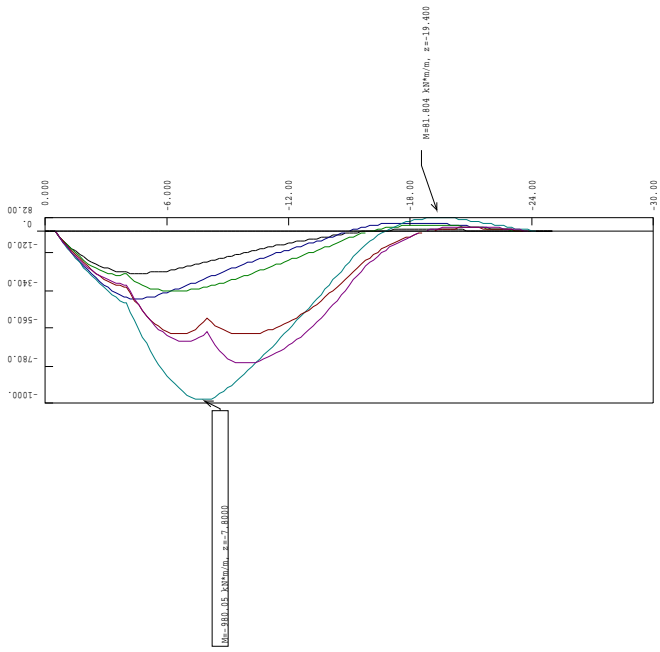

Step 6
 Step 5
 Step 4
 Step 3
 Step 2
 Step 1

MOMENTI FLETTENTI [kN*m/m]
 INVILUPPO DA 1 A 6 SCALA GEOM. : 2,32

Pezzo unita= KN
 Lunghezza unita= M

* Ce.A.S. S.r.l. Milano *
 www.ceas.it
 P A R A T I E 7.00

15 NOVEMBRE 2011 18:05:45

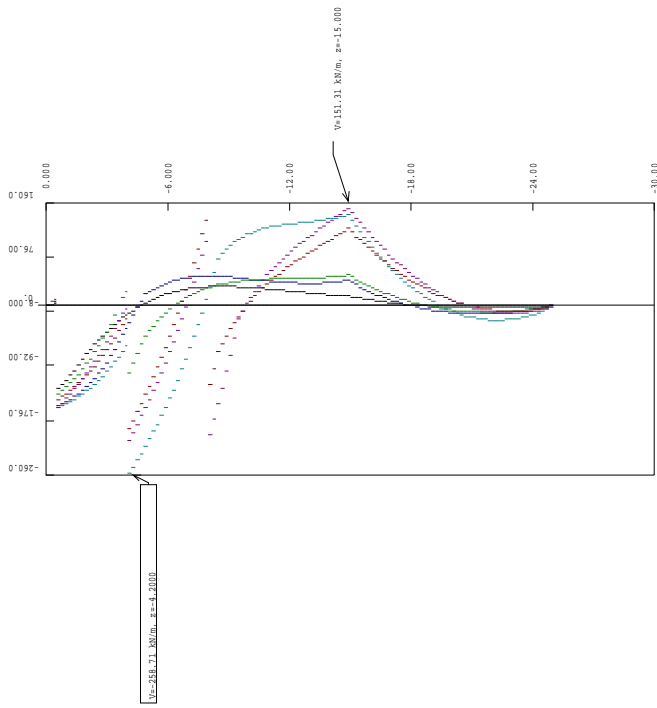

- Step 6
- Step 5
- Step 4
- Step 3
- Step 2
- Step 1

TAGLI [KN/m]
 INVILUPPO DA 1 A 6 SCALA GEOM. : 2,32

URB... C:\Users\ADMINISTRATORE\Documents\cassaella_111\Bella_Busella_Gommita_Foto_Gommita\STEP_AUSTRAL_15DM_1422011

Perce unit= KN
 Length unit= M

* Ce.A.S. S.r.l. Milano *
 www.ceas.it
 P A R A T I E 7.00
 15 NOVEMBRE 2011 18:05:45

Tirante Wire01	
STEP	FORCE [KN/m]
1.	150.
2.	167.8
3.	156.6
4.	174.7
5.	163.5
6.	184.8

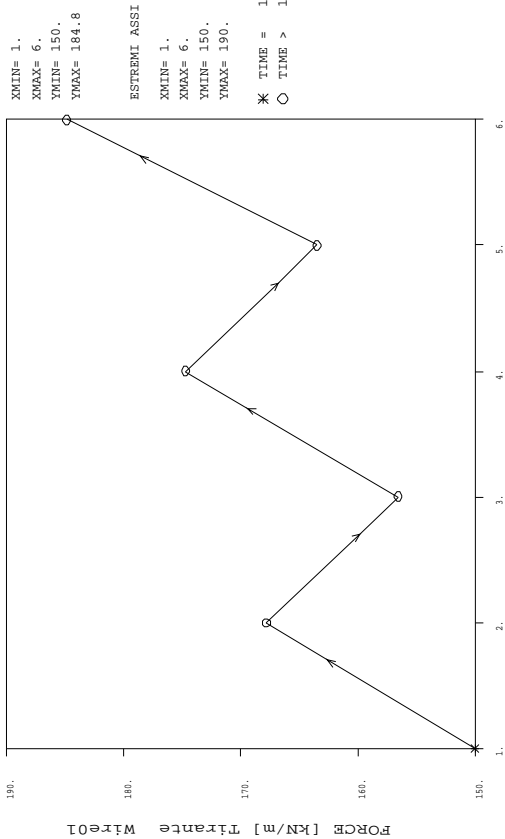

STEP

DAL PASSO 1 AL PASSO 6
 DIAGRAMMA VARIABILE X / VARIABILE Y

HERSCY 0 - OMENIS

C:\Users\ATomelec\Documents\cattella_11\Belle_Buonile\cattella_11\data\csm\csm\csm\lanc\lanc_01\lanc_01_01.d3dout

Piece unita= KN
 Length unita= M

* Ce.A.S. S.r.l. Milano *
 www.ceas.it
 P A R A T I E 7.00
 15 NOVEMBRE 2011 18:05:45

Tirante_Wire2	FORCE [KN/m]
1.	0.
2.	0.
3.	150.
4.	220.5
5.	192.2
6.	231.1

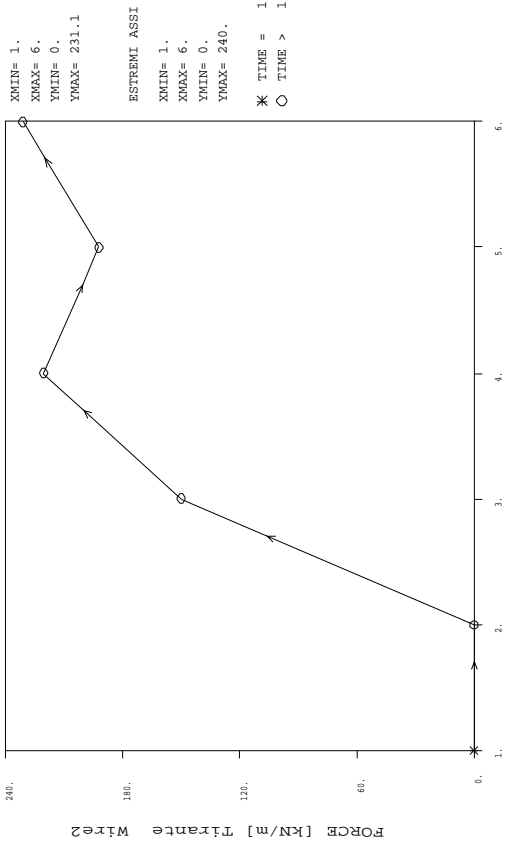

STEP

DAL PASSO 1 AL PASSO 6
 DIAGRAMMA VARIABILE X / VARIABILE Y

Hierarchy 0 - OMENIS
 C:\Users\A7em1ed\Documents\cassa11a\1111\k11a_Du0001a00010\k11a_Du0001a00010\k11a_Du0001a00010.k11a

Piece writes KN
 Length writes M

* Ce.A.S. S.r.l. Milano *
 www.ceas.it
 P A R A T I E 7.00
 15 NOVEMBRE 2011 18:05:45

Tirante_Wire3	
STEP	FORCE [KN/m]
1.	0.
2.	0.
3.	0.
4.	0.
5.	300.
6.	346.5

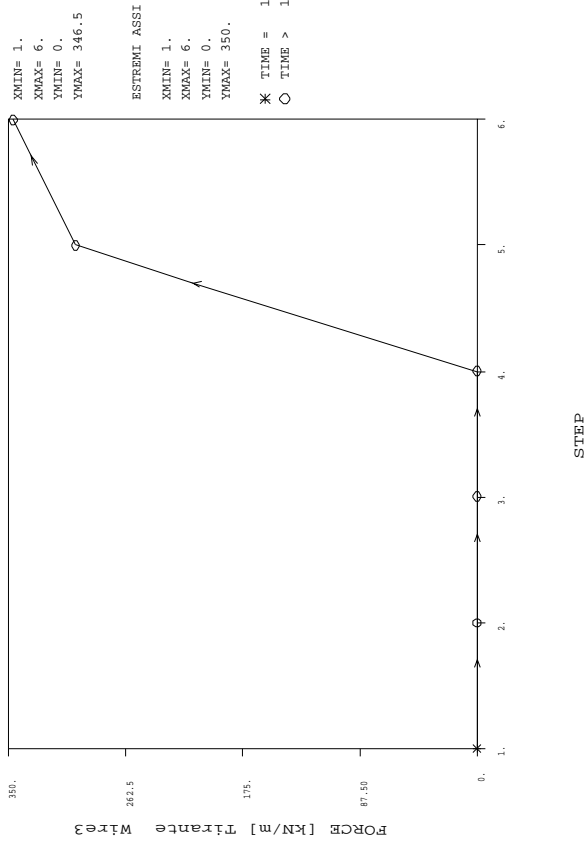

DAL PASSO 1 AL PASSO 6
DIAGRAMMA VARIABILE X / VARIABILE Y

HERSCY 0 - OMERSIS

URI: C:\Users\Tromba\Documents\cattella_11\Bella_Bualla_Ommeris_Foto_Geom\IACSE_AUG181_180m_1432011

Force unit= KN
Length unit= M

* Ce.A.S. S.r.l. Milano *
www.ceas.it
P A R A T I E 7.00
15 NOVEMBRE 2011 18:05:45

PARATIE 7.00
15 NOVEMBRE 2011 18:06:08
History 0 - ORMENIS

Ce.A.S. s.r.l. - Milano

PAG. 1

```
*****  
**  
**          P    A    R    A    T    I    E          **  
**  
**          RELEASE 7.00   VERSIONE WIN          **  
**  
** Ce.A.S. s.r.l. - Viale Giustiniano, 10      **  
**                               20129 MILANO    **  
**  
*****
```

JOBNAME C:\Users\Tecnico5\Desktop\Nuova cartella (3)\File Paratie Ormenis L

15 NOVEMBRE 2011 18:06:08

15 NOVEMBRE 2011 18:06:08

History 0 - ORMENIS

ELENCO DEI DATI DI INPUT(PARAGEN)

Per il significato dei vari comandi
si faccia riferimento al manuale di
input PARAGEN, versione 7.00.

N. comando

```
1: * Paratie for Windows version 7.0
2: * Filename= <c:\users\tecnico5\desktop\nuova cartella (3)\ormenis lato
  ormenis\s
3: * project with "run time" parameters
4: * Force=kN Lenght=m
5: *
6: units m kN
7: title History 0 - ORMENIS
8: delta 0.2
9: option param itemax 20
10: option noprint echo
11: option noprint displ
12: option noprint react
13: option noprint stresses
14:   wall RightWall 0 -30 0
15: *
16: soil DHRight RightWall -30 0 2 0
17: soil UHRight RightWall -30 0 1 180
18: *
19: prescribe RightWall -15.2 1 0 REL 9 9
20: *
21: material Pali 3.2308E+007
22: material Acciaio 2.1E+008
23: *
24: beam Right_wall RightWall -28 0 Pali 0.979439 00 00
25: *
26: wire Wire01 RightWall -0.5 Acciaio 2.87179E-005 150 157.5
27: wire Wire2 RightWall -4 Acciaio 4.30769E-005 150 157.5
28: wire Wire3 RightWall -8 Acciaio 4.30769E-005 300 157.5
29: wire Wire4 RightWall -12 Acciaio 4.30769E-005 300 157.5
30: *
31: * Soil Profile
32: *
33:   ldata      Soil 0
34:     weight   19 9 10
35:     atrest   1 0.5 1
36:     resistance 0 25 0.359 3.319
37:     young    18000 23000
38:   endlayer
```

PARATIE 7.00
15 NOVEMBRE 2011 18:06:08
History 0 - ORMENIS

Ce.A.S. s.r.l. - Milano

PAG. 3

N. comando

```
39:      ldata      Soil2 -5
40:          weight  21 11 10
41:          atrest  1 0.5 1
42:          resistance 20 28 0.317 3.929
43:          young   20000 25000
44:      endlayer
45:      ldata      Soil3 -15
46:          weight  21 11 10
47:          atrest  1 0.5 1
48:          resistance 40 28 0.317 3.929
49:          young   30000 35000
50:      endlayer
51: *
52: step 1 :
53:     setwall RightWall
54:         geom 0 -0.5
55:         add Wire01
56: endstep
57: *
58: step 2 :
59:     setwall RightWall
60:         geom 0 -4
61:         water -2 2
62: endstep
63: *
64: step 3 :
65:     setwall RightWall
66:         add Wire2
67: endstep
68: *
69: step 4 :
70:     setwall RightWall
71:         geom 0 -8.5
72:         water -2 6.5
73: endstep
74: *
75: step 5 :
76:     setwall RightWall
77:         add Wire3
78: endstep
79: *
80: step 6 :
81:     setwall RightWall
82:         geom 0 -12.5
83:         water -2 10.5
84: endstep
```

PARATIE 7.00
15 NOVEMBRE 2011 18:06:08
History 0 - ORMENIS

Ce.A.S. s.r.l. - Milano

PAG. 4

N. comando

```
85: *
86: step 7 :
87:     setwall RightWall
88:         geom 0 -12.5
89:         water -2 10.5
90:         add Wire4
91: endstep
92: *
93: step 8 :
94:     setwall RightWall
95:         geom 0 -15.3
96:         water -2 13.3
97:         surcharge 0 0 0 0
98: endstep
99: *
100: step 9 :
101:     setwall RightWall
102:         geom 0 -15.3
103:         water -2 13.3
104:         surcharge 23 0 0 0
105: endstep
106: *
107: *
```

RIASSUNTO PARAMETRI GEOTECNICI PER LA FASE 1

LAYER Soil

natura 1=granulare, 2=argilla	=	1.0000		
quota superiore	=	0.0000	m	
quota inferiore	=	-5.0000	m	
peso fuori falda	=	19.000	kN/m ³	
peso efficace in falda	=	9.0000	kN/m ³	
peso dell'acqua	=	10.000	kN/m ³	
angolo di attrito	=	25.000	DEG	(A MONTE)
coeff. spinta attiva ka	=	0.35900		(A MONTE)
coeff. spinta passiva kp	=	3.3190		(A MONTE)
Konc normal consolidato	=	1.0000		
esponente di OCR	=	0.50000		
OCR: grado di sovraconsolidazione	=	1.0000		
modello di rigidezza	=	1.0000		
modulo el. compr. vergine	=	18000.	kPa	
modulo el. scarico/ricarico	=	23000.	kPa	
natura 1=granulare, 2=argilla	=	1.0000		(A VALLE)
angolo di attrito	=	25.000	DEG	(A VALLE)
coeff. spinta attiva ka	=	0.35900		(A VALLE)
coeff. spinta passiva kp	=	3.3190		(A VALLE)

LAYER Soil2

natura 1=granulare, 2=argilla	=	1.0000		
quota superiore	=	-5.0000	m	
quota inferiore	=	-15.000	m	
peso fuori falda	=	21.000	kN/m ³	
peso efficace in falda	=	11.000	kN/m ³	
peso dell'acqua	=	10.000	kN/m ³	
coesione	=	20.000	kPa	(A MONTE)
angolo di attrito	=	28.000	DEG	(A MONTE)
coeff. spinta attiva ka	=	0.31700		(A MONTE)
coeff. spinta passiva kp	=	3.9290		(A MONTE)
Konc normal consolidato	=	1.0000		
esponente di OCR	=	0.50000		
OCR: grado di sovraconsolidazione	=	1.0000		
modello di rigidezza	=	1.0000		
modulo el. compr. vergine	=	20000.	kPa	
modulo el. scarico/ricarico	=	25000.	kPa	
natura 1=granulare, 2=argilla	=	1.0000		(A VALLE)
coesione	=	20.000	kPa	(A VALLE)
angolo di attrito	=	28.000	DEG	(A VALLE)
coeff. spinta attiva ka	=	0.31700		(A VALLE)

RIASSUNTO PARAMETRI GEOTECNICI PER LA FASE 1

coeff. spinta passiva kp = 3.9290 (A VALLE)

LAYER Soil3

natura 1=granulare, 2=argilla = 1.0000
quota superiore = -15.000 m
quota inferiore = -0.10000E+31 m
peso fuori falda = 21.000 kN/m³
peso efficace in falda = 11.000 kN/m³
peso dell'acqua = 10.000 kN/m³
coesione = 40.000 kPa (A MONTE)
angolo di attrito = 28.000 DEG (A MONTE)
coeff. spinta attiva ka = 0.31700 (A MONTE)
coeff. spinta passiva kp = 3.9290 (A MONTE)
Konc normal consolidato = 1.0000
esponente di OCR = 0.50000
OCR: grado di sovraconsolidazione = 1.0000
modello di rigidezza = 1.0000
modulo el. compr. vergine = 30000. kPa
modulo el. scarico/ricarico = 35000. kPa
natura 1=granulare, 2=argilla = 1.0000 (A VALLE)
coesione = 40.000 kPa (A VALLE)
angolo di attrito = 28.000 DEG (A VALLE)
coeff. spinta attiva ka = 0.31700 (A VALLE)
coeff. spinta passiva kp = 3.9290 (A VALLE)

RIASSUNTO PARAMETRI GEOTECNICI PER LA FASE 2

(SOLO I PARAMETRI CHE POSSONO VARIARE)

NESSUN CAMBIAMENTO RISPETTO AL PASSO PRECEDENTE

RIASSUNTO PARAMETRI GEOTECNICI PER LA FASE 3

(SOLO I PARAMETRI CHE POSSONO VARIARE)

NESSUN CAMBIAMENTO RISPETTO AL PASSO PRECEDENTE

RIASSUNTO PARAMETRI GEOTECNICI PER LA FASE 4

(SOLO I PARAMETRI CHE POSSONO VARIARE)

NESSUN CAMBIAMENTO RISPETTO AL PASSO PRECEDENTE

RIASSUNTO PARAMETRI GEOTECNICI PER LA FASE 5

(SOLO I PARAMETRI CHE POSSONO VARIARE)

PARATIE 7.00
15 NOVEMBRE 2011 18:06:08
History 0 - ORMENIS

Ce.A.S. s.r.l. - Milano

PAG. 7

NESSUN CAMBIAMENTO RISPETTO AL PASSO PRECEDENTE

RIASSUNTO PARAMETRI GEOTECNICI PER LA FASE 6

(SOLO I PARAMETRI CHE POSSONO VARIARE)

NESSUN CAMBIAMENTO RISPETTO AL PASSO PRECEDENTE

RIASSUNTO PARAMETRI GEOTECNICI PER LA FASE 7

(SOLO I PARAMETRI CHE POSSONO VARIARE)

NESSUN CAMBIAMENTO RISPETTO AL PASSO PRECEDENTE

RIASSUNTO PARAMETRI GEOTECNICI PER LA FASE 8

(SOLO I PARAMETRI CHE POSSONO VARIARE)

NESSUN CAMBIAMENTO RISPETTO AL PASSO PRECEDENTE

RIASSUNTO PARAMETRI GEOTECNICI PER LA FASE 9

(SOLO I PARAMETRI CHE POSSONO VARIARE)

NESSUN CAMBIAMENTO RISPETTO AL PASSO PRECEDENTE

RIASSUNTO DATI RELATIVI ALLA FASE 1

WALL RightWall

coordinata y	=	0.0000	m
quota piano campagna	=	0.0000	m
quota del fondo scavo	=	-0.50000	m
quota della falda	=	-0.99900E+30	m
sovraccarico a monte	=	0.0000	kPa
quota del sovraccarico a monte	=	0.0000	m
depressione falda a valle	=	0.0000	m
sovraccarico a valle	=	0.0000	kPa
quota del sovraccarico a valle	=	-0.99900E+30	m
quota di taglio	=	0.0000	m
quota di equil. pressioni dell'acqua	=	-30.000	m
indicatore comportamento acqua	=	0.0000	(1=REMOVE)
opzione aggiornamento pressioni acqua	=	0.0000	(1=NO UPD)

RIASSUNTO DATI RELATIVI ALLA FASE 2

WALL RightWall

coordinata y	=	0.0000	m
quota piano campagna	=	0.0000	m
quota del fondo scavo	=	-4.0000	m
quota della falda	=	-2.0000	m
sovraccarico a monte	=	0.0000	kPa
quota del sovraccarico a monte	=	0.0000	m
depressione falda a valle	=	2.0000	m
sovraccarico a valle	=	0.0000	kPa
quota del sovraccarico a valle	=	-0.99900E+30	m
quota di taglio	=	0.0000	m
quota di equil. pressioni dell'acqua	=	-30.000	m
indicatore comportamento acqua	=	0.0000	(1=REMOVE)
opzione aggiornamento pressioni acqua	=	0.0000	(1=NO UPD)

RIASSUNTO DATI RELATIVI ALLA FASE 3

WALL RightWall

coordinata y	=	0.0000	m
quota piano campagna	=	0.0000	m
quota del fondo scavo	=	-4.0000	m
quota della falda	=	-2.0000	m
sovraccarico a monte	=	0.0000	kPa

RIASSUNTO DATI RELATIVI ALLA FASE 3

quota del sovraccarico a monte	= 0.0000	m
depressione falda a valle	= 2.0000	m
sovraccarico a valle	= 0.0000	kPa
quota del sovraccarico a valle	= -0.99900E+30	m
quota di taglio	= 0.0000	m
quota di equil. pressioni dell'acqua	= -30.0000	m
indicatore comportamento acqua	= 0.0000	(1=REMOVE)
opzione aggiornamento pressioni acqua	= 0.0000	(1=NO UPD)

RIASSUNTO DATI RELATIVI ALLA FASE 4

WALL RightWall

coordinata y	= 0.0000	m
quota piano campagna	= 0.0000	m
quota del fondo scavo	= -8.5000	m
quota della falda	= -2.0000	m
sovraccarico a monte	= 0.0000	kPa
quota del sovraccarico a monte	= 0.0000	m
depressione falda a valle	= 6.5000	m
sovraccarico a valle	= 0.0000	kPa
quota del sovraccarico a valle	= -0.99900E+30	m
quota di taglio	= 0.0000	m
quota di equil. pressioni dell'acqua	= -30.0000	m
indicatore comportamento acqua	= 0.0000	(1=REMOVE)
opzione aggiornamento pressioni acqua	= 0.0000	(1=NO UPD)

RIASSUNTO DATI RELATIVI ALLA FASE 5

WALL RightWall

coordinata y	= 0.0000	m
quota piano campagna	= 0.0000	m
quota del fondo scavo	= -8.5000	m
quota della falda	= -2.0000	m
sovraccarico a monte	= 0.0000	kPa
quota del sovraccarico a monte	= 0.0000	m
depressione falda a valle	= 6.5000	m
sovraccarico a valle	= 0.0000	kPa
quota del sovraccarico a valle	= -0.99900E+30	m
quota di taglio	= 0.0000	m
quota di equil. pressioni dell'acqua	= -30.0000	m
indicatore comportamento acqua	= 0.0000	(1=REMOVE)
opzione aggiornamento pressioni acqua	= 0.0000	(1=NO UPD)

RIASSUNTO DATI RELATIVI ALLA FASE 6

WALL RightWall

coordinata y	=	0.0000	m
quota piano campagna	=	0.0000	m
quota del fondo scavo	=	-12.500	m
quota della falda	=	-2.0000	m
sovraccarico a monte	=	0.0000	kPa
quota del sovraccarico a monte	=	0.0000	m
depressione falda a valle	=	10.500	m
sovraccarico a valle	=	0.0000	kPa
quota del sovraccarico a valle	=	-0.99900E+30	m
quota di taglio	=	0.0000	m
quota di equil. pressioni dell'acqua	=	-30.000	m
indicatore comportamento acqua	=	0.0000	(1=REMOVE)
opzione aggiornamento pressioni acqua	=	0.0000	(1=NO UPD)

RIASSUNTO DATI RELATIVI ALLA FASE 7

WALL RightWall

coordinata y	=	0.0000	m
quota piano campagna	=	0.0000	m
quota del fondo scavo	=	-12.500	m
quota della falda	=	-2.0000	m
sovraccarico a monte	=	0.0000	kPa
quota del sovraccarico a monte	=	0.0000	m
depressione falda a valle	=	10.500	m
sovraccarico a valle	=	0.0000	kPa
quota del sovraccarico a valle	=	-0.99900E+30	m
quota di taglio	=	0.0000	m
quota di equil. pressioni dell'acqua	=	-30.000	m
indicatore comportamento acqua	=	0.0000	(1=REMOVE)
opzione aggiornamento pressioni acqua	=	0.0000	(1=NO UPD)

RIASSUNTO DATI RELATIVI ALLA FASE 8

WALL RightWall

coordinata y	=	0.0000	m
quota piano campagna	=	0.0000	m
quota del fondo scavo	=	-15.300	m
quota della falda	=	-2.0000	m
sovraccarico a monte	=	0.0000	kPa
quota del sovraccarico a monte	=	0.0000	m
depressione falda a valle	=	13.300	m
sovraccarico a valle	=	0.0000	kPa

PARATIE 7.00

Ce.A.S. s.r.l. - Milano

PAG. 11

15 NOVEMBRE 2011 18:06:08

History 0 - ORMENIS

RIASSUNTO DATI RELATIVI ALLA FASE 8

quota del sovraccarico a valle	= 0.0000	m
quota di taglio	= 0.0000	m
quota di equil. pressioni dell'acqua	= -30.000	m
indicatore comportamento acqua	= 0.0000	(1=REMOVE)
opzione aggiornamento pressioni acqua	= 0.0000	(1=NO UPD)

RIASSUNTO DATI RELATIVI ALLA FASE 9

WALL RightWall

coordinata y	= 0.0000	m
quota piano campagna	= 0.0000	m
quota del fondo scavo	= -15.300	m
quota della falda	= -2.0000	m
sovraccarico a monte	= 23.000	kPa
quota del sovraccarico a monte	= 0.0000	m
depressione falda a valle	= 13.300	m
sovraccarico a valle	= 0.0000	kPa
quota del sovraccarico a valle	= 0.0000	m
quota di taglio	= 0.0000	m
quota di equil. pressioni dell'acqua	= -30.000	m
indicatore comportamento acqua	= 0.0000	(1=REMOVE)
opzione aggiornamento pressioni acqua	= 0.0000	(1=NO UPD)

RIASSUNTO ELEMENTI

=====

RIASSUNTO ELEMENTI SOIL						
Name	Wall	Z1	Z2	Flag	Angle	
		m	m		deg	
DHRight	RightWall	0.	-30.00	DOWNHILL	0.	
UHRight	RightWall	0.	-30.00	UPHILL	180.0	

RIASSUNTO ELEMENTI BEAM						
Name	Wall	Z1	Z2	Mat	thick	
		m	m		m	
Right_wall	RightWall	0.	-28.00	_	0.9794	

RIASSUNTO ELEMENTI WIRE						
Name	Wall	Zeta	Mat	A/L	Pinit	Angle
		m			kN/m	deg
Wire01	RightWall	-5.000	_	0.2872E-04	150.0	157.5
Wire2	RightWall	-4.000	_	0.4308E-04	150.0	157.5
Wire3	RightWall	-8.000	_	0.4308E-04	300.0	157.5
Wire4	RightWall	-12.00	_	0.4308E-04	300.0	157.5

PARATIE 7.00
15 NOVEMBRE 2011 18:06:08
History 0 - ORMENIS

Ce.A.S. s.r.l. - Milano

PAG. 13

RIASSUNTO DATI VARI
=====

MATERIALI	
Name	YOUNG MODULUS
	kPa
Pali	3.2308E+007
Acci	2.1E+008

SPOSTAMENTI IMPRESSI							
Wall	Zeta	Dir.	type	value	units	step	to
Righ	-15.2	ydispl	REL	0	m	9	9

PARATIE 7.00

Ce.A.S. s.r.l. - Milano

PAG. 14

15 NOVEMBRE 2011 18:06:08

History 0 - ORMENIS

RIASSUNTO ANALISI INCREMENTALE

FASE	N. DI ITERAZIONI	CONVERGENZA
1	3	SI
2	3	SI
3	3	SI
4	2	SI
5	2	SI
6	3	SI
7	2	SI
8	3	SI
9	2	SI

MASSIMI SPOSTAMENTI LATERALI

TUTTI I PASSI

* PARETE RightWall*

* I PASSI NON EQUILIBRATI SONO ESCLUSI *

* NOTA: LE QUOTE ESPRESSE IN m

E GLI SPOSTAMENTI IN m

NODO	QUOTA ZETA	SPOSTAMENTO MASSIMO	FASE PARETE RightWall
1	0.0000	0.82064E-02	8
2	-0.20000	0.72505E-02	8
3	-0.40000	0.62946E-02	8
4	-0.50000	0.58167E-02	8
5	-0.70000	0.48608E-02	8
6	-0.90000	0.39053E-02	8
7	-1.1000	0.29505E-02	8
8	-1.3000	-0.33052E-02	4
9	-1.5000	-0.39592E-02	9
10	-1.7000	-0.48228E-02	9
11	-1.9000	-0.56843E-02	9
12	-2.1000	-0.65435E-02	9
13	-2.3000	-0.74002E-02	9
14	-2.5000	-0.82540E-02	9
15	-2.7000	-0.91050E-02	9
16	-2.9000	-0.99529E-02	9
17	-3.1000	-0.10798E-01	9
18	-3.3000	-0.11639E-01	9
19	-3.5000	-0.12478E-01	9
20	-3.7000	-0.13313E-01	9
21	-3.9000	-0.14145E-01	9
22	-4.0000	-0.14560E-01	9
23	-4.2000	-0.15387E-01	9
24	-4.4000	-0.16210E-01	9
25	-4.6000	-0.17029E-01	9
26	-4.8000	-0.17844E-01	9
27	-5.0000	-0.18653E-01	9
28	-5.2000	-0.19456E-01	9
29	-5.4000	-0.20253E-01	9
30	-5.6000	-0.21043E-01	9
31	-5.8000	-0.21826E-01	9
32	-6.0000	-0.22602E-01	9
33	-6.2000	-0.23370E-01	9
34	-6.4000	-0.24130E-01	9
35	-6.6000	-0.24883E-01	9
36	-6.8000	-0.25626E-01	9
37	-7.0000	-0.26362E-01	9
38	-7.2000	-0.27088E-01	9

PARATIE 7.00

Ce.A.S. s.r.l. - Milano

PAG. 16

15 NOVEMBRE 2011 18:06:08

History 0 - ORMENIS

NODO	QUOTA ZETA	SPOSTAMENTO MASSIMO	FASE PARETE RightWall
39	-7.4000	-0.27807E-01	9
40	-7.6000	-0.28516E-01	9
41	-7.8000	-0.29217E-01	9
42	-8.0000	-0.29910E-01	9
43	-8.2000	-0.30595E-01	9
44	-8.4000	-0.31270E-01	9
45	-8.6000	-0.31935E-01	9
46	-8.8000	-0.32588E-01	9
47	-9.0000	-0.33230E-01	9
48	-9.2000	-0.33858E-01	9
49	-9.4000	-0.34473E-01	9
50	-9.6000	-0.35073E-01	9
51	-9.8000	-0.35658E-01	9
52	-10.000	-0.36228E-01	9
53	-10.200	-0.36781E-01	9
54	-10.400	-0.37317E-01	9
55	-10.600	-0.37837E-01	9
56	-10.800	-0.38339E-01	9
57	-11.000	-0.38824E-01	9
58	-11.200	-0.39291E-01	9
59	-11.400	-0.39740E-01	9
60	-11.600	-0.40172E-01	9
61	-11.800	-0.40587E-01	9
62	-12.000	-0.40984E-01	9
63	-12.200	-0.41364E-01	9
64	-12.400	-0.41727E-01	9
65	-12.600	-0.42071E-01	9
66	-12.800	-0.42396E-01	9
67	-13.000	-0.42702E-01	9
68	-13.200	-0.42989E-01	9
69	-13.400	-0.43256E-01	9
70	-13.600	-0.43502E-01	9
71	-13.800	-0.43729E-01	9
72	-14.000	-0.43936E-01	9
73	-14.200	-0.44123E-01	9
74	-14.400	-0.44292E-01	9
75	-14.600	-0.44441E-01	9
76	-14.800	-0.44572E-01	9
77	-15.000	-0.44686E-01	9
78	-15.200	-0.44783E-01	9
79	-15.400	-0.44870E-01	8
80	-15.600	-0.44937E-01	8
81	-15.800	-0.44985E-01	8
82	-16.000	-0.45022E-01	9
83	-16.200	-0.45047E-01	9
84	-16.400	-0.45060E-01	9

PARATIE 7.00

Ce.A.S. s.r.l. - Milano

PAG. 17

15 NOVEMBRE 2011 18:06:08

History 0 - ORMENIS

NODO	QUOTA ZETA	SPOSTAMENTO MASSIMO	FASE PARETE RightWall
85	-16.600	-0.45060E-01	9
86	-16.800	-0.45048E-01	9
87	-17.000	-0.45026E-01	9
88	-17.200	-0.44992E-01	9
89	-17.400	-0.44949E-01	9
90	-17.600	-0.44896E-01	9
91	-17.800	-0.44834E-01	9
92	-18.000	-0.44764E-01	9
93	-18.200	-0.44685E-01	9
94	-18.400	-0.44599E-01	9
95	-18.600	-0.44506E-01	9
96	-18.800	-0.44405E-01	9
97	-19.000	-0.44299E-01	9
98	-19.200	-0.44186E-01	9
99	-19.400	-0.44068E-01	9
100	-19.600	-0.43944E-01	9
101	-19.800	-0.43816E-01	9
102	-20.000	-0.43683E-01	9
103	-20.200	-0.43546E-01	9
104	-20.400	-0.43405E-01	9
105	-20.600	-0.43260E-01	9
106	-20.800	-0.43112E-01	9
107	-21.000	-0.42961E-01	9
108	-21.200	-0.42807E-01	9
109	-21.400	-0.42650E-01	9
110	-21.600	-0.42491E-01	9
111	-21.800	-0.42330E-01	9
112	-22.000	-0.42166E-01	9
113	-22.200	-0.42001E-01	9
114	-22.400	-0.41835E-01	9
115	-22.600	-0.41667E-01	9
116	-22.800	-0.41497E-01	9
117	-23.000	-0.41327E-01	9
118	-23.200	-0.41155E-01	9
119	-23.400	-0.40982E-01	9
120	-23.600	-0.40809E-01	9
121	-23.800	-0.40635E-01	9
122	-24.000	-0.40461E-01	9
123	-24.200	-0.40285E-01	9
124	-24.400	-0.40110E-01	9
125	-24.600	-0.39934E-01	9
126	-24.800	-0.39758E-01	9
127	-25.000	-0.39581E-01	9
128	-25.200	-0.39404E-01	9
129	-25.400	-0.39228E-01	9
130	-25.600	-0.39050E-01	9

PARATIE 7.00

Ce.A.S. s.r.l. - Milano

PAG. 18

15 NOVEMBRE 2011 18:06:08

History 0 - ORMENIS

NODO	QUOTA ZETA	SPOSTAMENTO MASSIMO	FASE PARETE	RightWall
131	-25.800	-0.38873E-01	9	
132	-26.000	-0.38696E-01	9	
133	-26.200	-0.38519E-01	9	
134	-26.400	-0.38342E-01	9	
135	-26.600	-0.38164E-01	9	
136	-26.800	-0.37987E-01	9	
137	-27.000	-0.37810E-01	9	
138	-27.200	-0.37632E-01	9	
139	-27.400	-0.37455E-01	9	
140	-27.600	-0.37278E-01	9	
141	-27.800	-0.37100E-01	9	
142	-28.000	-0.36923E-01	9	
143	-28.200	-0.36164E-01	9	
144	-28.400	-0.36081E-01	9	
145	-28.600	-0.35997E-01	9	
146	-28.800	-0.35915E-01	9	
147	-29.000	-0.35833E-01	9	
148	-29.200	-0.35752E-01	9	
149	-29.400	-0.35671E-01	9	
150	-29.600	-0.35591E-01	9	
151	-29.800	-0.35512E-01	9	
152	-30.000	-0.35433E-01	9	

PARATIE 7.00
15 NOVEMBRE 2011 18:06:08
History 0 - ORMENIS

Ce.A.S. s.r.l. - Milano

PAG. 19

STEP DI CARICO NO. 9

NOD	Y-REACT [kN/m]	X-MOM-R [kN*m/m]
78	0.16866278E+03	0.00000000E+00

INVILUPPO AZIONI INTERNE NEGLI ELEMENTI DI PARETE
 (PER UNITA' DI PROFONDITA')

* PARETE RightWall GRUPPO Right_wall*

STEP 1 - 9

* I PASSI NON EQUILIBRATI SONO ESCLUSI *

Nella tabella si stampano i seguenti risultati:

MOMENTO SX = Momento che tende le fibre sulla faccia sinistra [kN*m/m]

MOMENTO DX = Momento che tende le fibre sulla faccia destra [kN*m/m]

TAGLIO = forza tagliante (valore assoluto, priva di segno)[kN/m]

BEAM EL.	ESTREMO	QUOTA	MOMENTO SX	MOMENTO DX	TAGLIO
1	A	0.	0.4511E-09	0.3274E-10	1.279
	B	-0.2000	0.8731E-10	0.2559	1.279
2	A	-0.2000	0.2692E-09	0.2559	6.392
	B	-0.4000	0.	1.534	6.392
3	A	-0.4000	0.	1.534	11.97
	B	-0.5000	0.	2.731	11.97
4	A	-0.5000	0.	2.731	157.7
	B	-0.7000	31.20	0.	157.7
5	A	-0.7000	31.20	0.	154.6
	B	-0.9000	62.13	0.	154.6
6	A	-0.9000	62.13	0.	151.4
	B	-1.100	92.40	0.	151.4
7	A	-1.100	92.40	0.	147.8
	B	-1.300	122.0	0.	147.8
8	A	-1.300	122.0	0.	144.0
	B	-1.500	150.8	0.	144.0
9	A	-1.500	150.8	0.	139.9
	B	-1.700	178.7	0.	139.9
10	A	-1.700	178.7	0.	135.5
	B	-1.900	205.8	0.	135.5
11	A	-1.900	205.8	0.	130.9
	B	-2.100	232.0	0.	130.9
12	A	-2.100	232.0	0.	125.9
	B	-2.300	257.2	0.	125.9
13	A	-2.300	257.2	0.	120.4
	B	-2.500	281.3	0.	120.4
14	A	-2.500	281.3	0.	114.5
	B	-2.700	304.2	0.	114.5
15	A	-2.700	304.2	0.	108.1
	B	-2.900	325.8	0.	108.1
16	A	-2.900	325.8	0.	101.3
	B	-3.100	346.1	0.	101.3
17	A	-3.100	346.1	0.	93.94
	B	-3.300	364.9	0.	93.94

PARATIE 7.00

Ce.A.S. s.r.l. - Milano

PAG. 21

15 NOVEMBRE 2011 18:06:08

History 0 - ORMENIS

BEAM EL.	ESTREMO	QUOTA	MOMENTO SX	MOMENTO DX	TAGLIO
18	A	-3.300	364.9	0.	86.14
	B	-3.500	382.1	0.	86.14
19	A	-3.500	382.1	0.	77.86
	B	-3.700	397.7	0.	77.86
20	A	-3.700	397.7	0.	69.10
	B	-3.900	411.5	0.	69.10
21	A	-3.900	411.5	0.	62.15
	B	-4.000	417.7	0.	62.15
22	A	-4.000	417.7	0.	258.5
	B	-4.200	469.4	0.	258.5
23	A	-4.200	469.4	0.	248.5
	B	-4.400	519.1	0.	248.5
24	A	-4.400	519.1	0.	238.0
	B	-4.600	566.7	0.	238.0
25	A	-4.600	566.7	0.	227.0
	B	-4.800	612.1	0.	227.0
26	A	-4.800	612.1	0.	215.4
	B	-5.000	655.2	0.	215.4
27	A	-5.000	655.2	0.	204.7
	B	-5.200	696.1	0.	204.7
28	A	-5.200	696.1	0.	193.4
	B	-5.400	734.8	0.	193.4
29	A	-5.400	734.8	0.	181.6
	B	-5.600	771.1	0.	181.6
30	A	-5.600	771.1	0.	169.1
	B	-5.800	805.0	0.	169.1
31	A	-5.800	805.0	0.	156.1
	B	-6.000	836.2	0.	156.1
32	A	-6.000	836.2	0.	142.4
	B	-6.200	864.7	0.	142.4
33	A	-6.200	864.7	0.	128.1
	B	-6.400	890.3	0.	128.1
34	A	-6.400	890.3	0.	113.2
	B	-6.600	912.9	0.	113.2
35	A	-6.600	912.9	0.	97.64
	B	-6.800	932.4	0.	97.64
36	A	-6.800	932.4	0.	81.42
	B	-7.000	948.7	0.	81.42
37	A	-7.000	948.7	0.	66.31
	B	-7.200	961.6	0.	66.31
38	A	-7.200	961.6	0.	66.94
	B	-7.400	971.0	0.	66.94
39	A	-7.400	971.0	0.	88.27
	B	-7.600	976.7	0.	88.27
40	A	-7.600	976.7	0.	110.3
	B	-7.800	978.7	0.	110.3

PARATIE 7.00

Ce.A.S. s.r.l. - Milano

PAG. 22

15 NOVEMBRE 2011 18:06:08

History 0 - ORMENIS

BEAM EL.	ESTREMO	QUOTA	MOMENTO SX	MOMENTO DX	TAGLIO
41	A	-7.800	978.7	0.	133.1
	B	-8.000	976.6	0.	133.1
42	A	-8.000	976.6	0.	371.2
	B	-8.200	970.5	0.	371.2
43	A	-8.200	970.5	0.	354.3
	B	-8.400	960.1	0.	354.3
44	A	-8.400	960.1	0.	336.8
	B	-8.600	1024.	0.	336.8
45	A	-8.600	1024.	0.	318.7
	B	-8.800	1088.	0.	318.7
46	A	-8.800	1088.	0.	300.0
	B	-9.000	1148.	0.	300.0
47	A	-9.000	1148.	0.	280.8
	B	-9.200	1204.	0.	280.8
48	A	-9.200	1204.	0.	260.8
	B	-9.400	1256.	0.	260.8
49	A	-9.400	1256.	0.	240.2
	B	-9.600	1304.	0.	240.2
50	A	-9.600	1304.	0.	219.0
	B	-9.800	1348.	0.	219.0
51	A	-9.800	1348.	0.	197.0
	B	-10.00	1387.	0.	197.0
52	A	-10.00	1387.	0.	174.4
	B	-10.20	1422.	0.	174.4
53	A	-10.20	1422.	0.	151.0
	B	-10.40	1452.	0.	151.0
54	A	-10.40	1452.	0.	126.9
	B	-10.60	1478.	0.	126.9
55	A	-10.60	1478.	0.	121.5
	B	-10.80	1498.	0.	121.5
56	A	-10.80	1498.	0.	123.2
	B	-11.00	1513.	0.	123.2
57	A	-11.00	1513.	0.	124.7
	B	-11.20	1523.	0.	124.7
58	A	-11.20	1523.	0.	126.1
	B	-11.40	1528.	0.	126.1
59	A	-11.40	1528.	0.	127.3
	B	-11.60	1527.	0.	127.3
60	A	-11.60	1527.	0.	155.3
	B	-11.80	1520.	0.	155.3
61	A	-11.80	1520.	0.	187.5
	B	-12.00	1507.	0.	187.5
62	A	-12.00	1507.	0.	276.8
	B	-12.20	1488.	0.	276.8
63	A	-12.20	1488.	0.	248.1
	B	-12.40	1463.	0.	248.1

BEAM EL.	ESTREMO	QUOTA	MOMENTO SX	MOMENTO DX	TAGLIO
64	A	-12.40	1463.	0.	218.7
	B	-12.60	1431.	0.	218.7
65	A	-12.60	1431.	0.	188.5
	B	-12.80	1396.	0.	188.5
66	A	-12.80	1396.	0.	190.8
	B	-13.00	1419.	0.	190.8
67	A	-13.00	1419.	0.	205.6
	B	-13.20	1444.	0.	205.6
68	A	-13.20	1444.	0.	219.5
	B	-13.40	1463.	0.	219.5
69	A	-13.40	1463.	0.	232.5
	B	-13.60	1474.	0.	232.5
70	A	-13.60	1474.	0.	244.6
	B	-13.80	1479.	0.	244.6
71	A	-13.80	1479.	0.	255.9
	B	-14.00	1477.	0.	255.9
72	A	-14.00	1477.	0.	266.4
	B	-14.20	1468.	0.	266.4
73	A	-14.20	1468.	0.	276.0
	B	-14.40	1451.	0.	276.0
74	A	-14.40	1451.	0.	284.8
	B	-14.60	1427.	0.	284.8
75	A	-14.60	1427.	0.	292.8
	B	-14.80	1395.	1.214	292.8
76	A	-14.80	1395.	1.214	300.1
	B	-15.00	1355.	9.389	300.1
77	A	-15.00	1355.	9.389	310.3
	B	-15.20	1308.	16.86	310.3
78	A	-15.20	1308.	16.86	278.0
	B	-15.40	1256.	23.67	278.0
79	A	-15.40	1256.	23.67	267.0
	B	-15.60	1204.	29.83	267.0
80	A	-15.60	1204.	29.83	258.6
	B	-15.80	1152.	35.39	258.6
81	A	-15.80	1152.	35.39	256.1
	B	-16.00	1101.	40.36	256.1
82	A	-16.00	1101.	40.36	252.7
	B	-16.20	1051.	44.78	252.7
83	A	-16.20	1051.	44.78	248.7
	B	-16.40	1001.	48.68	248.7
84	A	-16.40	1001.	48.68	243.9
	B	-16.60	952.2	52.08	243.9
85	A	-16.60	952.2	52.08	238.4
	B	-16.80	904.5	55.01	238.4
86	A	-16.80	904.5	55.01	232.5
	B	-17.00	858.0	57.51	232.5

PARATIE 7.00

Ce.A.S. s.r.l. - Milano

PAG. 24

15 NOVEMBRE 2011 18:06:08

History 0 - ORMENIS

BEAM EL.	ESTREMO	QUOTA	MOMENTO SX	MOMENTO DX	TAGLIO
87	A	-17.00	858.0	57.51	226.3
	B	-17.20	812.8	69.11	226.3
88	A	-17.20	812.8	69.11	219.9
	B	-17.40	768.8	80.49	219.9
89	A	-17.40	768.8	80.49	213.3
	B	-17.60	726.1	90.71	213.3
90	A	-17.60	726.1	90.71	206.7
	B	-17.80	684.8	99.81	206.7
91	A	-17.80	684.8	99.81	199.9
	B	-18.00	644.8	107.8	199.9
92	A	-18.00	644.8	107.8	193.0
	B	-18.20	606.2	114.9	193.0
93	A	-18.20	606.2	114.9	186.1
	B	-18.40	569.0	120.9	186.1
94	A	-18.40	569.0	120.9	179.2
	B	-18.60	533.2	126.1	179.2
95	A	-18.60	533.2	126.1	172.2
	B	-18.80	498.7	130.4	172.2
96	A	-18.80	498.7	130.4	165.3
	B	-19.00	465.6	133.8	165.3
97	A	-19.00	465.6	133.8	158.5
	B	-19.20	434.0	136.5	158.5
98	A	-19.20	434.0	136.5	151.6
	B	-19.40	403.6	138.4	151.6
99	A	-19.40	403.6	138.4	144.9
	B	-19.60	374.7	139.7	144.9
100	A	-19.60	374.7	139.7	138.2
	B	-19.80	347.0	140.3	138.2
101	A	-19.80	347.0	140.3	131.6
	B	-20.00	320.7	140.3	131.6
102	A	-20.00	320.7	140.3	125.2
	B	-20.20	295.6	139.7	125.2
103	A	-20.20	295.6	139.7	118.8
	B	-20.40	271.9	138.6	118.8
104	A	-20.40	271.9	138.6	112.5
	B	-20.60	249.4	137.0	112.5
105	A	-20.60	249.4	137.0	106.4
	B	-20.80	228.1	135.0	106.4
106	A	-20.80	228.1	135.0	100.4
	B	-21.00	208.0	132.5	100.4
107	A	-21.00	208.0	132.5	94.58
	B	-21.20	189.1	129.7	94.58
108	A	-21.20	189.1	129.7	88.88
	B	-21.40	171.3	126.5	88.88
109	A	-21.40	171.3	126.5	83.32
	B	-21.60	154.6	122.9	83.32

PARATIE 7.00

Ce.A.S. s.r.l. - Milano

PAG. 25

15 NOVEMBRE 2011 18:06:08

History 0 - ORMENIS

BEAM EL.	ESTREMO	QUOTA	MOMENTO SX	MOMENTO DX	TAGLIO
110	A	-21.60	154.6	122.9	77.92
	B	-21.80	139.1	119.1	77.92
111	A	-21.80	139.1	119.1	72.68
	B	-22.00	124.5	115.1	72.68
112	A	-22.00	124.5	115.1	67.60
	B	-22.20	111.0	110.8	67.60
113	A	-22.20	111.0	110.8	62.69
	B	-22.40	98.47	106.3	62.69
114	A	-22.40	98.47	106.3	57.94
	B	-22.60	86.88	101.7	57.94
115	A	-22.60	86.88	101.7	53.37
	B	-22.80	76.21	96.86	53.37
116	A	-22.80	76.21	96.86	48.97
	B	-23.00	66.41	91.95	48.97
117	A	-23.00	66.41	91.95	44.74
	B	-23.20	57.47	86.96	44.74
118	A	-23.20	57.47	86.96	40.69
	B	-23.40	50.33	81.90	40.69
119	A	-23.40	50.33	81.90	36.82
	B	-23.60	43.88	76.81	36.82
120	A	-23.60	43.88	76.81	33.14
	B	-23.80	38.01	71.70	33.14
121	A	-23.80	38.01	71.70	29.63
	B	-24.00	32.67	66.60	29.63
122	A	-24.00	32.67	66.60	26.31
	B	-24.20	27.85	61.54	26.31
123	A	-24.20	27.85	61.54	25.04
	B	-24.40	23.53	56.53	25.04
124	A	-24.40	23.53	56.53	24.64
	B	-24.60	19.67	52.65	24.64
125	A	-24.60	19.67	52.65	24.14
	B	-24.80	16.25	48.80	24.14
126	A	-24.80	16.25	48.80	23.53
	B	-25.00	13.24	44.82	23.53
127	A	-25.00	13.24	44.82	22.82
	B	-25.20	10.63	40.75	22.82
128	A	-25.20	10.63	40.75	22.00
	B	-25.40	8.379	36.65	22.00
129	A	-25.40	8.379	36.65	21.08
	B	-25.60	6.465	32.56	21.08
130	A	-25.60	6.465	32.56	20.21
	B	-25.80	4.861	28.52	20.21
131	A	-25.80	4.861	28.52	19.73
	B	-26.00	3.542	24.57	19.73
132	A	-26.00	3.542	24.57	19.04
	B	-26.20	2.481	20.76	19.04

PARATIE 7.00

15 NOVEMBRE 2011 18:06:08

History 0 - ORMENIS

Ce.A.S. s.r.l. - Milano

PAG. 26

BEAM EL.	ESTREMO	QUOTA	MOMENTO SX	MOMENTO DX	TAGLIO
133	A	-26.20	2.481	20.76	18.12
	B	-26.40	1.649	17.14	18.12
134	A	-26.40	1.649	17.14	16.99
	B	-26.60	1.021	13.74	16.99
135	A	-26.60	1.021	13.74	15.63
	B	-26.80	0.5692	10.61	15.63
136	A	-26.80	0.5692	10.61	14.06
	B	-27.00	0.2656	7.801	14.06
137	A	-27.00	0.2656	7.801	12.27
	B	-27.20	0.8277E-01	5.348	12.27
138	A	-27.20	0.8277E-01	5.348	10.25
	B	-27.40	0.	3.297	10.25
139	A	-27.40	0.	3.297	8.021
	B	-27.60	0.	1.693	8.021
140	A	-27.60	0.	1.693	5.568
	B	-27.80	0.	0.5790	5.568
141	A	-27.80	0.	0.5790	2.895
	B	-28.00	0.2161E-08	0.1899E-08	2.895

PARATIE 7.00
15 NOVEMBRE 2011 18:06:08
History 0 - ORMENIS

Ce.A.S. s.r.l. - Milano

PAG. 27

FORZE NEGLI ANCORAGGI ATTIVI (PER UNITA' DI PROFONDITA')

TIRANTE	Wire01	1 PARETE RightWall	QUOTA	-0.50000
		FASE 1 FORZA	150.00	kN/m
		FASE 2 FORZA	167.87	kN/m
		FASE 3 FORZA	156.60	kN/m
		FASE 4 FORZA	174.78	kN/m
		FASE 5 FORZA	163.54	kN/m
		FASE 6 FORZA	153.05	kN/m
		FASE 7 FORZA	153.69	kN/m
		FASE 8 FORZA	135.46	kN/m
		FASE 9 FORZA	165.76	kN/m
TIRANTE	Wire2	1 PARETE RightWall	QUOTA	-4.0000
		FASE 1 inattivo		
		FASE 2 inattivo		
		FASE 3 FORZA	150.00	kN/m
		FASE 4 FORZA	220.28	kN/m
		FASE 5 FORZA	192.14	kN/m
		FASE 6 FORZA	236.67	kN/m
		FASE 7 FORZA	221.37	kN/m
		FASE 8 FORZA	226.68	kN/m
		FASE 9 FORZA	259.26	kN/m
TIRANTE	Wire3	1 PARETE RightWall	QUOTA	-8.0000
		FASE 1 inattivo		
		FASE 2 inattivo		
		FASE 3 inattivo		
		FASE 4 inattivo		
		FASE 5 FORZA	300.00	kN/m
		FASE 6 FORZA	412.68	kN/m
		FASE 7 FORZA	379.83	kN/m
		FASE 8 FORZA	426.55	kN/m
		FASE 9 FORZA	444.50	kN/m
TIRANTE	Wire4	1 PARETE RightWall	QUOTA	-12.000
		FASE 1 inattivo		
		FASE 2 inattivo		
		FASE 3 inattivo		
		FASE 4 inattivo		
		FASE 5 inattivo		
		FASE 6 inattivo		
		FASE 7 FORZA	300.00	kN/m
		FASE 8 FORZA	392.20	kN/m
		FASE 9 FORZA	397.43	kN/m

INVILUPPO RISULTATI NEGLI ELEMENTI TERRENO

* PARETE RightWall GRUPPO DRight*

STEP 1 - 9

* I PASSI NON EQUILIBRATI SONO ESCLUSI *

Nella tabella si stampano i seguenti risultati:

SIGMA-H = massimo sforzo orizzontale efficace [kPa]

TAGLIO = massimo sforzo di taglio [kPa]

PR. ACQUA =massima pressione interstiziale [kPa]

GRAD. MAX =massimo gradiente idraulico

SOIL EL.	QUOTA	SIGMA-H	TAGLIO	PR. ACQUA	GRAD. MAX
1	0.	0.	0.	0.	0.
2	-0.2000	0.	0.	0.	0.
3	-0.4000	0.	0.	0.	0.
4	-0.5000	0.	0.	0.	0.
5	-0.7000	1.364	1.218	0.	0.
6	-0.9000	2.728	2.436	0.	0.
7	-1.100	4.093	3.654	0.	0.
8	-1.300	5.457	4.872	0.	0.
9	-1.500	6.821	6.089	0.	0.
10	-1.700	8.185	7.307	0.	0.
11	-1.900	10.53	8.036	0.	0.
12	-2.100	15.34	7.531	0.	0.
13	-2.300	20.13	7.035	0.	0.
14	-2.500	24.90	6.550	0.	0.
15	-2.700	29.65	6.075	0.	0.
16	-2.900	34.38	5.612	0.	0.
17	-3.100	39.08	5.160	0.	0.
18	-3.300	43.76	4.721	0.	0.
19	-3.500	48.41	4.295	0.	0.
20	-3.700	53.04	3.882	0.	0.
21	-3.900	57.63	3.483	0.	0.
22	-4.000	59.92	3.288	0.	0.
23	-4.200	64.48	2.909	2.074	0.3704E-01
24	-4.400	69.01	4.002	4.148	0.3704E-01
25	-4.600	73.51	6.004	6.222	0.3704E-01
26	-4.800	77.99	8.005	8.296	0.3704E-01
27	-5.000	82.36	19.33	10.37	0.3704E-01
28	-5.200	87.19	20.59	12.44	0.3704E-01
29	-5.400	92.00	21.74	14.52	0.3704E-01
30	-5.600	96.78	22.80	16.59	0.3704E-01
31	-5.800	101.5	23.80	18.67	0.3704E-01
32	-6.000	106.2	24.71	20.74	0.3704E-01
33	-6.200	110.8	25.55	22.81	0.3704E-01
34	-6.400	115.4	26.36	24.89	0.3704E-01
35	-6.600	119.9	27.14	26.96	0.3704E-01

PARATIE 7.00

Ce.A.S. s.r.l. - Milano

PAG. 29

15 NOVEMBRE 2011 18:06:08

History 0 - ORMENIS

SOIL EL.	QUOTA	SIGMA-H	TAGLIO	PR. ACQUA	GRAD. MAX
36	-6.800	124.5	27.88	29.04	0.3704E-01
37	-7.000	129.0	28.59	31.11	0.3704E-01
38	-7.200	133.5	29.28	33.19	0.3704E-01
39	-7.400	138.0	29.94	35.26	0.3704E-01
40	-7.600	142.5	30.58	37.33	0.3704E-01
41	-7.800	146.9	31.20	39.41	0.3704E-01
42	-8.000	151.3	31.80	41.48	0.3704E-01
43	-8.200	155.8	32.38	43.56	0.3704E-01
44	-8.400	160.2	32.95	45.63	0.3704E-01
45	-8.600	164.5	34.86	47.70	0.1313
46	-8.800	168.9	38.88	49.78	0.1313
47	-9.000	173.2	41.54	51.85	0.1313
48	-9.200	177.6	43.63	53.93	0.1313
49	-9.400	181.9	45.39	56.00	0.1313
50	-9.600	186.2	46.93	58.07	0.1313
51	-9.800	190.5	48.30	60.15	0.1313
52	-10.00	194.8	49.55	62.22	0.1313
53	-10.20	199.1	50.69	64.30	0.1313
54	-10.40	203.3	51.74	66.37	0.1313
55	-10.60	207.6	52.71	68.44	0.1313
56	-10.80	211.8	53.62	70.52	0.1313
57	-11.00	216.0	54.48	72.59	0.1313
58	-11.20	220.3	55.28	74.67	0.1313
59	-11.40	224.5	56.03	76.74	0.1313
60	-11.60	228.7	56.74	78.81	0.1313
61	-11.80	232.9	57.41	80.89	0.1313
62	-12.00	237.1	58.05	82.96	0.1313
63	-12.20	241.3	58.65	85.04	0.1313
64	-12.40	245.4	59.23	87.11	0.1313
65	-12.60	249.6	59.77	89.19	0.2308
66	-12.80	253.8	60.29	91.26	0.2308
67	-13.00	258.0	60.78	93.33	0.2308
68	-13.20	262.1	61.26	95.41	0.2308
69	-13.40	266.3	61.71	97.48	0.2308
70	-13.60	270.4	62.14	99.56	0.2308
71	-13.80	274.6	62.56	101.6	0.2308
72	-14.00	278.7	62.96	103.7	0.2308
73	-14.20	282.9	63.34	105.8	0.2308
74	-14.40	287.0	63.83	107.9	0.2308
75	-14.60	291.2	66.38	109.9	0.2308
76	-14.80	295.3	68.92	112.0	0.2308
77	-15.00	301.4	90.59	114.1	0.2308
78	-15.20	305.6	91.33	116.1	0.2308
79	-15.40	309.7	92.02	118.2	0.3115
80	-15.60	313.8	92.65	120.3	0.3115
81	-15.80	317.9	93.24	122.4	0.3115

PARATIE 7.00

Ce.A.S. s.r.l. - Milano

PAG. 30

15 NOVEMBRE 2011 18:06:08

History 0 - ORMENIS

SOIL EL.	QUOTA	SIGMA-H	TAGLIO	PR. ACQUA	GRAD. MAX
82	-16.00	322.0	93.79	124.4	0.3115
83	-16.20	326.1	94.31	126.5	0.3115
84	-16.40	330.2	94.79	128.6	0.3115
85	-16.60	334.3	95.24	130.7	0.3115
86	-16.80	338.5	96.02	132.7	0.3115
87	-17.00	342.6	97.31	134.8	0.3115
88	-17.20	346.7	98.49	136.9	0.3115
89	-17.40	350.8	99.58	139.0	0.3115
90	-17.60	354.9	100.6	141.0	0.3115
91	-17.80	359.1	101.5	143.1	0.3115
92	-18.00	363.2	102.4	145.2	0.3115
93	-18.20	367.3	103.3	147.3	0.3115
94	-18.40	371.4	104.1	149.3	0.3115
95	-18.60	375.6	104.8	151.4	0.3115
96	-18.80	379.7	105.6	153.5	0.3115
97	-19.00	383.9	106.2	155.6	0.3115
98	-19.20	388.0	106.9	157.6	0.3115
99	-19.40	392.1	107.5	159.7	0.3115
100	-19.60	396.3	108.2	161.8	0.3115
101	-19.80	400.4	108.7	163.9	0.3115
102	-20.00	404.6	109.3	165.9	0.3115
103	-20.20	408.7	109.9	168.0	0.3115
104	-20.40	412.9	110.4	170.1	0.3115
105	-20.60	417.1	110.9	172.1	0.3115
106	-20.80	421.2	111.4	174.2	0.3115
107	-21.00	425.4	111.9	176.3	0.3115
108	-21.20	429.5	112.4	178.4	0.3115
109	-21.40	433.7	112.9	180.4	0.3115
110	-21.60	437.9	113.3	182.5	0.3115
111	-21.80	442.0	113.8	184.6	0.3115
112	-22.00	446.2	114.2	186.7	0.3115
113	-22.20	450.4	114.7	188.7	0.3115
114	-22.40	454.6	115.1	190.8	0.3115
115	-22.60	458.7	115.5	192.9	0.3115
116	-22.80	462.9	115.9	195.0	0.3115
117	-23.00	467.1	116.3	197.0	0.3115
118	-23.20	471.3	116.7	199.1	0.3115
119	-23.40	475.5	117.1	201.2	0.3115
120	-23.60	479.6	117.5	203.3	0.3115
121	-23.80	483.8	117.9	205.3	0.3115
122	-24.00	488.0	118.3	207.4	0.3115
123	-24.20	492.2	118.7	209.5	0.3115
124	-24.40	496.4	119.0	211.6	0.3115
125	-24.60	500.6	119.4	213.6	0.3115
126	-24.80	504.7	119.8	215.7	0.3115
127	-25.00	508.9	120.1	217.8	0.3115

PARATIE 7.00

Ce.A.S. s.r.l. - Milano

PAG. 31

15 NOVEMBRE 2011 18:06:08

History 0 - ORMENIS

SOIL EL.	QUOTA	SIGMA-H	TAGLIO	PR. ACQUA	GRAD. MAX
128	-25.20	513.1	120.5	219.9	0.3115
129	-25.40	517.3	120.9	221.9	0.3115
130	-25.60	521.5	121.2	224.0	0.3115
131	-25.80	525.7	121.6	226.1	0.3115
132	-26.00	529.9	121.9	228.1	0.3115
133	-26.20	534.1	122.3	230.2	0.3115
134	-26.40	538.3	122.6	232.3	0.3115
135	-26.60	542.5	123.0	234.4	0.3115
136	-26.80	546.6	123.3	236.4	0.3115
137	-27.00	550.8	123.6	238.5	0.3115
138	-27.20	555.0	124.0	240.6	0.3115
139	-27.40	559.2	124.3	242.7	0.3115
140	-27.60	563.4	124.6	244.7	0.3115
141	-27.80	567.6	125.0	246.8	0.3115
142	-28.00	571.8	125.3	248.9	0.3115
143	-28.20	576.3	125.8	251.0	0.3115
144	-28.40	580.5	126.3	253.0	0.3115
145	-28.60	584.7	126.8	255.1	0.3115
146	-28.80	588.9	127.2	257.2	0.3115
147	-29.00	593.1	127.7	259.3	0.3115
148	-29.20	597.3	128.2	261.3	0.3115
149	-29.40	601.5	128.6	263.4	0.3115
150	-29.60	605.7	129.1	265.5	0.3115
151	-29.80	609.9	129.6	267.6	0.3115
152	-30.00	614.1	130.0	269.6	0.3115

INVILUPPO RISULTATI NEGLI ELEMENTI TERRENO

* PARETE RightWall GRUPPO UHRight*

STEP 1 - 9

* I PASSI NON EQUILIBRATI SONO ESCLUSI *

Nella tabella si stampano i seguenti risultati:

SIGMA-H = massimo sforzo orizzontale efficace [kPa]

TAGLIO = massimo sforzo di taglio [kPa]

PR. ACQUA =massima pressione interstiziale [kPa]

GRAD. MAX =massimo gradiente idraulico

SOIL EL.	QUOTA	SIGMA-H	TAGLIO	PR. ACQUA	GRAD. MAX
1	0.	12.79	5.103	0.	0.
2	-0.2000	25.56	4.406	0.	0.
3	-0.4000	37.19	8.812	0.	0.
4	-0.5000	42.47	11.02	0.	0.
5	-0.7000	43.79	10.81	0.	0.
6	-0.9000	44.48	10.29	0.	0.
7	-1.100	45.19	9.768	0.	0.
8	-1.300	45.90	9.255	0.	0.
9	-1.500	46.62	8.746	0.	0.
10	-1.700	48.79	8.243	0.	0.
11	-1.900	51.60	7.748	0.	0.
12	-2.100	54.42	7.428	0.9630	0.3115
13	-2.300	57.27	8.516	2.889	0.3115
14	-2.500	60.13	10.01	4.815	0.3115
15	-2.700	63.01	11.49	6.741	0.3115
16	-2.900	65.92	12.96	8.667	0.3115
17	-3.100	68.85	14.42	10.59	0.3115
18	-3.300	71.80	15.86	12.52	0.3115
19	-3.500	74.78	17.29	14.44	0.3115
20	-3.700	77.79	18.71	16.37	0.3115
21	-3.900	80.82	20.11	18.30	0.3115
22	-4.000	82.34	20.81	19.26	0.3115
23	-4.200	85.41	22.19	21.19	0.3115
24	-4.400	88.51	23.56	23.11	0.3115
25	-4.600	91.63	24.91	25.04	0.3115
26	-4.800	94.78	26.24	26.96	0.3115
27	-5.000	98.48	31.72	28.89	0.3115
28	-5.200	102.0	33.21	30.81	0.3115
29	-5.400	105.5	34.58	32.74	0.3115
30	-5.600	109.1	35.69	34.67	0.3115
31	-5.800	112.7	36.77	36.59	0.3115
32	-6.000	116.3	37.82	38.52	0.3115
33	-6.200	119.9	38.88	40.44	0.3115
34	-6.400	123.4	39.95	42.37	0.3115
35	-6.600	127.0	40.99	44.30	0.3115

PARATIE 7.00

Ce.A.S. s.r.l. - Milano

PAG. 33

15 NOVEMBRE 2011 18:06:08

History 0 - ORMENIS

SOIL EL.	QUOTA	SIGMA-H	TAGLIO	PR. ACQUA	GRAD. MAX
36	-6.800	130.6	41.99	46.22	0.3115
37	-7.000	134.3	42.97	48.15	0.3115
38	-7.200	138.0	43.91	50.07	0.3115
39	-7.400	141.7	44.83	52.00	0.3115
40	-7.600	145.4	45.71	53.93	0.3115
41	-7.800	149.2	46.56	55.85	0.3115
42	-8.000	153.0	47.39	57.78	0.3115
43	-8.200	156.9	48.18	59.70	0.3115
44	-8.400	160.7	48.95	61.63	0.3115
45	-8.600	164.6	49.68	63.56	0.3115
46	-8.800	168.6	50.38	65.48	0.3115
47	-9.000	172.5	51.05	67.41	0.3115
48	-9.200	176.5	51.68	69.33	0.3115
49	-9.400	180.5	52.28	71.26	0.3115
50	-9.600	184.5	52.85	73.19	0.3115
51	-9.800	188.5	53.38	75.11	0.3115
52	-10.00	192.6	53.87	77.04	0.3115
53	-10.20	196.7	54.33	78.96	0.3115
54	-10.40	200.8	54.75	80.89	0.3115
55	-10.60	204.9	55.13	82.81	0.3115
56	-10.80	209.0	55.48	84.74	0.3115
57	-11.00	213.2	55.80	86.67	0.3115
58	-11.20	217.3	56.07	88.59	0.3115
59	-11.40	221.5	56.32	90.52	0.3115
60	-11.60	225.7	56.52	92.44	0.3115
61	-11.80	229.9	56.70	94.37	0.3115
62	-12.00	234.1	56.84	96.30	0.3115
63	-12.20	238.3	56.95	98.22	0.3115
64	-12.40	242.5	57.02	100.1	0.3115
65	-12.60	246.8	57.07	102.1	0.3115
66	-12.80	251.0	57.08	104.0	0.3115
67	-13.00	255.3	57.05	105.9	0.3115
68	-13.20	259.5	57.00	107.9	0.3115
69	-13.40	263.8	56.91	109.8	0.3115
70	-13.60	268.1	56.79	111.7	0.3115
71	-13.80	272.4	56.64	113.6	0.3115
72	-14.00	276.7	56.46	115.6	0.3115
73	-14.20	280.9	56.26	117.5	0.3115
74	-14.40	285.2	56.02	119.4	0.3115
75	-14.60	289.5	55.75	121.3	0.3115
76	-14.80	293.8	55.46	123.3	0.3115
77	-15.00	295.4	83.45	125.2	0.3115
78	-15.20	299.7	83.10	127.1	0.3115
79	-15.40	304.1	82.73	129.0	0.3115
80	-15.60	308.4	82.32	131.0	0.3115
81	-15.80	312.8	81.89	132.9	0.3115

PARATIE 7.00

Ce.A.S. s.r.l. - Milano

PAG. 34

15 NOVEMBRE 2011 18:06:08

History 0 - ORMENIS

SOIL EL.	QUOTA	SIGMA-H	TAGLIO	PR. ACQUA	GRAD. MAX
82	-16.00	317.1	81.44	134.8	0.3115
83	-16.20	321.4	80.96	136.7	0.3115
84	-16.40	325.8	80.46	138.7	0.3115
85	-16.60	330.1	79.94	140.6	0.3115
86	-16.80	334.5	79.41	142.5	0.3115
87	-17.00	338.8	78.85	144.4	0.3115
88	-17.20	343.1	78.28	146.4	0.3115
89	-17.40	347.5	77.70	148.3	0.3115
90	-17.60	351.8	77.10	150.2	0.3115
91	-17.80	356.1	76.49	152.1	0.3115
92	-18.00	360.4	75.87	154.1	0.3115
93	-18.20	364.7	75.24	156.0	0.3115
94	-18.40	369.1	74.60	157.9	0.3115
95	-18.60	373.4	73.95	159.9	0.3115
96	-18.80	377.7	73.30	161.8	0.3115
97	-19.00	382.0	72.63	163.7	0.3115
98	-19.20	386.3	71.96	165.6	0.3115
99	-19.40	390.5	71.29	167.6	0.3115
100	-19.60	394.8	70.61	169.5	0.3115
101	-19.80	399.1	69.93	171.4	0.3115
102	-20.00	403.4	69.24	173.3	0.3115
103	-20.20	407.7	68.55	175.3	0.3115
104	-20.40	411.9	67.86	177.2	0.3115
105	-20.60	416.2	67.17	179.1	0.3115
106	-20.80	420.5	66.47	181.0	0.3115
107	-21.00	424.7	65.77	183.0	0.3115
108	-21.20	429.0	65.08	184.9	0.3115
109	-21.40	433.3	64.38	186.8	0.3115
110	-21.60	437.5	63.68	188.7	0.3115
111	-21.80	441.8	62.98	190.7	0.3115
112	-22.00	446.0	62.28	192.6	0.3115
113	-22.20	450.2	61.58	194.5	0.3115
114	-22.40	454.5	60.88	196.4	0.3115
115	-22.60	458.7	60.18	198.4	0.3115
116	-22.80	463.0	59.49	200.3	0.3115
117	-23.00	467.2	58.79	202.2	0.3115
118	-23.20	471.4	58.09	204.1	0.3115
119	-23.40	475.7	57.40	206.1	0.3115
120	-23.60	479.9	56.71	208.0	0.3115
121	-23.80	484.1	56.01	209.9	0.3115
122	-24.00	488.3	55.32	211.9	0.3115
123	-24.20	492.6	54.63	213.8	0.3115
124	-24.40	496.8	53.94	215.7	0.3115
125	-24.60	501.0	53.25	217.6	0.3115
126	-24.80	505.2	52.56	219.6	0.3115
127	-25.00	509.4	51.87	221.5	0.3115

PARATIE 7.00

Ce.A.S. s.r.l. - Milano

PAG. 35

15 NOVEMBRE 2011 18:06:08

History 0 - ORMENIS

SOIL EL.	QUOTA	SIGMA-H	TAGLIO	PR. ACQUA	GRAD. MAX
128	-25.20	513.7	51.19	223.4	0.3115
129	-25.40	517.9	50.50	225.3	0.3115
130	-25.60	522.1	49.82	227.3	0.3115
131	-25.80	526.3	49.13	229.2	0.3115
132	-26.00	530.5	48.45	231.1	0.3115
133	-26.20	534.7	47.76	233.0	0.3115
134	-26.40	539.0	47.08	235.0	0.3115
135	-26.60	543.2	46.40	236.9	0.3115
136	-26.80	547.4	45.71	238.8	0.3115
137	-27.00	551.6	45.03	240.7	0.3115
138	-27.20	555.8	44.35	242.7	0.3115
139	-27.40	560.0	43.67	244.6	0.3115
140	-27.60	564.2	42.99	246.5	0.3115
141	-27.80	568.5	42.30	248.4	0.3115
142	-28.00	572.7	41.62	250.4	0.3115
143	-28.20	576.3	41.33	252.3	0.3115
144	-28.40	580.5	40.85	254.2	0.3115
145	-28.60	584.7	40.38	256.1	0.3115
146	-28.80	588.9	39.91	258.1	0.3115
147	-29.00	593.1	39.45	260.0	0.3115
148	-29.20	597.3	39.49	261.9	0.3115
149	-29.40	601.5	39.91	263.9	0.3115
150	-29.60	605.7	40.34	265.8	0.3115
151	-29.80	609.9	40.76	267.7	0.3115
152	-30.00	614.1	41.18	269.6	0.3115

RIASSUNTO SPINTE NEGLI ELEMENTI TERRENO
(LE SPINTE SONO CALCOLATE INTEGRANDO GLI SFORZI NEI SINGOLI ELEMENTI MOLLA)

SPINTA EFFICACE VERA = Integrale delle pressioni orizzontali efficaci in tutti gli elementi nel gruppo: unita' di misura kN/m

SPINTA ACQUA = Integrale delle pressioni interstiziali in tutti gli elementi nel gruppo: unita' di misura kN/m

SPINTA TOTALE VERA = Somma della SPINTA EFFICACE e della SPINTA DELL'ACQUA: e' l' azione totale sulla parete: unita' di misura kN/m

SPINTA ATTIVA POSSIBILE = La minima spinta che puo' essere esercitata da questo gruppo di elementi terreno, in questa fase: unita' di misura kN/m

SPINTA PASSIVA POSSIBILE = La massima spinta che puo' essere esercitata da questo gruppo di elementi terreno, in questa fase: unita' di misura kN/m

RAPPORTO PASSIVA/VERA = e' il rapporto tra la massima spinta possibile e la spinta efficace vera: fornisce un'indicazione su quanta spinta passiva venga mobilitata;

SPINTA PASSIVA MOBILITATA = e' l'inverso del rapporto precedente, espresso in unita' percentuale: indica quanta parte della massima spinta possibile e' stata mobilitata;

RAPPORTO VERA/ATTIVA = e' il rapporto tra la spinta efficace vera e la minima spinta possibile: fornisce un'indicazione di quanto questa porzione di terreno sia prossima alla condizione di massimo rilascio.

FASE	1	GRUPPO -->	DHRi	UHRi
SPINTA EFFICACE VERA			8943.6	9082.2
SPINTA ACQUA			0.	0.
SPINTA TOTALE VERA			8943.6	9082.2
SPINTA ATTIVA (POSSIBILE)			1921.3	2012.7
SPINTA PASSIVA (POSSIBILE)			38013.	39097.
RAPPORTO PASSIVA/VERA			4.2504	4.3048
SPINTA PASSIVA MOBILITATA			24.%	23.%
RAPPORTO VERA/ATTIVA			4.6551	4.5124

PARATIE 7.00

Ce.A.S. s.r.l. - Milano

PAG. 37

15 NOVEMBRE 2011 18:06:08

History 0 - ORMENIS

FASE	2	GRUPPO -->	DHRi	UHRi
		SPINTA EFFICACE VERA	6182.6	6068.0
		SPINTA ACQUA	3505.2	3774.9
		SPINTA TOTALE VERA	9687.8	9842.9
		SPINTA ATTIVA (POSSIBILE)	289.51	814.88
		SPINTA PASSIVA (POSSIBILE)	17101.	24290.
		RAPPORTO PASSIVA/VERA	2.7660	4.0030
		SPINTA PASSIVA MOBILITATA	36.%	25.%
		RAPPORTO VERA/ATTIVA	21.356	7.4466

FASE	3	GRUPPO -->	DHRi	UHRi
		SPINTA EFFICACE VERA	6149.7	6163.3
		SPINTA ACQUA	3505.2	3774.9
		SPINTA TOTALE VERA	9654.9	9938.2
		SPINTA ATTIVA (POSSIBILE)	289.51	814.88
		SPINTA PASSIVA (POSSIBILE)	17101.	24290.
		RAPPORTO PASSIVA/VERA	2.7808	3.9411
		SPINTA PASSIVA MOBILITATA	36.%	25.%
		RAPPORTO VERA/ATTIVA	21.242	7.5635

FASE	4	GRUPPO -->	DHRi	UHRi
		SPINTA EFFICACE VERA	5538.5	5113.0
		SPINTA ACQUA	2614.8	3405.3
		SPINTA TOTALE VERA	8153.3	8518.2
		SPINTA ATTIVA (POSSIBILE)	71.669	931.82
		SPINTA PASSIVA (POSSIBILE)	11699.	25740.
		RAPPORTO PASSIVA/VERA	2.1123	5.0342
		SPINTA PASSIVA MOBILITATA	47.%	20.%
		RAPPORTO VERA/ATTIVA	77.278	5.4870

FASE	5	GRUPPO -->	DHRi	UHRi
		SPINTA EFFICACE VERA	5477.6	5292.9
		SPINTA ACQUA	2614.8	3405.3
		SPINTA TOTALE VERA	8092.4	8698.2
		SPINTA ATTIVA (POSSIBILE)	71.669	931.82
		SPINTA PASSIVA (POSSIBILE)	11699.	25740.
		RAPPORTO PASSIVA/VERA	2.1357	4.8631
		SPINTA PASSIVA MOBILITATA	47.%	21.%
		RAPPORTO VERA/ATTIVA	76.429	5.6801

PARATIE 7.00

Ce.A.S. s.r.l. - Milano

PAG. 38

15 NOVEMBRE 2011 18:06:08

History 0 - ORMENIS

FASE	6	GRUPPO -->	DHRi	UHRi
		SPINTA EFFICACE VERA	4719.6	4330.2
		SPINTA ACQUA	1884.7	3015.4
		SPINTA TOTALE VERA	6604.3	7345.6
		SPINTA ATTIVA (POSSIBILE)	1.8429	1055.5
		SPINTA PASSIVA (POSSIBILE)	7814.5	27269.
		RAPPORTO PASSIVA/VERA	1.6557	6.2974
		SPINTA PASSIVA MOBILITATA	60.%	16.%
		RAPPORTO VERA/ATTIVA	2560.9	4.1027

FASE	7	GRUPPO -->	DHRi	UHRi
		SPINTA EFFICACE VERA	4658.3	4502.2
		SPINTA ACQUA	1884.7	3015.4
		SPINTA TOTALE VERA	6543.0	7517.6
		SPINTA ATTIVA (POSSIBILE)	1.8429	1055.5
		SPINTA PASSIVA (POSSIBILE)	7814.5	27269.
		RAPPORTO PASSIVA/VERA	1.6775	6.0568
		SPINTA PASSIVA MOBILITATA	60.%	17.%
		RAPPORTO VERA/ATTIVA	2527.7	4.2656

FASE	8	GRUPPO -->	DHRi	UHRi
		SPINTA EFFICACE VERA	4128.8	3937.8
		SPINTA ACQUA	1417.0	2699.1
		SPINTA TOTALE VERA	5545.9	6636.9
		SPINTA ATTIVA (POSSIBILE)	0.	1155.9
		SPINTA PASSIVA (POSSIBILE)	5678.5	28510.
		RAPPORTO PASSIVA/VERA	1.3753	7.2401
		SPINTA PASSIVA MOBILITATA	73.%	14.%
		RAPPORTO VERA/ATTIVA	0.10000E+06	3.4067

FASE	9	GRUPPO -->	DHRi	UHRi
		SPINTA EFFICACE VERA	4176.8	4233.9
		SPINTA ACQUA	1417.0	2699.1
		SPINTA TOTALE VERA	5593.8	6933.0
		SPINTA ATTIVA (POSSIBILE)	0.	1379.4
		SPINTA PASSIVA (POSSIBILE)	5678.5	31152.
		RAPPORTO PASSIVA/VERA	1.3596	7.3578
		SPINTA PASSIVA MOBILITATA	74.%	14.%
		RAPPORTO VERA/ATTIVA	0.10000E+06	3.0695

OUTPUT PLOTS:

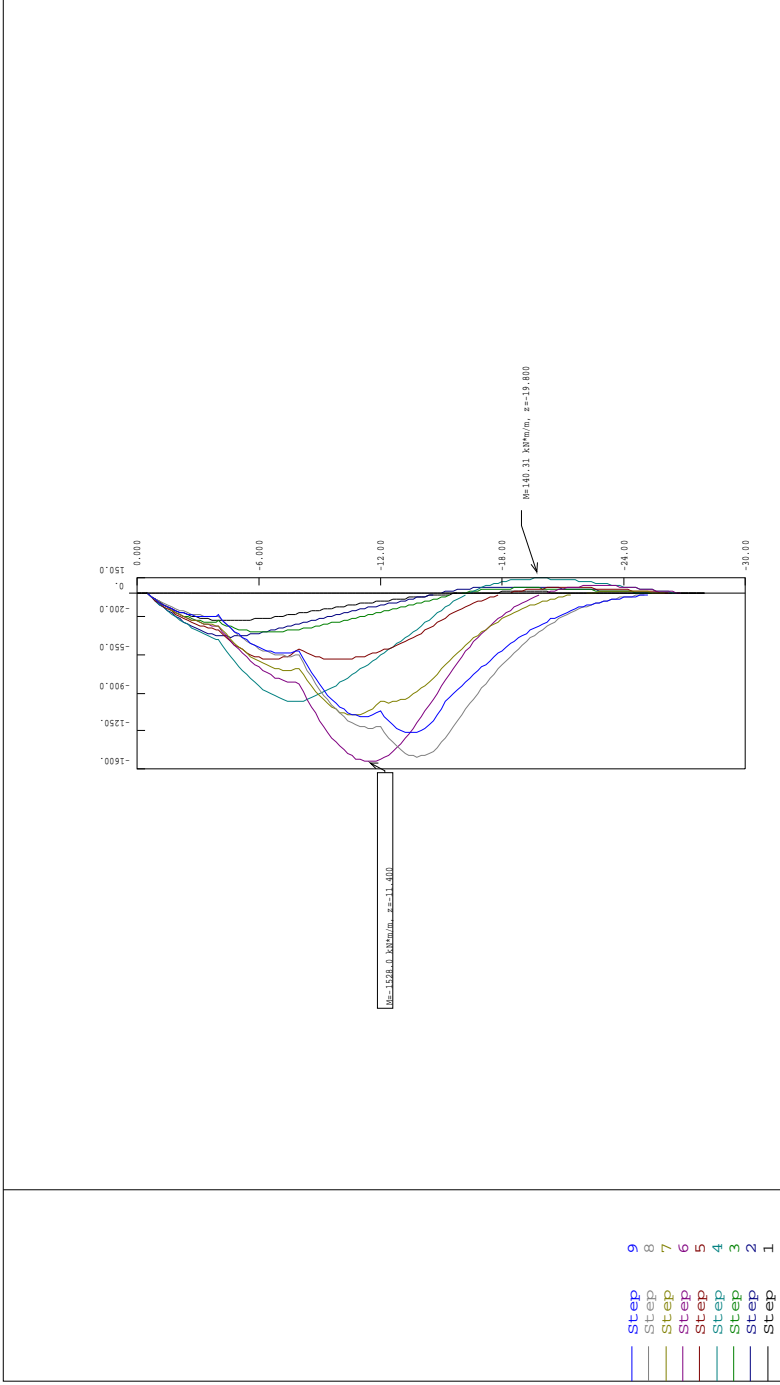

MOMENTI FLETTENTI [kN*m/m]
 INVILUPPO DA 1 A 9 SCALA GEOM. : 2.32

FILE: C:\Users\ADMINISTRATORE\Documents\cassa\cassa\cassa.dwg

History 0 - OPENED

Perce unitas KN
 Length unitas M

* Ce.A.S. S.r.l. Milano *
 www.ceas.it
 P A R A T I E 7.00
 15 NOVEMBRE 2011 18:06:08

Tirante_Wire2	
STEP	FORCE [KN/m]
1.	0.
2.	0.
3.	150.
4.	220.3
5.	192.1
6.	236.7
7.	221.4
8.	226.7
9.	259.3

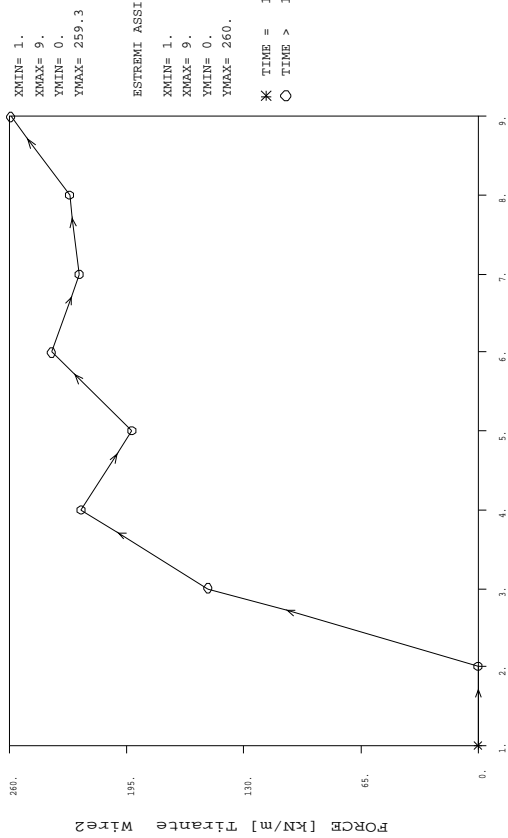

DAL PASSO 1 AL PASSO 9

DIAGRAMMA VARIABILE X / VARIABILE Y

History 0 - OPENSIS

URL: C:\Users\Trombini\Documents\cassa\1111\1111\Battelle_Dinamica_Gommi\cassa\cassa.dinamica\cassa.dinamica.dwg

Force units= KN
Length units= M

* Ce.A.S. S.r.l. Milano *

www.ceas.it

P A R A T I E 7.00

15 NOVEMBRE 2011 18:06:08

STEP	FORCE [kN/m]
1.	0.
2.	0.
3.	0.
4.	0.
5.	300.
6.	412.7
7.	379.8
8.	426.6
9.	444.5

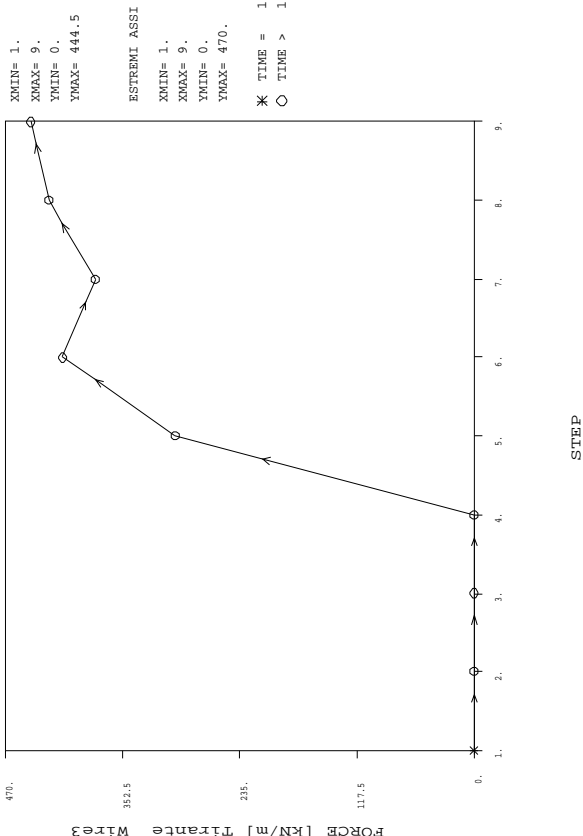

DAL PASSO 1 AL PASSO 9
 DIAGRAMMA VARIABILE X / VARIABILE Y

History 0 - OPENSIS

URL: C:\Users\Tommaso\Documents\Cattella - ILLUMI - Strada - Strada - C:\Users\Tommaso\Documents\Cattella - ILLUMI - Strada - Strada - CATTPELLI_ILUMI_STRADA

Force unitas: kN
 Length unitas: m

* Ce.A.S. S.r.l. Milano *
 www.ceas.it
 P A R A T I E 7.00
 15 NOVEMBRE 2011 18:06:08

Tirante W4e4	
STEP	FORCE [kN/m]
1.	0.
2.	0.
3.	0.
4.	0.
5.	0.
6.	0.
7.	300.
8.	392.2
9.	397.4

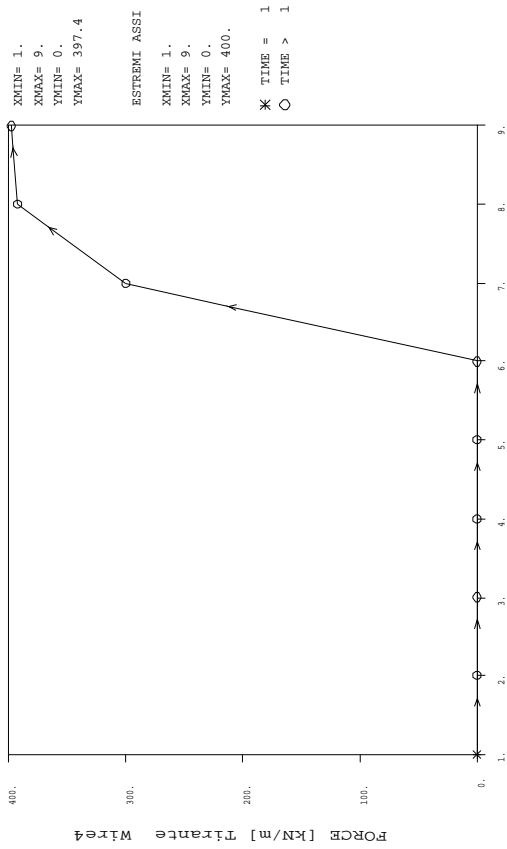

STEP

DAL PASSO 1 AL PASSO 9
 DIAGRAMMA VARIABILE X / VARIABILE Y

History 0 - OPERAS

Path: C:\Users\A\Documents\A\Work\op_bibione_concetto_11\11.dwg - 2D - 2D - 11.dwg - 11.dwg - 11.dwg - 11.dwg - 11.dwg - 11.dwg - 11.dwg - 11.dwg - 11.dwg

Force unitas: kN
 Length unitas: m

* Ce.A.S. S.r.l. Milano *
 www.ceas.it
 PARATE 7.00
 15 NOVEMBRE 2011 18:06:08

Table: Combination Definitions, Part 1 of 3

Table: Combination Definitions, Part 1 of 3						
ComboName	ComboType	AutoDesign	CaseType	CaseName	ScaleFactor	SteelDesign
USL1	Linear Add	No	Linear Static	EARTH	1,350000	None
USL1			Linear Static	EARTH_PRESSURE DX	1,350000	
USL1			Linear Static	EARTH_PRESSURE SX	1,350000	
USL1			Linear Static	HYDROSTATIC	1,350000	
USL1			Linear Static	DEAD	1,350000	
ULS2	Linear Add	No	Linear Static	DEAD	1,350000	None
ULS2			Linear Static	EARTH	1,350000	
ULS2			Linear Static	EARTH_PRESSURE DX	1,350000	
ULS2			Linear Static	EARTH_PRESSURE SX	1,350000	
ENVELOPE_ULS	Envelope	No	Response Combo	ULS2	1,000000	None
ENVELOPE_ULS			Response Combo	USL1	1,000000	
SLS	Linear Add	No	Linear Static	DEAD	1,000000	None
SLS			Linear Static	EARTH	1,000000	
SLS			Linear Static	EARTH_PRESSURE DX	1,000000	
SLS			Linear Static	EARTH_PRESSURE SX	1,000000	
SLS			Linear Static	HYDROSTATIC	1,000000	

Table: Combination Definitions, Part 2 of 3

Table: Combination Definitions, Part 2 of 3				
ComboName	CaseName	ConcDesign	AlumDesign	ColdDesign
USL1	EARTH	None	None	None
USL1	EARTH_PRESSURE DX			
USL1	EARTH_PRESSURE SX			
USL1	HYDROSTATIC			
USL1	DEAD			
ULS2	DEAD	None	None	None
ULS2	EARTH			
ULS2	EARTH_PRESSURE DX			
ULS2	EARTH_PRESSURE SX			
ENVELOPE_ULS	ULS2	None	None	None
ENVELOPE_ULS	USL1			
SLS	DEAD	None	None	None
SLS	EARTH			
SLS	EARTH_PRESSURE DX			
SLS	EARTH_PRESSURE SX			
SLS	HYDROSTATIC			

Table: Combination Definitions, Part 3 of 3

Table: Combination Definitions, Part 3 of 3

ComboName	CaseName	GUID	Notes
USL1	EARTH		
USL1	EARTH_PRESSURE DX		
USL1	EARTH_PRESSURE SX		
USL1	HYDROSTATIC		
USL1	DEAD		
ULS2	DEAD		
ULS2	EARTH		
ULS2	EARTH_PRESSURE DX		
ULS2	EARTH_PRESSURE SX		
ENVELOPE_ULS	ULS2		
ENVELOPE_ULS	USL1		
SLS	DEAD		
SLS	EARTH		
SLS	EARTH_PRESSURE DX		
SLS	EARTH_PRESSURE SX		
SLS	HYDROSTATIC		

Table: Element Forces - Frames, Part 1 of 2

Table: Element Forces - Frames, Part 1 of 2

Frame	Station m	OutputCase	CaseType	P KN	V2 KN	V3 KN	T KN-m	M2 KN-m
1	0,00000	USL1	Combination	-1425,077	281,459	3,857E-14	1,574E-13	-5,111E-14
1	0,23812	USL1	Combination	-1437,197	328,726	3,857E-14	1,574E-13	-6,030E-14
1	0,47625	USL1	Combination	-1449,317	377,368	3,857E-14	1,574E-13	-6,948E-14
1	0,00000	ULS2	Combination	-1289,675	213,215	1,975E-16	-8,262E-16	-3,153E-15
1	0,23812	ULS2	Combination	-1301,794	239,631	1,975E-16	-8,262E-16	-3,200E-15
1	0,47625	ULS2	Combination	-1313,914	266,739	1,975E-16	-8,262E-16	-3,247E-15
1	0,00000	SLS	Combination	-1055,613	208,488	2,857E-14	1,166E-13	-3,786E-14
1	0,23812	SLS	Combination	-1064,590	243,501	2,857E-14	1,166E-13	-4,467E-14
1	0,47625	SLS	Combination	-1073,568	279,532	2,857E-14	1,166E-13	-5,147E-14
2	0,00000	USL1	Combination	-1084,529	-728,067	7,694E-14	8,732E-14	-7,407E-14
2	0,57862	USL1	Combination	-1006,659	-562,579	7,694E-14	8,732E-14	-1,186E-13
2	1,15723	USL1	Combination	-926,772	-401,920	7,694E-14	8,732E-14	-1,631E-13
2	0,00000	ULS2	Combination	-921,067	-699,446	1,975E-16	9,905E-16	2,670E-15
2	0,57862	ULS2	Combination	-843,197	-562,392	1,975E-16	9,905E-16	2,556E-15
2	1,15723	ULS2	Combination	-763,310	-427,354	1,975E-16	9,905E-16	2,442E-15
2	0,00000	SLS	Combination	-803,355	-539,309	5,699E-14	6,468E-14	-5,487E-14
2	0,57862	SLS	Combination	-745,673	-416,726	5,699E-14	6,468E-14	-8,784E-14
2	1,15723	SLS	Combination	-686,498	-297,719	5,699E-14	6,468E-14	-1,208E-13
3	0,00000	USL1	Combination	-926,772	-401,920	7,694E-14	9,691E-14	-1,510E-13
3	0,51232	USL1	Combination	-864,988	-274,337	7,694E-14	9,691E-14	-1,905E-13
3	1,02464	USL1	Combination	-801,639	-150,567	7,694E-14	9,691E-14	-2,299E-13
3	0,00000	ULS2	Combination	-763,310	-427,354	1,975E-16	9,905E-16	2,442E-15
3	0,51232	ULS2	Combination	-701,526	-320,087	1,975E-16	9,905E-16	2,340E-15
3	1,02464	ULS2	Combination	-638,177	-214,386	1,975E-16	9,905E-16	2,239E-15
3	0,00000	SLS	Combination	-686,498	-297,719	5,699E-14	7,179E-14	-1,119E-13
3	0,51232	SLS	Combination	-640,732	-203,213	5,699E-14	7,179E-14	-1,411E-13
3	1,02464	SLS	Combination	-593,807	-111,531	5,699E-14	7,179E-14	-1,703E-13
4	0,00000	USL1	Combination	-793,623	-188,304	-3,817E-14	4,426E-14	-3,048E-13
4	0,49473	USL1	Combination	-748,842	-83,792	-3,817E-14	4,426E-14	-2,859E-13

Table: Element Forces - Frames, Part 1 of 2

Frame	Station m	OutputCase	CaseType	P KN	V2 KN	V3 KN	T KN-m	M2 KN-m
4	0,98945	USL1	Combination	-702,578	17,400	-3,817E-14	4,426E-14	-2,670E-13
4	0,00000	ULS2	Combination	-627,327	-244,322	1,975E-16	1,095E-15	2,190E-15
4	0,49473	ULS2	Combination	-582,545	-155,189	1,975E-16	1,095E-15	2,092E-15
4	0,98945	ULS2	Combination	-536,281	-67,404	1,975E-16	1,095E-15	1,994E-15
4	0,00000	SLS	Combination	-587,869	-139,484	-2,828E-14	3,279E-14	-2,258E-13
4	0,49473	SLS	Combination	-554,698	-62,068	-2,828E-14	3,279E-14	-2,118E-13
4	0,98945	SLS	Combination	-520,428	12,889	-2,828E-14	3,279E-14	-1,978E-13
5	0,00000	USL1	Combination	-692,126	-121,986	3,857E-14	-6,925E-15	-2,285E-13
5	0,49402	USL1	Combination	-671,877	-31,580	3,857E-14	-6,925E-15	-2,475E-13
5	0,98804	USL1	Combination	-650,311	56,505	3,857E-14	-6,925E-15	-2,666E-13
5	0,00000	ULS2	Combination	-512,335	-172,203	1,975E-16	1,468E-15	1,738E-15
5	0,49402	ULS2	Combination	-492,086	-93,434	1,975E-16	1,468E-15	1,641E-15
5	0,98804	ULS2	Combination	-470,520	-15,453	1,975E-16	1,468E-15	1,543E-15
5	0,00000	SLS	Combination	-512,686	-90,360	2,857E-14	-5,130E-15	-1,692E-13
5	0,49402	SLS	Combination	-497,686	-23,393	2,857E-14	-5,130E-15	-1,834E-13
5	0,98804	SLS	Combination	-481,712	41,855	2,857E-14	-5,130E-15	-1,975E-13
6	0,00000	USL1	Combination	-647,757	-80,667	1,975E-16	-5,340E-14	-1,906E-13
6	0,49382	USL1	Combination	-645,510	-2,472	1,975E-16	-5,340E-14	-1,907E-13
6	0,98763	USL1	Combination	-642,317	74,433	1,975E-16	-5,340E-14	-1,908E-13
6	0,00000	ULS2	Combination	-456,898	-113,457	1,975E-16	1,758E-15	1,202E-15
6	0,49382	ULS2	Combination	-454,651	-44,112	1,975E-16	1,758E-15	1,104E-15
6	0,98763	ULS2	Combination	-451,457	24,910	1,975E-16	1,758E-15	1,007E-15
6	0,00000	SLS	Combination	-479,820	-59,753	1,463E-16	-3,955E-14	-1,412E-13
6	0,49382	SLS	Combination	-478,156	-1,831	1,463E-16	-3,955E-14	-1,413E-13
6	0,98763	SLS	Combination	-475,790	55,136	1,463E-16	-3,955E-14	-1,414E-13
7	0,00000	USL1	Combination	-643,292	-65,467	-2,300E-13	-7,960E-14	-1,145E-13
7	0,52308	USL1	Combination	-655,962	5,594	-2,300E-13	-7,960E-14	5,816E-15
7	1,04617	USL1	Combination	-668,246	76,224	-2,300E-13	-7,960E-14	1,261E-13
7	0,00000	ULS2	Combination	-446,248	-72,778	1,975E-16	1,934E-15	6,051E-16
7	0,52308	ULS2	Combination	-458,918	-9,361	1,975E-16	1,934E-15	5,018E-16
7	1,04617	ULS2	Combination	-471,201	54,013	1,975E-16	1,934E-15	3,985E-16
7	0,00000	SLS	Combination	-476,513	-48,494	-1,704E-13	-5,896E-14	-8,482E-14
7	0,52308	SLS	Combination	-485,898	4,144	-1,704E-13	-5,896E-14	4,308E-15
7	1,04617	SLS	Combination	-494,997	56,462	-1,704E-13	-5,896E-14	9,343E-14
8	0,00000	USL1	Combination	-668,255	-76,141	1,975E-16	-9,395E-14	3,832E-14
8	0,54165	USL1	Combination	-655,797	-2,955	1,975E-16	-9,395E-14	3,822E-14
8	1,08329	USL1	Combination	-642,938	70,680	1,975E-16	-9,395E-14	3,811E-14
8	0,00000	ULS2	Combination	-471,268	-53,431	1,975E-16	1,974E-15	-4,703E-17
8	0,54165	ULS2	Combination	-458,809	12,241	1,975E-16	1,974E-15	-1,540E-16
8	1,08329	ULS2	Combination	-445,951	77,961	1,975E-16	1,974E-15	-2,610E-16
8	0,00000	SLS	Combination	-495,004	-56,401	1,463E-16	-6,959E-14	2,839E-14
8	0,54165	SLS	Combination	-485,775	-2,189	1,463E-16	-6,959E-14	2,831E-14
8	1,08329	SLS	Combination	-476,251	52,355	1,463E-16	-6,959E-14	2,823E-14
9	0,00000	USL1	Combination	-642,832	-71,644	-7,654E-14	-7,007E-14	3,768E-14
9	0,49252	USL1	Combination	-646,545	5,034	-7,654E-14	-7,007E-14	7,538E-14
9	0,98504	USL1	Combination	-649,317	83,004	-7,654E-14	-7,007E-14	1,131E-13
9	0,00000	ULS2	Combination	-452,205	-21,457	1,975E-16	1,869E-15	-6,864E-16
9	0,49252	ULS2	Combination	-455,919	47,357	1,975E-16	1,869E-15	-7,837E-16
9	0,98504	ULS2	Combination	-458,690	116,501	1,975E-16	1,869E-15	-8,810E-16
9	0,00000	SLS	Combination	-476,172	-53,069	-5,670E-14	-5,191E-14	2,791E-14
9	0,49252	SLS	Combination	-478,922	3,729	-5,670E-14	-5,191E-14	5,584E-14
9	0,98504	SLS	Combination	-480,976	61,484	-5,670E-14	-5,191E-14	8,376E-14
10	0,00000	USL1	Combination	-652,363	-54,079	1,975E-16	-7,989E-14	3,712E-14
10	0,49197	USL1	Combination	-674,379	33,490	1,975E-16	-7,989E-14	3,702E-14
10	0,98394	USL1	Combination	-695,090	123,379	1,975E-16	-7,989E-14	3,692E-14
10	0,00000	ULS2	Combination	-472,897	18,394	1,975E-16	1,645E-15	-1,251E-15
10	0,49197	ULS2	Combination	-494,913	95,900	1,975E-16	1,645E-15	-1,348E-15
10	0,98394	ULS2	Combination	-515,623	174,200	1,975E-16	1,645E-15	-1,445E-15
10	0,00000	SLS	Combination	-483,232	-40,058	1,463E-16	-5,918E-14	2,750E-14

Table: Element Forces - Frames, Part 1 of 2

Frame	Station m	OutputCase	CaseType	P KN	V2 KN	V3 KN	T KN-m	M2 KN-m
18	0,00000	ULS2	Combination	-196,906	-443,453	-3,461E-15	7,546E-15	-7,932E-15
18	0,47625	ULS2	Combination	-209,026	-384,400	-3,461E-15	7,546E-15	-6,283E-15
18	0,95249	ULS2	Combination	-221,145	-322,582	-3,461E-15	7,546E-15	-4,635E-15
18	0,00000	SLS	Combination	-198,088	-277,683	4,007E-14	4,822E-14	1,230E-15
18	0,47625	SLS	Combination	-207,066	-198,495	4,007E-14	4,822E-14	-1,785E-14
18	0,95249	SLS	Combination	-216,043	-115,235	4,007E-14	4,822E-14	-3,694E-14
19	0,00000	USL1	Combination	155,568	-83,647	-1,368E-14	-4,540E-14	-9,055E-14
19	0,38282	USL1	Combination	155,568	-51,631	-1,487E-14	-4,540E-14	-8,508E-14
19	0,76564	USL1	Combination	155,568	-19,615	-1,607E-14	-4,540E-14	-7,916E-14
19	0,00000	ULS2	Combination	322,582	73,198	5,503E-15	-4,635E-15	-1,381E-14
19	0,38282	ULS2	Combination	322,582	63,456	4,310E-15	-4,635E-15	-1,569E-14
19	0,76564	ULS2	Combination	322,582	53,714	3,117E-15	-4,635E-15	-1,711E-14
19	0,00000	SLS	Combination	115,235	-61,961	-1,013E-14	-3,363E-14	-6,707E-14
19	0,38282	SLS	Combination	115,235	-38,245	-1,102E-14	-3,363E-14	-6,302E-14
19	0,76564	SLS	Combination	115,235	-14,530	-1,190E-14	-3,363E-14	-5,864E-14
20	0,00000	USL1	Combination	155,568	-19,615	7,986E-14	-5,499E-14	-1,034E-13
20	0,36365	USL1	Combination	155,568	10,798	7,872E-14	-5,499E-14	-1,323E-13
20	0,72730	USL1	Combination	155,568	41,210	7,759E-14	-5,499E-14	-1,607E-13
20	0,00000	ULS2	Combination	322,582	53,714	3,117E-15	-4,635E-15	-1,711E-14
20	0,36365	ULS2	Combination	322,582	44,459	1,983E-15	-4,635E-15	-1,804E-14
20	0,72730	ULS2	Combination	322,582	35,205	8,502E-16	-4,635E-15	-1,855E-14
20	0,00000	SLS	Combination	115,235	-14,530	5,915E-14	-4,074E-14	-7,662E-14
20	0,36365	SLS	Combination	115,235	7,998	5,831E-14	-4,074E-14	-9,798E-14
20	0,72730	SLS	Combination	115,235	30,526	5,747E-14	-4,074E-14	-1,190E-13
21	0,00000	USL1	Combination	-1182,896	-304,885	-4,402E-14	5,453E-14	-2,834E-13
21	0,50061	USL1	Combination	-1244,405	-217,406	-4,011E-14	5,453E-14	-2,623E-13
21	1,00122	USL1	Combination	-1307,425	-126,667	-3,605E-14	5,453E-14	-2,432E-13
21	0,00000	ULS2	Combination	-895,961	-361,058	-4,402E-14	-3,022E-15	-1,477E-14
21	0,50061	ULS2	Combination	-957,470	-329,166	-4,011E-14	-3,022E-15	6,299E-15
21	1,00122	ULS2	Combination	-1020,490	-295,974	-3,605E-14	-3,022E-15	2,537E-14
21	0,00000	SLS	Combination	-876,219	-225,841	-3,261E-14	4,039E-14	-2,099E-13
21	0,50061	SLS	Combination	-921,781	-161,042	-2,971E-14	4,039E-14	-1,943E-13
21	1,00122	SLS	Combination	-968,463	-93,828	-2,670E-14	4,039E-14	-1,802E-13
22	0,00000	USL1	Combination	-1162,509	-186,080	-2,774E-14	2,063E-14	-2,618E-13
22	0,49901	USL1	Combination	-1231,760	-104,760	-2,502E-14	2,063E-14	-2,487E-13
22	0,99802	USL1	Combination	-1302,347	-21,108	-2,220E-14	2,063E-14	-2,369E-13
22	0,00000	ULS2	Combination	-806,978	-228,093	-2,774E-14	-3,349E-15	2,594E-14
22	0,49901	ULS2	Combination	-876,229	-205,888	-2,502E-14	-3,349E-15	3,911E-14
22	0,99802	ULS2	Combination	-946,817	-182,899	-2,220E-14	-3,349E-15	5,090E-14
22	0,00000	SLS	Combination	-861,117	-137,837	-2,055E-14	1,528E-14	-1,939E-13
22	0,49901	SLS	Combination	-912,415	-77,600	-1,853E-14	1,528E-14	-1,842E-13
22	0,99802	SLS	Combination	-964,702	-15,635	-1,645E-14	1,528E-14	-1,755E-13
23	0,00000	USL1	Combination	-1207,363	-102,812	-8,975E-14	-2,042E-14	-2,553E-13
23	0,49922	USL1	Combination	-1282,393	-32,587	-8,874E-14	-2,042E-14	-2,108E-13
23	0,99844	USL1	Combination	-1358,318	38,881	-8,769E-14	-2,042E-14	-1,667E-13
23	0,00000	ULS2	Combination	-799,475	-107,888	-1,301E-14	-3,632E-15	5,163E-14
23	0,49922	ULS2	Combination	-874,505	-99,598	-1,200E-14	-3,632E-15	5,787E-14
23	0,99844	ULS2	Combination	-950,429	-91,010	-1,095E-14	-3,632E-15	6,360E-14
23	0,00000	SLS	Combination	-894,343	-76,157	-6,648E-14	-1,512E-14	-1,891E-13
23	0,49922	SLS	Combination	-949,921	-24,138	-6,573E-14	-1,512E-14	-1,561E-13
23	0,99844	SLS	Combination	-1006,161	28,801	-6,495E-14	-1,512E-14	-1,235E-13
24	0,00000	USL1	Combination	-1314,554	-54,785	-1,548E-13	-7,334E-14	-1,658E-13
24	0,52170	USL1	Combination	-1394,998	3,696	-1,558E-13	-7,334E-14	-8,479E-14
24	1,04339	USL1	Combination	-1476,458	62,639	-1,568E-13	-7,334E-14	-3,265E-15
24	0,00000	ULS2	Combination	-879,368	-12,667	-1,354E-15	-3,800E-15	6,439E-14
24	0,52170	ULS2	Combination	-959,812	-20,566	-2,321E-15	-3,800E-15	6,535E-14
24	1,04339	ULS2	Combination	-1041,272	-28,354	-3,275E-15	-3,800E-15	6,681E-14
24	0,00000	SLS	Combination	-973,744	-40,581	-1,147E-13	-5,433E-14	-1,228E-13
24	0,52170	SLS	Combination	-1033,332	2,737	-1,154E-13	-5,433E-14	-6,281E-14

Table: Element Forces - Frames, Part 1 of 2

Frame	Station m	OutputCase	CaseType	P KN	V2 KN	V3 KN	T KN-m	M2 KN-m
24	1,04339	SLS	Combination	-1093,673	46,399	-1,161E-13	-5,433E-14	-2,418E-15
25	0,00000	USL1	Combination	-1476,558	-58,144	-1,499E-13	-9,017E-14	-4,747E-14
25	0,50307	USL1	Combination	-1398,036	-1,611	-1,508E-13	-9,017E-14	2,816E-14
25	1,00615	USL1	Combination	-1320,493	54,480	-1,518E-13	-9,017E-14	1,043E-13
25	0,00000	ULS2	Combination	-1040,680	27,928	3,618E-15	-3,841E-15	6,763E-14
25	0,50307	ULS2	Combination	-962,158	20,111	2,660E-15	-3,841E-15	6,605E-14
25	1,00615	ULS2	Combination	-884,616	12,192	1,691E-15	-3,841E-15	6,496E-14
25	0,00000	SLS	Combination	-1093,746	-43,069	-1,110E-13	-6,679E-14	-3,517E-14
25	0,50307	SLS	Combination	-1035,582	-1,193	-1,117E-13	-6,679E-14	2,086E-14
25	1,00615	SLS	Combination	-978,143	40,355	-1,124E-13	-6,679E-14	7,724E-14
26	0,00000	USL1	Combination	-255,300	-476,279	5,889E-14	6,630E-14	3,838E-14
26	0,23812	USL1	Combination	-261,360	-426,262	5,889E-14	6,630E-14	2,436E-14
26	0,47625	USL1	Combination	-267,419	-374,872	5,889E-14	6,630E-14	1,034E-14
26	0,00000	ULS2	Combination	-184,786	-499,742	-3,461E-15	7,546E-15	-9,580E-15
26	0,23812	ULS2	Combination	-190,846	-471,943	-3,461E-15	7,546E-15	-8,756E-15
26	0,47625	ULS2	Combination	-196,906	-443,453	-3,461E-15	7,546E-15	-7,932E-15
26	0,00000	SLS	Combination	-189,111	-352,799	4,362E-14	4,911E-14	2,843E-14
26	0,23812	SLS	Combination	-193,600	-315,750	4,362E-14	4,911E-14	1,804E-14
26	0,47625	SLS	Combination	-198,088	-277,683	4,362E-14	4,911E-14	7,656E-15
27	0,00000	USL1	Combination	-1363,572	-34,921	1,651E-13	-6,131E-14	1,809E-13
27	0,50047	USL1	Combination	-1287,394	36,151	1,661E-13	-6,131E-14	9,797E-14
27	1,00094	USL1	Combination	-1212,116	105,985	1,671E-13	-6,131E-14	1,458E-14
27	0,00000	ULS2	Combination	-954,236	93,694	1,167E-14	-3,752E-15	6,576E-14
27	0,50047	ULS2	Combination	-878,058	101,729	1,266E-14	-3,752E-15	5,967E-14
27	1,00094	ULS2	Combination	-802,780	109,472	1,360E-14	-3,752E-15	5,310E-14
27	0,00000	SLS	Combination	-1010,053	-25,868	1,223E-13	-4,541E-14	1,340E-13
27	0,50047	SLS	Combination	-953,625	26,778	1,231E-13	-4,541E-14	7,257E-14
27	1,00094	SLS	Combination	-897,864	78,507	1,238E-13	-4,541E-14	1,080E-14
28	0,00000	USL1	Combination	-1306,700	23,633	-2,074E-13	-3,711E-14	1,306E-13
28	0,50102	USL1	Combination	-1235,671	107,137	-2,046E-13	-3,711E-14	2,338E-13
28	1,00204	USL1	Combination	-1165,990	188,306	-2,019E-13	-3,711E-14	3,356E-13
28	0,00000	ULS2	Combination	-949,129	184,980	2,285E-14	-3,540E-15	5,386E-14
28	0,50102	ULS2	Combination	-878,100	207,575	2,562E-14	-3,540E-15	4,171E-14
28	1,00204	ULS2	Combination	-808,419	229,393	2,829E-14	-3,540E-15	2,821E-14
28	0,00000	SLS	Combination	-967,926	17,506	-1,536E-13	-2,749E-14	9,674E-14
28	0,50102	SLS	Combination	-915,312	79,360	-1,516E-13	-2,749E-14	1,732E-13
28	1,00204	SLS	Combination	-863,696	139,486	-1,496E-13	-2,749E-14	2,486E-13
29	0,00000	USL1	Combination	-1314,042	91,301	3,316E-14	-2,240E-14	2,783E-13
29	0,50160	USL1	Combination	-1251,660	183,631	3,741E-14	-2,240E-14	2,606E-13
29	1,00321	USL1	Combination	-1190,763	272,662	4,149E-14	-2,240E-14	2,408E-13
29	0,00000	ULS2	Combination	-1029,871	269,186	3,316E-14	-3,216E-15	2,892E-14
29	0,50160	ULS2	Combination	-967,489	303,856	3,741E-14	-3,216E-15	1,121E-14
29	1,00321	ULS2	Combination	-906,593	337,189	4,149E-14	-3,216E-15	-8,586E-15
29	0,00000	SLS	Combination	-973,364	67,630	2,457E-14	-1,659E-14	2,062E-13
29	0,50160	SLS	Combination	-927,156	136,023	2,771E-14	-1,659E-14	1,930E-13
29	1,00321	SLS	Combination	-882,047	201,972	3,073E-14	-1,659E-14	1,784E-13
30	0,00000	USL1	Combination	159,947	-37,171	7,141E-14	-4,842E-14	6,199E-14
30	0,38282	USL1	Combination	159,947	-5,155	7,022E-14	-4,842E-14	3,488E-14
30	0,76564	USL1	Combination	159,947	26,861	6,902E-14	-4,842E-14	8,227E-15
30	0,00000	ULS2	Combination	328,450	-28,765	-5,330E-15	-4,607E-16	-1,475E-14
30	0,38282	ULS2	Combination	328,450	-38,507	-6,523E-15	-4,607E-16	-1,248E-14
30	0,76564	ULS2	Combination	328,450	-48,249	-7,716E-15	-4,607E-16	-9,757E-15
30	0,00000	SLS	Combination	118,479	-27,534	5,290E-14	-3,587E-14	4,592E-14
30	0,38282	SLS	Combination	118,479	-3,819	5,201E-14	-3,587E-14	2,584E-14
30	0,76564	SLS	Combination	118,479	19,897	5,113E-14	-3,587E-14	6,094E-15
31	0,00000	USL1	Combination	159,947	26,861	-8,445E-14	-4,363E-14	4,780E-14
31	0,38282	USL1	Combination	159,947	58,876	-8,565E-14	-4,363E-14	8,036E-14
31	0,76564	USL1	Combination	159,947	90,892	-8,684E-14	-4,363E-14	1,134E-13
31	0,00000	ULS2	Combination	328,450	-48,249	-7,716E-15	-4,607E-16	-9,757E-15

Table: Element Forces - Frames, Part 1 of 2

Frame	Station m	OutputCase	CaseType	P KN	V2 KN	V3 KN	T KN-m	M2 KN-m
31	0,38282	ULS2	Combination	328,450	-57,991	-8,909E-15	-4,607E-16	-6,575E-15
31	0,76564	ULS2	Combination	328,450	-67,733	-1,010E-14	-4,607E-16	-2,936E-15
31	0,00000	SLS	Combination	118,479	19,897	-6,256E-14	-3,232E-14	3,541E-14
31	0,38282	SLS	Combination	118,479	43,612	-6,344E-14	-3,232E-14	5,952E-14
31	0,76564	SLS	Combination	118,479	67,328	-6,433E-14	-3,232E-14	8,398E-14
32	0,00000	USL1	Combination	-300,637	159,947	7,679E-14	4,040E-14	7,103E-14
32	0,47625	USL1	Combination	-288,517	272,348	8,436E-14	4,040E-14	3,265E-14
32	0,95249	USL1	Combination	-276,398	379,251	9,159E-14	4,040E-14	-9,262E-15
32	0,00000	ULS2	Combination	-229,167	328,450	3,842E-14	3,230E-15	-5,706E-15
32	0,47625	ULS2	Combination	-217,048	390,268	4,599E-14	3,230E-15	-2,582E-14
32	0,95249	ULS2	Combination	-204,928	449,322	5,322E-14	3,230E-15	-4,945E-14
32	0,00000	SLS	Combination	-222,694	118,479	5,688E-14	2,993E-14	5,262E-14
32	0,47625	SLS	Combination	-213,717	201,739	6,249E-14	2,993E-14	2,418E-14
32	0,95249	SLS	Combination	-204,739	280,927	6,784E-14	2,993E-14	-6,860E-15
34	0,00000	USL1	Combination	-1427,134	-265,099	5,388E-14	1,259E-13	5,505E-14
34	0,47625	USL1	Combination	-1402,895	-174,687	6,009E-14	1,259E-13	2,790E-14
34	0,95249	USL1	Combination	-1378,656	-89,771	6,598E-14	1,259E-13	-2,138E-15
34	0,00000	ULS2	Combination	-1291,311	-188,304	-2,286E-14	-1,188E-15	-1,368E-13
34	0,47625	ULS2	Combination	-1267,072	-137,528	-1,664E-14	-1,188E-15	-1,274E-13
34	0,95249	ULS2	Combination	-1242,833	-89,485	-1,076E-14	-1,188E-15	-1,209E-13
34	0,00000	SLS	Combination	-1057,136	-196,370	3,991E-14	9,327E-14	4,078E-14
34	0,47625	SLS	Combination	-1039,182	-129,398	4,451E-14	9,327E-14	2,066E-14
34	0,95249	SLS	Combination	-1021,227	-66,497	4,887E-14	9,327E-14	-1,584E-15
35	0,00000	USL1	Combination	-1378,656	-68,777	6,001E-14	1,307E-13	2,779E-14
35	0,47625	USL1	Combination	-1354,417	10,641	6,556E-14	1,307E-13	-2,126E-15
35	0,95249	USL1	Combination	-1330,177	84,563	7,077E-14	1,307E-13	-3,460E-14
35	0,00000	ULS2	Combination	-1242,833	-59,869	-7,134E-15	-1,188E-15	-1,209E-13
35	0,47625	ULS2	Combination	-1218,594	-14,574	-1,587E-15	-1,188E-15	-1,188E-13
35	0,95249	ULS2	Combination	-1194,354	27,956	3,621E-15	-1,188E-15	-1,193E-13
35	0,00000	SLS	Combination	-1021,227	-50,946	4,445E-14	9,682E-14	2,058E-14
35	0,47625	SLS	Combination	-1003,272	7,883	4,856E-14	9,682E-14	-1,574E-15
35	0,95249	SLS	Combination	-985,317	62,639	5,242E-14	9,682E-14	-2,563E-14
36	0,00000	USL1	Combination	-1330,177	104,096	6,459E-14	1,235E-13	-4,259E-14
36	0,47625	USL1	Combination	-1305,938	172,520	6,946E-14	1,235E-13	-7,452E-14
36	0,95249	USL1	Combination	-1281,699	235,447	7,399E-14	1,235E-13	-1,087E-13
36	0,00000	ULS2	Combination	-1194,354	55,818	7,033E-15	-1,188E-15	-1,193E-13
36	0,47625	ULS2	Combination	-1170,115	95,583	1,190E-14	-1,188E-15	-1,238E-13
36	0,95249	ULS2	Combination	-1145,876	132,584	1,643E-14	-1,188E-15	-1,306E-13
36	0,00000	SLS	Combination	-985,317	77,108	4,784E-14	9,149E-14	-3,155E-14
36	0,47625	SLS	Combination	-967,362	127,792	5,145E-14	9,149E-14	-5,520E-14
36	0,95249	SLS	Combination	-949,407	174,405	5,481E-14	9,149E-14	-8,051E-14
37	0,00000	USL1	Combination	-276,398	379,251	-2,352E-14	4,160E-14	8,100E-15
37	0,23812	USL1	Combination	-270,338	430,642	-2,003E-14	4,160E-14	1,328E-14
37	0,47625	USL1	Combination	-264,278	480,658	-1,663E-14	4,160E-14	1,765E-14
37	0,00000	ULS2	Combination	-204,928	449,322	5,322E-14	3,230E-15	-4,945E-14
37	0,23812	ULS2	Combination	-198,868	477,812	5,671E-14	3,230E-15	-6,254E-14
37	0,47625	ULS2	Combination	-192,809	505,611	6,011E-14	3,230E-15	-7,645E-14
37	0,00000	SLS	Combination	-204,739	280,927	-1,742E-14	3,081E-14	6,000E-15
37	0,23812	SLS	Combination	-200,250	318,994	-1,484E-14	3,081E-14	9,840E-15
37	0,47625	SLS	Combination	-195,762	356,043	-1,232E-14	3,081E-14	1,307E-14
38	0,00000	USL1	Combination	-1451,373	-382,050	1,205E-13	1,187E-13	7,927E-14
38	0,23812	USL1	Combination	-1439,254	-333,409	1,238E-13	1,187E-13	5,019E-14
38	0,47625	USL1	Combination	-1427,134	-286,141	1,270E-13	1,187E-13	2,032E-14
38	0,00000	ULS2	Combination	-1315,550	-271,201	-3,302E-14	-1,188E-15	-1,509E-13
38	0,23812	ULS2	Combination	-1303,431	-244,094	-2,970E-14	-1,188E-15	-1,435E-13
38	0,47625	ULS2	Combination	-1291,311	-217,677	-2,646E-14	-1,188E-15	-1,368E-13
38	0,00000	SLS	Combination	-1075,091	-283,000	8,923E-14	8,794E-14	5,872E-14
38	0,23812	SLS	Combination	-1066,114	-246,969	9,169E-14	8,794E-14	3,717E-14
38	0,47625	SLS	Combination	-1057,136	-211,956	9,409E-14	8,794E-14	1,505E-14

Table: Element Forces - Frames, Part 1 of 2

Frame	Station m	OutputCase	CaseType	P KN	V2 KN	V3 KN	T KN-m	M2 KN-m
39	0,00000	USL1	Combination	-1476,978	318,388	5,200E-14	-1,276E-14	1,691E-13
39	1,04715	USL1	Combination	-1458,799	298,904	4,962E-14	-1,276E-14	1,159E-13
39	2,09431	USL1	Combination	-1440,620	279,420	4,723E-14	-1,276E-14	6,519E-14
39	0,00000	ULS2	Combination	-1370,272	329,934	4,241E-14	-3,163E-15	6,033E-15
39	1,04715	ULS2	Combination	-1352,093	310,450	4,002E-14	-3,163E-15	-3,713E-14
39	2,09431	ULS2	Combination	-1333,913	290,966	3,764E-14	-3,163E-15	-7,779E-14
39	0,00000	SLS	Combination	-1094,058	235,843	3,852E-14	-9,449E-15	1,253E-13
39	1,04715	SLS	Combination	-1080,592	221,410	3,675E-14	-9,449E-15	8,585E-14
39	2,09431	SLS	Combination	-1067,126	206,978	3,499E-14	-9,449E-15	4,829E-14
40	0,00000	USL1	Combination	-1478,639	310,421	6,010E-14	2,696E-14	1,779E-13
40	1,03322	USL1	Combination	-1460,459	291,425	5,777E-14	2,696E-14	1,170E-13
40	2,06644	USL1	Combination	-1442,280	272,428	5,545E-14	2,696E-14	5,851E-14
40	0,00000	ULS2	Combination	-1370,800	323,807	4,331E-14	-1,213E-15	4,390E-16
40	1,03322	ULS2	Combination	-1352,620	304,811	4,099E-14	-1,213E-15	-4,311E-14
40	2,06644	ULS2	Combination	-1334,441	285,814	3,866E-14	-1,213E-15	-8,426E-14
40	0,00000	SLS	Combination	-1095,288	229,941	4,452E-14	1,997E-14	1,318E-13
40	1,03322	SLS	Combination	-1081,822	215,870	4,280E-14	1,997E-14	8,667E-14
40	2,06644	SLS	Combination	-1068,356	201,799	4,107E-14	1,997E-14	4,334E-14

Table: Element Forces - Frames, Part 2 of 2

Table: Element Forces - Frames, Part 2 of 2

Frame	Station m	OutputCase	M3 KN-m	FrameElem	ElemStation m
1	0,00000	USL1	-926,5079	1-1	0,00000
1	0,23812	USL1	-999,1302	1-1	0,23812
1	0,47625	USL1	-1083,1716	1-1	0,47625
1	0,00000	ULS2	-1130,2557	1-1	0,00000
1	0,23812	ULS2	-1184,1586	1-1	0,23812
1	0,47625	ULS2	-1244,4342	1-1	0,47625
1	0,00000	SLS	-686,3021	1-1	0,00000
1	0,23812	SLS	-740,0964	1-1	0,23812
1	0,47625	SLS	-802,3494	1-1	0,47625
2	0,00000	USL1	-944,4609	2-1	0,00000
2	0,57862	USL1	-571,2991	2-1	0,57862
2	1,15723	USL1	-292,4943	2-1	1,15723
2	0,00000	ULS2	-1087,6493	2-1	0,00000
2	0,57862	ULS2	-722,6865	2-1	0,57862
2	1,15723	ULS2	-436,4423	2-1	1,15723
2	0,00000	SLS	-699,6006	2-1	0,00000
2	0,57862	SLS	-423,1845	2-1	0,57862
2	1,15723	SLS	-216,6625	2-1	1,15723
3	0,00000	USL1	-292,4943	3-1	0,00000
3	0,51232	USL1	-119,4269	3-1	0,51232
3	1,02464	USL1	-10,7461	3-1	1,02464
3	0,00000	ULS2	-436,4423	3-1	0,00000
3	0,51232	ULS2	-245,0445	3-1	0,51232
3	1,02464	ULS2	-108,2005	3-1	1,02464
3	0,00000	SLS	-216,6625	3-1	0,00000
3	0,51232	SLS	-88,4644	3-1	0,51232
3	1,02464	SLS	-7,9601	3-1	1,02464
4	0,00000	USL1	-10,7461	4-1	0,00000
4	0,49473	USL1	56,4237	4-1	0,49473
4	0,98945	USL1	72,7099	4-1	0,98945
4	0,00000	ULS2	-108,2005	4-1	0,00000
4	0,49473	ULS2	-9,4317	4-1	0,49473
4	0,98945	ULS2	45,5741	4-1	0,98945
4	0,00000	SLS	-7,9601	4-1	0,00000

Table: Element Forces - Frames, Part 2 of 2

Frame	Station m	OutputCase	M3 KN-m	FrameElem	ElemStation m
4	0,49473	SLS	41,7953	4-1	0,49473
4	0,98945	SLS	53,8592	4-1	0,98945
5	0,00000	USL1	72,7099	5-1	0,00000
5	0,49402	USL1	110,5467	5-1	0,49402
5	0,98804	USL1	104,2945	5-1	0,98804
5	0,00000	ULS2	45,5741	5-1	0,00000
5	0,49402	ULS2	111,1565	5-1	0,49402
5	0,98804	ULS2	138,0202	5-1	0,98804
5	0,00000	SLS	53,8592	5-1	0,00000
5	0,49402	SLS	81,8864	5-1	0,49402
5	0,98804	SLS	77,2552	5-1	0,98804
6	0,00000	USL1	104,2945	6-1	0,00000
6	0,49382	USL1	124,7692	6-1	0,49382
6	0,98763	USL1	106,9485	6-1	0,98763
6	0,00000	ULS2	138,0202	6-1	0,00000
6	0,49382	ULS2	176,9120	6-1	0,49382
6	0,98763	ULS2	181,6399	6-1	0,98763
6	0,00000	SLS	77,2552	6-1	0,00000
6	0,49382	SLS	92,4217	6-1	0,49382
6	0,98763	SLS	79,2211	6-1	0,98763
7	0,00000	USL1	106,9485	7-1	0,00000
7	0,52308	USL1	122,5888	7-1	0,52308
7	1,04617	USL1	101,1710	7-1	1,04617
7	0,00000	ULS2	181,6399	7-1	0,00000
7	0,52308	ULS2	203,1207	7-1	0,52308
7	1,04617	ULS2	191,4405	7-1	1,04617
7	0,00000	SLS	79,2211	7-1	0,00000
7	0,52308	SLS	90,8065	7-1	0,52308
7	1,04617	SLS	74,9415	7-1	1,04617
8	0,00000	USL1	101,1710	8-1	0,00000
8	0,54165	USL1	122,6122	8-1	0,54165
8	1,08329	USL1	104,2910	8-1	1,08329
8	0,00000	ULS2	191,4405	8-1	0,00000
8	0,54165	ULS2	202,5978	8-1	0,54165
8	1,08329	ULS2	178,1711	8-1	1,08329
8	0,00000	SLS	74,9415	8-1	0,00000
8	0,54165	SLS	90,8239	8-1	0,54165
8	1,08329	SLS	77,2526	8-1	1,08329
9	0,00000	USL1	104,2910	9-1	0,00000
9	0,49252	USL1	120,7475	9-1	0,49252
9	0,98504	USL1	99,1204	9-1	0,98504
9	0,00000	ULS2	178,1711	9-1	0,00000
9	0,49252	ULS2	171,8064	9-1	0,49252
9	0,98504	ULS2	131,4680	9-1	0,98504
9	0,00000	SLS	77,2526	9-1	0,00000
9	0,49252	SLS	89,4426	9-1	0,49252
9	0,98504	SLS	73,4225	9-1	0,98504
10	0,00000	USL1	99,1204	10-1	0,00000
10	0,49197	USL1	104,2800	10-1	0,49197
10	0,98394	USL1	65,7881	10-1	0,98394
10	0,00000	ULS2	131,4680	10-1	0,00000
10	0,49197	ULS2	103,3860	10-1	0,49197
10	0,98394	ULS2	36,9784	10-1	0,98394
10	0,00000	SLS	73,4225	10-1	0,00000
10	0,49197	SLS	77,2445	10-1	0,49197
10	0,98394	SLS	48,7319	10-1	0,98394
11	0,00000	USL1	65,7881	11-1	0,00000
11	0,49208	USL1	48,3685	11-1	0,49208
11	0,98416	USL1	-19,3013	11-1	0,98416

Table: Element Forces - Frames, Part 2 of 2

Frame	Station m	OutputCase	M3 KN-m	FrameElem	ElemStation m
11	0,00000	ULS2	36,9784	11-1	0,00000
11	0,49208	ULS2	-18,9919	11-1	0,49208
11	0,98416	ULS2	-118,1679	11-1	0,98416
11	0,00000	SLS	48,7319	11-1	0,00000
11	0,49208	SLS	35,8285	11-1	0,49208
11	0,98416	SLS	-14,2973	11-1	0,98416
12	0,00000	USL1	-19,3013	12-1	0,00000
12	0,50938	USL1	-129,4486	12-1	0,50938
12	1,01876	USL1	-303,2460	12-1	1,01876
12	0,00000	ULS2	-118,1679	12-1	0,00000
12	0,50938	ULS2	-256,1028	12-1	0,50938
12	1,01876	ULS2	-447,9675	12-1	1,01876
12	0,00000	SLS	-14,2973	12-1	0,00000
12	0,50938	SLS	-95,8879	12-1	0,50938
12	1,01876	SLS	-224,6267	12-1	1,01876
13	0,00000	USL1	-303,2460	13-1	0,00000
13	0,56894	USL1	-578,3405	13-1	0,56894
13	1,13787	USL1	-944,6612	13-1	1,13787
13	0,00000	ULS2	-447,9675	13-1	0,00000
13	0,56894	ULS2	-730,3540	13-1	0,56894
13	1,13787	ULS2	-1088,8473	13-1	1,13787
13	0,00000	SLS	-224,6267	13-1	0,00000
13	0,56894	SLS	-428,4003	13-1	0,56894
13	1,13787	SLS	-699,7490	13-1	1,13787
14	0,00000	USL1	-944,6612	14-1	0,00000
14	0,47625	USL1	-845,6404	14-1	0,47625
14	0,95249	USL1	-777,8974	14-1	0,95249
14	0,00000	ULS2	-1088,8473	14-1	0,00000
14	0,47625	ULS2	-1032,6445	14-1	0,47625
14	0,95249	ULS2	-994,7215	14-1	0,95249
14	0,00000	SLS	-699,7490	14-1	0,00000
14	0,47625	SLS	-626,4003	14-1	0,47625
14	0,95249	SLS	-576,2203	14-1	0,95249
15	0,00000	USL1	-777,8974	15-1	0,00000
15	0,47625	USL1	-752,7591	15-1	0,47625
15	0,95249	USL1	-764,1345	15-1	0,95249
15	0,00000	ULS2	-994,7215	15-1	0,00000
15	0,47625	ULS2	-988,9335	15-1	0,47625
15	0,95249	ULS2	-1004,0585	15-1	0,95249
15	0,00000	SLS	-576,2203	15-1	0,00000
15	0,47625	SLS	-557,5994	15-1	0,47625
15	0,95249	SLS	-566,0256	15-1	0,95249
16	0,00000	USL1	-764,1345	16-1	0,00000
16	0,47625	USL1	-824,4464	16-1	0,47625
16	0,95249	USL1	-926,5079	16-1	0,95249
16	0,00000	ULS2	-1004,0585	16-1	0,00000
16	0,47625	ULS2	-1055,3916	16-1	0,47625
16	0,95249	ULS2	-1130,2557	16-1	0,95249
16	0,00000	SLS	-566,0256	16-1	0,00000
16	0,47625	SLS	-610,7010	16-1	0,47625
16	0,95249	SLS	-686,3021	16-1	0,95249
18	0,00000	USL1	-346,4733	18-1	0,00000
18	0,47625	USL1	-193,1800	18-1	0,47625
18	0,95249	USL1	-92,1081	18-1	0,95249
18	0,00000	ULS2	-416,8491	18-1	0,00000
18	0,47625	ULS2	-219,6084	18-1	0,47625
18	0,95249	ULS2	-51,1499	18-1	0,95249
18	0,00000	SLS	-256,6469	18-1	0,00000
18	0,47625	SLS	-143,0963	18-1	0,47625

Table: Element Forces - Frames, Part 2 of 2

Frame	Station m	OutputCase	M3 KN-m	FrameElem	ElemStation m
18	0,95249	SLS	-68,2282	18-1	0,95249
19	0,00000	USL1	-92,1081	19-1	0,00000
19	0,38282	USL1	-66,2145	19-1	0,38282
19	0,76564	USL1	-52,5773	19-1	0,76564
19	0,00000	ULS2	-51,1499	19-1	0,00000
19	0,38282	ULS2	-77,3067	19-1	0,38282
19	0,76564	ULS2	-99,7341	19-1	0,76564
19	0,00000	SLS	-68,2282	19-1	0,00000
19	0,38282	SLS	-49,0478	19-1	0,38282
19	0,76564	SLS	-38,9462	19-1	0,76564
20	0,00000	USL1	-52,5773	20-1	0,00000
20	0,36365	USL1	-50,9741	20-1	0,36365
20	0,72730	USL1	-60,4304	20-1	0,72730
20	0,00000	ULS2	-99,7341	20-1	0,00000
20	0,36365	ULS2	-117,5843	20-1	0,36365
20	0,72730	ULS2	-132,0693	20-1	0,72730
20	0,00000	SLS	-38,9462	20-1	0,00000
20	0,36365	SLS	-37,7586	20-1	0,36365
20	0,72730	SLS	-44,7632	20-1	0,72730
21	0,00000	USL1	7,9788	21-1	0,00000
21	0,50061	USL1	138,8472	21-1	0,50061
21	1,00122	USL1	225,1068	21-1	1,00122
21	0,00000	ULS2	-105,0763	21-1	0,00000
21	0,50061	ULS2	67,7448	21-1	0,50061
21	1,00122	ULS2	224,2749	21-1	1,00122
21	0,00000	SLS	5,9103	21-1	0,00000
21	0,50061	SLS	102,8498	21-1	0,50061
21	1,00122	SLS	166,7457	21-1	1,00122
22	0,00000	USL1	225,1068	22-1	0,00000
22	0,49901	USL1	297,7698	22-1	0,49901
22	0,99802	USL1	329,2715	22-1	0,99802
22	0,00000	ULS2	224,2749	22-1	0,00000
22	0,49901	ULS2	332,5881	22-1	0,49901
22	0,99802	ULS2	429,6251	22-1	0,99802
22	0,00000	SLS	166,7457	22-1	0,00000
22	0,49901	SLS	220,5702	22-1	0,49901
22	0,99802	SLS	243,9048	22-1	0,99802
23	0,00000	USL1	329,2715	23-1	0,00000
23	0,49922	USL1	363,1199	23-1	0,49922
23	0,99844	USL1	361,6005	23-1	0,99844
23	0,00000	ULS2	429,6251	23-1	0,00000
23	0,49922	ULS2	481,4279	23-1	0,49922
23	0,99844	ULS2	529,0178	23-1	0,99844
23	0,00000	SLS	243,9048	23-1	0,00000
23	0,49922	SLS	268,9777	23-1	0,49922
23	0,99844	SLS	267,8522	23-1	0,99844
24	0,00000	USL1	361,6005	24-1	0,00000
24	0,52170	USL1	374,9472	24-1	0,52170
24	1,04339	USL1	357,6641	24-1	1,04339
24	0,00000	ULS2	529,0178	24-1	0,00000
24	0,52170	ULS2	537,6915	24-1	0,52170
24	1,04339	ULS2	550,4571	24-1	1,04339
24	0,00000	SLS	267,8522	24-1	0,00000
24	0,52170	SLS	277,7387	24-1	0,52170
24	1,04339	SLS	264,9363	24-1	1,04339
25	0,00000	USL1	357,6641	25-1	0,00000
25	0,50307	USL1	372,6758	25-1	0,50307
25	1,00615	USL1	359,3587	25-1	1,00615
25	0,00000	ULS2	550,4571	25-1	0,00000

Table: Element Forces - Frames, Part 2 of 2

Frame	Station m	OutputCase	M3 KN-m	FrameElem	ElemStation m
25	0,50307	ULS2	538,3692	25-1	0,50307
25	1,00615	ULS2	530,2395	25-1	1,00615
25	0,00000	SLS	264,9363	25-1	0,00000
25	0,50307	SLS	276,0562	25-1	0,50307
25	1,00615	SLS	266,1917	25-1	1,00615
26	0,00000	USL1	-549,3701	26-1	0,00000
26	0,23812	USL1	-441,8849	26-1	0,23812
26	0,47625	USL1	-346,4733	26-1	0,47625
26	0,00000	ULS2	-641,5554	26-1	0,00000
26	0,23812	ULS2	-525,8513	26-1	0,23812
26	0,47625	ULS2	-416,8491	26-1	0,47625
26	0,00000	SLS	-406,9408	26-1	0,00000
26	0,23812	SLS	-327,3221	26-1	0,23812
26	0,47625	SLS	-256,6469	26-1	0,47625
27	0,00000	USL1	359,3587	27-1	0,00000
27	0,50047	USL1	358,9994	27-1	0,50047
27	1,00094	USL1	323,3804	27-1	1,00094
27	0,00000	ULS2	530,2395	27-1	0,00000
27	0,50047	ULS2	481,3255	27-1	0,50047
27	1,00094	ULS2	428,4632	27-1	1,00094
27	0,00000	SLS	266,1917	27-1	0,00000
27	0,50047	SLS	265,9255	27-1	0,50047
27	1,00094	SLS	239,5411	27-1	1,00094
28	0,00000	USL1	323,3804	28-1	0,00000
28	0,50102	USL1	290,5237	28-1	0,50102
28	1,00204	USL1	216,4146	28-1	1,00204
28	0,00000	ULS2	428,4632	28-1	0,00000
28	0,50102	ULS2	330,0914	28-1	0,50102
28	1,00204	ULS2	220,5937	28-1	1,00204
28	0,00000	SLS	239,5411	28-1	0,00000
28	0,50102	SLS	215,2027	28-1	0,50102
28	1,00204	SLS	160,3071	28-1	1,00204
29	0,00000	USL1	216,4146	29-1	0,00000
29	0,50160	USL1	147,3231	29-1	0,50160
29	1,00321	USL1	32,7460	29-1	1,00321
29	0,00000	ULS2	220,5937	29-1	0,00000
29	0,50160	ULS2	76,8178	29-1	0,50160
29	1,00321	ULS2	-84,0134	29-1	1,00321
29	0,00000	SLS	160,3071	29-1	0,00000
29	0,50160	SLS	109,1282	29-1	0,50160
29	1,00321	SLS	24,2563	29-1	1,00321
30	0,00000	USL1	-51,3175	30-1	0,00000
30	0,38282	USL1	-43,2158	30-1	0,38282
30	0,76564	USL1	-47,3704	30-1	0,76564
30	0,00000	ULS2	-124,2338	30-1	0,00000
30	0,38282	ULS2	-111,3574	30-1	0,38282
30	0,76564	ULS2	-94,7515	30-1	0,76564
30	0,00000	SLS	-38,0130	30-1	0,00000
30	0,38282	SLS	-32,0117	30-1	0,38282
30	0,76564	SLS	-35,0892	30-1	0,76564
31	0,00000	USL1	-47,3704	31-1	0,00000
31	0,38282	USL1	-63,7813	31-1	0,38282
31	0,76564	USL1	-92,4486	31-1	0,76564
31	0,00000	ULS2	-94,7515	31-1	0,00000
31	0,38282	ULS2	-74,4162	31-1	0,38282
31	0,76564	ULS2	-50,3514	31-1	0,76564
31	0,00000	SLS	-35,0892	31-1	0,00000
31	0,38282	SLS	-47,2454	31-1	0,38282
31	0,76564	SLS	-68,4804	31-1	0,76564

Table: Element Forces - Frames, Part 2 of 2

Frame	Station m	OutputCase	M3 KN-m	FrameElem	ElemStation m
32	0,00000	USL1	-92,4486	32-1	0,00000
32	0,47625	USL1	-195,6061	32-1	0,47625
32	0,95249	USL1	-350,9851	32-1	0,95249
32	0,00000	ULS2	-50,3514	32-1	0,00000
32	0,47625	ULS2	-221,6047	32-1	0,47625
32	0,95249	ULS2	-421,6403	32-1	0,95249
32	0,00000	SLS	-68,4804	32-1	0,00000
32	0,47625	SLS	-144,8934	32-1	0,47625
32	0,95249	SLS	-259,9890	32-1	0,95249
34	0,00000	USL1	-939,0068	34-1	0,00000
34	0,47625	USL1	-834,5018	34-1	0,47625
34	0,95249	USL1	-771,7464	34-1	0,95249
34	0,00000	ULS2	-1142,7945	34-1	0,00000
34	0,47625	ULS2	-1065,3149	34-1	0,47625
34	0,95249	ULS2	-1011,3663	34-1	0,95249
34	0,00000	SLS	-695,5606	34-1	0,00000
34	0,47625	SLS	-618,1495	34-1	0,47625
34	0,95249	SLS	-571,6640	34-1	0,95249
35	0,00000	USL1	-771,7464	35-1	0,00000
35	0,47625	USL1	-758,1212	35-1	0,47625
35	0,95249	USL1	-781,0097	35-1	0,95249
35	0,00000	ULS2	-1011,3663	35-1	0,00000
35	0,47625	ULS2	-993,7495	35-1	0,47625
35	0,95249	ULS2	-997,0458	35-1	0,95249
35	0,00000	SLS	-571,6640	35-1	0,00000
35	0,47625	SLS	-561,5713	35-1	0,47625
35	0,95249	SLS	-578,5257	35-1	0,95249
36	0,00000	USL1	-781,0097	36-1	0,00000
36	0,47625	USL1	-847,0964	36-1	0,47625
36	0,95249	USL1	-944,4609	36-1	0,95249
36	0,00000	ULS2	-997,0458	36-1	0,00000
36	0,47625	ULS2	-1033,2076	36-1	0,47625
36	0,95249	ULS2	-1087,6493	36-1	0,95249
36	0,00000	SLS	-578,5257	36-1	0,00000
36	0,47625	SLS	-627,4788	36-1	0,47625
36	0,95249	SLS	-699,6006	36-1	0,95249
37	0,00000	USL1	-350,9851	37-1	0,00000
37	0,23812	USL1	-447,4395	37-1	0,23812
37	0,47625	USL1	-555,9675	37-1	0,47625
37	0,00000	ULS2	-421,6403	37-1	0,00000
37	0,23812	ULS2	-532,0400	37-1	0,23812
37	0,47625	ULS2	-649,1415	37-1	0,47625
37	0,00000	SLS	-259,9890	37-1	0,00000
37	0,23812	SLS	-331,4367	37-1	0,23812
37	0,47625	SLS	-411,8278	37-1	0,47625
38	0,00000	USL1	-1097,9004	38-1	0,00000
38	0,23812	USL1	-1012,7441	38-1	0,23812
38	0,47625	USL1	-939,0068	38-1	0,47625
38	0,00000	ULS2	-1259,0980	38-1	0,00000
38	0,23812	ULS2	-1197,7599	38-1	0,23812
38	0,47625	ULS2	-1142,7945	38-1	0,47625
38	0,00000	SLS	-813,2596	38-1	0,00000
38	0,23812	SLS	-750,1808	38-1	0,23812
38	0,47625	SLS	-695,5606	38-1	0,47625
39	0,00000	USL1	84,0635	39-1	0,00000
39	1,04715	USL1	-239,1361	39-1	1,04715
39	2,09431	USL1	-541,9329	39-1	2,09431
39	0,00000	ULS2	40,2204	39-1	0,00000
39	1,04715	ULS2	-295,0695	39-1	1,04715

Table: Element Forces - Frames, Part 2 of 2

Frame	Station m	OutputCase	M3 KN-m	FrameElem	ElemStation m
39	2,09431	ULS2	-609,9566	39-1	2,09431
39	0,00000	SLS	62,2693	39-1	0,00000
39	1,04715	SLS	-177,1379	39-1	1,04715
39	2,09431	SLS	-401,4318	39-1	2,09431
40	0,00000	USL1	68,4092	40-1	0,00000
40	1,03322	USL1	-242,5098	40-1	1,03322
40	2,06644	USL1	-533,8015	40-1	2,06644
40	0,00000	ULS2	26,9929	40-1	0,00000
40	1,03322	ULS2	-297,7566	40-1	1,03322
40	2,06644	ULS2	-602,8788	40-1	2,06644
40	0,00000	SLS	50,6735	40-1	0,00000
40	1,03322	SLS	-179,6369	40-1	1,03322
40	2,06644	SLS	-395,4085	40-1	2,06644

Table: Element Joint Forces - Frames, Part 1 of 2

Table: Element Joint Forces - Frames, Part 1 of 2

Frame	Joint	OutputCase	CaseType	F1	F2	F3	M1	M2
				KN	KN	KN	KN-m	KN-m
1	28	USL1	Combination	-281,459	3,857E-14	-1425,077	-4,152E-14	-926,5079
1	35	USL1	Combination	377,368	-3,857E-14	1449,317	7,999E-14	1083,1716
1	28	ULS2	Combination	-213,215	1,975E-16	-1289,675	-3,153E-15	-1130,2557
1	35	ULS2	Combination	266,739	-1,975E-16	1313,914	3,247E-15	1244,4342
1	28	SLS	Combination	-208,488	2,857E-14	-1055,613	-3,076E-14	-686,3021
1	35	SLS	Combination	279,532	-2,857E-14	1073,568	5,925E-14	802,3494
2	11	USL1	Combination	252,057	7,454E-14	1281,699	-6,186E-15	-944,4609
2	12	USL1	Combination	-371,126	-7,454E-14	-939,527	-5,393E-14	292,4943
2	11	ULS2	Combination	156,710	1,975E-16	1145,876	-2,589E-15	-1087,6493
2	12	ULS2	Combination	-237,557	-1,975E-16	-841,926	2,427E-15	436,4423
2	11	SLS	Combination	186,709	5,521E-14	949,407	-4,582E-15	-699,6006
2	12	SLS	Combination	-274,908	-5,521E-14	-695,946	-3,995E-14	216,6625
3	12	USL1	Combination	371,126	1,249E-13	939,527	5,033E-14	-292,4943
3	13	USL1	Combination	-460,378	-1,249E-13	-673,312	-1,104E-13	10,7461
3	12	ULS2	Combination	237,557	1,975E-16	841,926	-2,427E-15	-436,4423
3	13	ULS2	Combination	-299,666	-1,975E-16	-602,854	2,284E-15	108,2005
3	12	SLS	Combination	274,908	9,252E-14	695,946	3,728E-14	-216,6625
3	13	SLS	Combination	-341,020	-9,252E-14	-498,749	-8,180E-14	7,9601
4	13	USL1	Combination	460,378	-3,098E-14	673,312	1,488E-13	-10,7461
4	14	USL1	Combination	-531,441	3,098E-14	-459,880	-1,291E-13	-72,7099
4	13	ULS2	Combination	299,666	1,975E-16	602,854	-2,284E-15	-108,2005
4	14	ULS2	Combination	-351,360	-1,975E-16	-410,716	2,152E-15	-45,5741
4	13	SLS	Combination	341,020	-2,295E-14	498,749	1,102E-13	-7,9601
4	14	SLS	Combination	-393,660	2,295E-14	-340,652	-9,566E-14	-53,8592
5	14	USL1	Combination	531,441	3,497E-14	459,880	1,188E-13	72,7099
5	15	USL1	Combination	-587,149	-3,497E-14	-285,225	-1,592E-13	-104,2945
5	14	ULS2	Combination	351,360	1,975E-16	410,716	-2,152E-15	45,5741
5	15	ULS2	Combination	-395,910	-1,975E-16	-254,722	2,052E-15	-138,0202
5	14	SLS	Combination	393,660	2,590E-14	340,652	8,800E-14	53,8592
5	15	SLS	Combination	-434,925	-2,590E-14	-211,278	-1,179E-13	-77,2552
6	15	USL1	Combination	587,149	-1,899E-14	285,225	1,062E-13	104,2945
6	16	USL1	Combination	-632,010	1,899E-14	-136,655	-8,074E-14	-106,9485
6	15	ULS2	Combination	395,910	1,975E-16	254,722	-2,052E-15	138,0202
6	16	ULS2	Combination	-435,376	-1,975E-16	-121,991	1,989E-15	-181,6399
6	15	SLS	Combination	434,925	-1,406E-14	211,278	7,869E-14	77,2552
6	16	SLS	Combination	-468,155	1,406E-14	-101,226	-5,981E-14	-79,2211
7	16	USL1	Combination	632,010	-2,060E-13	136,655	9,090E-14	106,9485
7	17	USL1	Combination	-672,578	2,060E-13	1,379	-7,522E-14	-101,1710
7	16	ULS2	Combination	435,376	1,975E-16	121,991	-1,989E-15	181,6399

Table: Element Joint Forces - Frames, Part 1 of 2

Frame	Joint	OutputCase	CaseType	F1 KN	F2 KN	F3 KN	M1 KN-m	M2 KN-m
7	17	ULS2	Combination	-474,285	-1,975E-16	1,235	1,966E-15	-191,4405
7	16	SLS	Combination	468,155	-1,526E-13	101,226	6,733E-14	79,2211
7	17	SLS	Combination	-498,206	1,526E-13	1,021	-5,572E-14	-74,9415
8	17	USL1	Combination	672,578	-2,738E-14	-1,379	9,216E-14	101,1710
8	18	USL1	Combination	-630,509	2,738E-14	144,303	-9,588E-14	-104,2910
8	17	ULS2	Combination	474,285	1,975E-16	-1,235	-1,966E-15	191,4405
8	18	ULS2	Combination	-433,995	-1,975E-16	128,834	1,991E-15	-178,1711
8	17	SLS	Combination	498,206	-2,028E-14	-1,021	6,827E-14	74,9415
8	18	SLS	Combination	-467,044	2,028E-14	106,891	-7,102E-14	-77,2526
9	18	USL1	Combination	630,509	1,975E-16	-144,303	8,044E-14	104,2910
9	19	USL1	Combination	-585,645	-1,975E-16	292,442	-1,014E-13	-99,1204
9	18	ULS2	Combination	433,995	1,975E-16	-128,834	-1,991E-15	178,1711
9	19	ULS2	Combination	-394,633	-1,975E-16	261,217	2,055E-15	-131,4680
9	18	SLS	Combination	467,044	1,463E-16	-106,891	5,959E-14	77,2526
9	19	SLS	Combination	-433,811	-1,463E-16	216,624	-7,508E-14	-73,4225
10	19	USL1	Combination	585,645	-1,539E-14	-292,442	7,034E-14	99,1204
10	20	USL1	Combination	-530,039	1,539E-14	466,295	-1,154E-13	-65,7881
10	19	ULS2	Combination	394,633	1,975E-16	-261,217	-2,055E-15	131,4680
10	20	ULS2	Combination	-350,267	-1,975E-16	416,564	2,156E-15	-36,9784
10	19	SLS	Combination	433,811	-1,140E-14	-216,624	5,210E-14	73,4225
10	20	SLS	Combination	-392,621	1,140E-14	345,403	-8,544E-14	-48,7319
11	20	USL1	Combination	530,039	-6,997E-15	-466,295	8,118E-14	65,7881
11	21	USL1	Combination	-459,271	6,997E-15	678,506	-8,165E-14	19,3013
11	20	ULS2	Combination	350,267	1,975E-16	-416,564	-2,156E-15	36,9784
11	21	ULS2	Combination	-298,850	-1,975E-16	607,673	2,287E-15	118,1679
11	20	SLS	Combination	392,621	-5,183E-15	-345,403	6,013E-14	48,7319
11	21	SLS	Combination	-340,201	5,183E-15	502,597	-6,048E-14	14,2973
12	21	USL1	Combination	459,271	3,017E-14	-678,506	1,128E-13	-19,3013
12	22	USL1	Combination	-370,531	-3,017E-14	943,195	-6,951E-14	303,2460
12	21	ULS2	Combination	298,850	1,975E-16	-607,673	-2,287E-15	-118,1679
12	22	ULS2	Combination	-237,098	-1,975E-16	845,375	2,430E-15	447,9675
12	21	SLS	Combination	340,201	2,235E-14	-502,597	8,357E-14	-14,2973
12	22	SLS	Combination	-274,468	-2,235E-14	698,663	-5,149E-14	224,6267
13	22	USL1	Combination	370,531	-1,101E-13	-943,195	8,570E-14	-303,2460
13	31	USL1	Combination	-253,454	1,101E-13	1279,642	-1,329E-13	944,6612
13	22	ULS2	Combination	237,098	1,975E-16	-845,375	-2,430E-15	-447,9675
13	31	ULS2	Combination	-157,603	-1,975E-16	1144,240	2,589E-15	1088,8473
13	22	SLS	Combination	274,468	-8,157E-14	-698,663	6,348E-14	-224,6267
13	31	SLS	Combination	-187,744	8,157E-14	947,883	-9,845E-14	699,7490
14	31	USL1	Combination	238,925	1,975E-16	-1279,642	3,578E-14	-944,6612
14	30	USL1	Combination	-107,574	-1,975E-16	1328,121	-1,123E-13	777,8974
14	31	ULS2	Combination	136,282	1,975E-16	-1144,240	-2,589E-15	-1088,8473
14	30	ULS2	Combination	-59,516	-1,975E-16	1192,718	2,777E-15	994,7215
14	31	SLS	Combination	176,981	1,463E-16	-947,883	2,650E-14	-699,7490
14	30	SLS	Combination	-79,684	-1,463E-16	983,793	-8,321E-14	576,2203
15	30	USL1	Combination	89,287	1,441E-13	-1328,121	7,876E-14	-777,8974
15	29	USL1	Combination	64,053	-1,441E-13	1376,599	4,133E-14	764,1345
15	30	ULS2	Combination	33,188	1,975E-16	-1192,718	-2,777E-15	-994,7215
15	29	ULS2	Combination	54,637	-1,975E-16	1241,196	2,965E-15	1004,0585
15	30	SLS	Combination	66,138	1,067E-13	-983,793	5,834E-14	-576,2203
15	29	SLS	Combination	47,446	-1,067E-13	1019,703	3,062E-14	566,0256
16	29	USL1	Combination	-84,641	6,734E-14	-1376,599	-2,695E-14	-764,1345
16	28	USL1	Combination	259,968	-6,734E-14	1425,077	7,989E-14	926,5079
16	29	ULS2	Combination	-83,993	1,975E-16	-1241,196	-2,965E-15	-1004,0585
16	28	ULS2	Combination	182,812	-1,975E-16	1289,675	3,153E-15	1130,2557
16	29	SLS	Combination	-62,697	4,988E-14	-1019,703	-1,996E-14	-566,0256
16	28	SLS	Combination	192,569	-4,988E-14	1055,613	5,918E-14	686,3021
18	27	USL1	Combination	374,872	5,889E-14	-267,419	2,860E-15	-346,4733
18	32	USL1	Combination	-155,568	-5,889E-14	291,659	6,219E-14	92,1081

Table: Element Joint Forces - Frames, Part 1 of 2

Frame	Joint	OutputCase	CaseType	F1 KN	F2 KN	F3 KN	M1 KN-m	M2 KN-m
18	27	ULS2	Combination	443,453	-3,461E-15	-196,906	-7,932E-15	-416,8491
18	32	ULS2	Combination	-322,582	3,461E-15	221,145	4,635E-15	51,1499
18	27	SLS	Combination	277,683	4,362E-14	-198,088	2,118E-15	-256,6469
18	32	SLS	Combination	-115,235	-4,362E-14	216,043	4,607E-14	68,2282
19	32	USL1	Combination	155,568	3,642E-14	-83,647	-4,540E-14	-92,1081
19	33	USL1	Combination	-155,568	-2,620E-14	19,615	4,540E-14	52,5773
19	32	ULS2	Combination	322,582	-3,461E-15	73,198	-4,635E-15	-51,1499
19	33	ULS2	Combination	-322,582	3,461E-15	-53,714	4,635E-15	99,7341
19	32	SLS	Combination	115,235	2,698E-14	-61,961	-3,363E-14	-68,2282
19	33	SLS	Combination	-115,235	-1,941E-14	14,530	3,363E-14	38,9462
20	33	USL1	Combination	155,568	3,497E-14	-19,615	-5,260E-14	-52,5773
20	9	USL1	Combination	-155,568	-2,525E-14	-41,210	5,260E-14	60,4304
20	33	ULS2	Combination	322,582	-3,461E-15	53,714	-4,635E-15	-99,7341
20	9	ULS2	Combination	-322,582	3,461E-15	-35,205	4,635E-15	132,0693
20	33	SLS	Combination	115,235	2,590E-14	-14,530	-3,896E-14	-38,9462
20	9	SLS	Combination	-115,235	-1,871E-14	-30,526	3,896E-14	44,7632
21	9	USL1	Combination	-698,079	-4,931E-14	-1002,438	-1,563E-13	7,9788
21	8	USL1	Combination	908,699	6,317E-14	948,510	1,192E-13	-225,1068
21	9	ULS2	Combination	-443,899	1,975E-16	-857,941	-3,529E-15	-105,0763
21	8	ULS2	Combination	580,754	-1,975E-16	889,790	3,658E-15	-224,2749
21	9	SLS	Combination	-517,096	-3,653E-14	-742,547	-1,157E-13	5,9103
21	8	SLS	Combination	673,110	4,679E-14	702,600	8,830E-14	-166,7457
22	8	USL1	Combination	-908,699	-5,848E-14	-748,544	-1,152E-13	225,1068
22	7	USL1	Combination	1112,776	7,315E-14	676,967	1,158E-13	-329,2715
22	8	ULS2	Combination	-580,754	1,975E-16	-604,951	-3,658E-15	224,2749
22	7	ULS2	Combination	724,244	-1,975E-16	636,698	3,758E-15	-429,6251
22	8	SLS	Combination	-673,110	-4,332E-14	-554,477	-8,530E-14	166,7457
22	7	SLS	Combination	824,278	5,419E-14	501,457	8,581E-14	-243,9048
23	7	USL1	Combination	-1112,776	-9,292E-14	-479,611	-1,059E-13	329,2715
23	6	USL1	Combination	1300,812	1,082E-13	392,972	8,735E-14	-361,6005
23	7	ULS2	Combination	-724,244	1,975E-16	-355,345	-3,758E-15	429,6251
23	6	ULS2	Combination	872,782	-1,975E-16	387,106	3,820E-15	-529,0178
23	7	SLS	Combination	-824,278	-6,883E-14	-355,267	-7,843E-14	243,9048
23	6	SLS	Combination	963,564	8,015E-14	291,090	6,470E-14	-267,8522
24	6	USL1	Combination	-1300,812	-6,121E-14	-197,335	-9,637E-14	361,6005
24	5	USL1	Combination	1474,519	7,751E-14	98,203	8,822E-14	-357,6641
24	6	ULS2	Combination	-872,782	1,975E-16	-108,168	-3,820E-15	529,0178
24	5	ULS2	Combination	1032,022	-1,975E-16	141,359	3,843E-15	-550,4571
24	6	SLS	Combination	-963,564	-4,534E-14	-146,174	-7,138E-14	267,8522
24	5	SLS	Combination	1092,237	5,742E-14	72,743	6,535E-14	-264,9363
25	5	USL1	Combination	-1474,519	-1,982E-13	96,930	-8,147E-14	357,6641
25	4	USL1	Combination	1307,511	2,139E-13	-192,577	1,023E-13	-359,3587
25	5	ULS2	Combination	-1032,022	1,975E-16	136,844	-3,843E-15	550,4571
25	4	ULS2	Combination	878,466	-1,975E-16	-104,839	3,822E-15	-530,2395
25	5	SLS	Combination	-1092,237	-1,468E-13	71,800	-6,035E-14	264,9363
25	4	SLS	Combination	968,527	1,584E-13	-142,649	7,576E-14	-266,1917
26	35	USL1	Combination	476,279	6,369E-14	-255,300	3,838E-14	-549,3701
26	27	USL1	Combination	-374,872	-6,369E-14	267,419	-1,661E-15	346,4733
26	35	ULS2	Combination	499,742	-3,461E-15	-184,786	-9,580E-15	-641,5554
26	27	ULS2	Combination	-443,453	3,461E-15	196,906	7,932E-15	416,8491
26	35	SLS	Combination	352,799	4,717E-14	-189,111	2,843E-14	-406,9408
26	27	SLS	Combination	-277,683	-4,717E-14	198,088	-1,230E-15	256,6469
27	4	USL1	Combination	-1307,511	9,099E-15	388,540	-9,924E-14	359,3587
27	3	USL1	Combination	1119,899	6,225E-15	-475,692	7,910E-14	-323,3804
27	4	ULS2	Combination	-878,466	1,975E-16	384,242	-3,822E-15	530,2395
27	3	ULS2	Combination	729,556	-1,975E-16	-352,402	3,761E-15	-428,4632
27	4	SLS	Combination	-968,527	6,740E-15	287,807	-7,351E-14	266,1917
27	3	SLS	Combination	829,555	4,611E-15	-352,364	5,859E-14	-239,5411
28	3	USL1	Combination	-1119,899	-1,123E-13	673,682	-1,159E-13	323,3804

Table: Element Joint Forces - Frames, Part 1 of 2

Frame	Joint	OutputCase	CaseType	F1 KN	F2 KN	F3 KN	M1 KN-m	M2 KN-m
28	2	USL1	Combination	915,713	1,270E-13	-745,963	1,386E-13	-216,4146
28	3	ULS2	Combination	-729,556	1,975E-16	634,674	-3,761E-15	428,4632
28	2	ULS2	Combination	585,487	-1,975E-16	-602,799	3,662E-15	-220,5937
28	3	SLS	Combination	-829,555	-8,317E-14	499,024	-8,584E-14	239,5411
28	2	SLS	Combination	678,306	9,408E-14	-552,565	1,026E-13	-160,3071
29	2	USL1	Combination	-915,713	-1,796E-14	946,843	-1,669E-13	216,4146
29	1	USL1	Combination	702,761	3,184E-14	-999,194	1,434E-13	-32,7460
29	2	ULS2	Combination	-585,487	1,975E-16	888,988	-3,662E-15	220,5937
29	1	ULS2	Combination	448,361	-1,975E-16	-857,076	3,529E-15	84,0134
29	2	SLS	Combination	-678,306	-1,330E-14	701,365	-1,236E-13	160,3071
29	1	SLS	Combination	520,564	2,358E-14	-740,144	1,062E-13	-24,2563
30	1	USL1	Combination	159,947	5,705E-15	-37,171	-4,842E-14	-51,3175
30	34	USL1	Combination	-159,947	4,523E-15	-26,861	4,842E-14	47,3704
30	1	ULS2	Combination	328,450	-1,807E-15	-28,765	-4,607E-16	-124,2338
30	34	ULS2	Combination	-328,450	1,807E-15	48,249	4,607E-16	94,7515
30	1	SLS	Combination	118,479	4,226E-15	-27,534	-3,587E-14	-38,0130
30	34	SLS	Combination	-118,479	3,351E-15	-19,897	3,587E-14	35,0892
31	34	USL1	Combination	159,947	-6,504E-14	26,861	-4,453E-14	-47,3704
31	10	USL1	Combination	-159,947	7,527E-14	-90,892	4,263E-14	92,4486
31	34	ULS2	Combination	328,450	-1,807E-15	-48,249	-4,607E-16	-94,7515
31	10	ULS2	Combination	-328,450	1,807E-15	67,733	4,607E-16	50,3514
31	34	SLS	Combination	118,479	-4,818E-14	19,897	-3,298E-14	-35,0892
31	10	SLS	Combination	-118,479	5,575E-14	-67,328	3,158E-14	68,4804
32	10	USL1	Combination	159,947	-7,261E-15	300,637	-5,470E-14	-92,4486
32	23	USL1	Combination	-379,251	1,932E-14	-276,398	5,376E-14	350,9851
32	10	ULS2	Combination	328,450	-1,807E-15	229,167	-4,607E-16	-50,3514
32	23	ULS2	Combination	-449,322	1,807E-15	-204,928	2,182E-15	421,6403
32	10	SLS	Combination	118,479	-5,378E-15	222,694	-4,052E-14	-68,4804
32	23	SLS	Combination	-280,927	1,431E-14	-204,739	3,982E-14	259,9890
34	24	USL1	Combination	-265,099	7,381E-14	1427,134	-1,708E-13	-939,0068
34	25	USL1	Combination	89,771	-6,444E-14	-1378,656	1,365E-13	771,7464
34	24	ULS2	Combination	-188,304	1,975E-16	1291,311	-3,153E-15	-1142,7945
34	25	ULS2	Combination	89,485	-1,975E-16	-1242,833	2,965E-15	1011,3663
34	24	SLS	Combination	-196,370	5,467E-14	1057,136	-1,265E-13	-695,5606
34	25	SLS	Combination	66,497	-4,773E-14	-1021,227	1,011E-13	571,6640
35	25	USL1	Combination	-68,777	5,521E-14	1378,656	-1,240E-13	-771,7464
35	26	USL1	Combination	-84,563	-4,719E-14	-1330,177	4,189E-14	781,0097
35	25	ULS2	Combination	-59,869	1,975E-16	1242,833	-2,965E-15	-1011,3663
35	26	ULS2	Combination	-27,956	-1,975E-16	-1194,354	2,777E-15	997,0458
35	25	SLS	Combination	-50,946	4,090E-14	1021,227	-9,185E-14	-571,6640
35	26	SLS	Combination	-62,639	-3,495E-14	-985,317	3,103E-14	578,5257
36	26	USL1	Combination	104,096	5,681E-14	1330,177	-5,590E-14	-781,0097
36	11	USL1	Combination	-235,447	-5,012E-14	-1281,699	-1,159E-14	944,4609
36	26	ULS2	Combination	55,818	1,975E-16	1194,354	-2,777E-15	-997,0458
36	11	ULS2	Combination	-132,584	-1,975E-16	-1145,876	2,589E-15	1087,6493
36	26	SLS	Combination	77,108	4,208E-14	985,317	-4,141E-14	-578,5257
36	11	SLS	Combination	-174,405	-3,713E-14	-949,407	-8,582E-15	699,6006
37	23	USL1	Combination	379,251	1,112E-14	276,398	-4,985E-14	-350,9851
37	36	USL1	Combination	-480,658	-5,599E-15	-264,278	6,484E-14	555,9675
37	23	ULS2	Combination	449,322	-1,807E-15	204,928	-2,182E-15	-421,6403
37	36	ULS2	Combination	-505,611	1,807E-15	-192,809	3,043E-15	649,1415
37	23	SLS	Combination	280,927	8,240E-15	204,739	-3,693E-14	-259,9890
37	36	SLS	Combination	-356,043	-4,147E-15	-195,762	4,803E-14	411,8278
38	36	USL1	Combination	-382,050	1,170E-13	1451,373	-2,189E-13	-1097,9004
38	24	USL1	Combination	286,141	-1,118E-13	-1427,134	1,713E-13	939,0068
38	36	ULS2	Combination	-271,201	1,975E-16	1315,550	-3,247E-15	-1259,0980
38	24	ULS2	Combination	217,677	-1,975E-16	-1291,311	3,153E-15	1142,7945
38	36	SLS	Combination	-283,000	8,668E-14	1075,091	-1,621E-13	-813,2596
38	24	SLS	Combination	211,956	-8,283E-14	-1057,136	1,269E-13	695,5606

Table: Element Joint Forces - Frames, Part 1 of 2

Frame	Joint	OutputCase	CaseType	F1 KN	F2 KN	F3 KN	M1 KN-m	M2 KN-m
39	1	USL1	Combination	-862,708	2,239E-14	1240,391	-1,143E-13	84,0635
39	36	USL1	Combination	862,708	-2,239E-14	-1187,095	8,354E-14	541,9329
39	1	ULS2	Combination	-776,812	2,005E-15	1176,038	-3,069E-15	40,2204
39	36	ULS2	Combination	776,812	-2,005E-15	-1122,742	2,041E-16	609,9566
39	1	SLS	Combination	-639,043	1,658E-14	918,808	-8,465E-14	62,2693
39	36	SLS	Combination	639,043	-1,658E-14	-879,330	6,188E-14	401,4318
40	9	USL1	Combination	853,647	-2,764E-14	1246,604	9,302E-14	-68,4092
40	35	USL1	Combination	-853,647	2,764E-14	-1194,017	-6,081E-14	-533,8015
40	9	ULS2	Combination	766,481	-3,659E-15	1181,714	-1,106E-15	-26,9929
40	35	ULS2	Combination	-766,481	3,659E-15	-1129,127	6,333E-15	-602,8788
40	9	SLS	Combination	632,331	-2,047E-14	923,410	6,890E-14	-50,6735
40	35	SLS	Combination	-632,331	2,047E-14	-884,457	-4,505E-14	-395,4085

Table: Element Joint Forces - Frames, Part 2 of 2

Table: Element Joint Forces - Frames, Part 2 of 2

Frame	Joint	OutputCase	M3 KN-m	FrameElem
1	28	USL1	1,574E-13	1-1
1	35	USL1	-1,574E-13	1-1
1	28	ULS2	-8,262E-16	1-1
1	35	ULS2	8,262E-16	1-1
1	28	SLS	1,166E-13	1-1
1	35	SLS	-1,166E-13	1-1
2	11	USL1	-1,055E-13	2-1
2	12	USL1	1,980E-13	2-1
2	11	ULS2	1,188E-15	2-1
2	12	ULS2	-1,026E-15	2-1
2	11	SLS	-7,817E-14	2-1
2	12	SLS	1,467E-13	2-1
3	12	USL1	-1,788E-13	3-1
3	13	USL1	2,389E-13	3-1
3	12	ULS2	1,026E-15	3-1
3	13	ULS2	-8,829E-16	3-1
3	12	SLS	-1,325E-13	3-1
3	13	SLS	1,770E-13	3-1
4	13	USL1	-2,443E-13	4-1
4	14	USL1	2,271E-13	4-1
4	13	ULS2	8,829E-16	4-1
4	14	ULS2	-7,383E-16	4-1
4	13	SLS	-1,810E-13	4-1
4	14	SLS	1,682E-13	4-1
5	14	USL1	-1,950E-13	5-1
5	15	USL1	2,704E-13	5-1
5	14	ULS2	7,383E-16	5-1
5	15	ULS2	-5,708E-16	5-1
5	14	SLS	-1,444E-13	5-1
5	15	SLS	2,003E-13	5-1
6	15	USL1	-1,355E-13	6-1
6	16	USL1	1,075E-13	6-1
6	15	ULS2	5,708E-16	6-1
6	16	ULS2	-3,861E-16	6-1
6	15	SLS	-1,004E-13	6-1
6	16	SLS	7,965E-14	6-1
7	16	USL1	-1,060E-13	7-1
7	17	USL1	-2,776E-14	7-1
7	16	ULS2	3,861E-16	7-1
7	17	ULS2	-1,808E-16	7-1

Table: Element Joint Forces - Frames, Part 2 of 2

Frame	Joint	OutputCase	M3 KN-m	FrameElem
7	16	SLS	-7,854E-14	7-1
7	17	SLS	-2,056E-14	7-1
8	17	USL1	2,251E-14	8-1
8	18	USL1	-4,074E-14	8-1
8	17	ULS2	1,808E-16	8-1
8	18	ULS2	3,180E-17	8-1
8	17	SLS	1,668E-14	8-1
8	18	SLS	-3,017E-14	8-1
9	18	USL1	4,913E-14	9-1
9	19	USL1	-4,295E-14	9-1
9	18	ULS2	-3,180E-17	9-1
9	19	ULS2	2,155E-16	9-1
9	18	SLS	3,639E-14	9-1
9	19	SLS	-3,181E-14	9-1
10	19	USL1	-3,229E-14	10-1
10	20	USL1	-4,758E-14	10-1
10	19	ULS2	-2,155E-16	10-1
10	20	ULS2	3,816E-16	10-1
10	19	SLS	-2,392E-14	10-1
10	20	SLS	-3,524E-14	10-1
11	20	USL1	4,578E-14	11-1
11	21	USL1	-1,147E-14	11-1
11	20	ULS2	-3,816E-16	11-1
11	21	ULS2	5,249E-16	11-1
11	20	SLS	3,391E-14	11-1
11	21	SLS	-8,493E-15	11-1
12	21	USL1	3,365E-14	12-1
12	22	USL1	-6,888E-14	12-1
12	21	ULS2	-5,249E-16	12-1
12	22	ULS2	6,672E-16	12-1
12	21	SLS	2,492E-14	12-1
12	22	SLS	-5,102E-14	12-1
13	22	USL1	1,192E-13	13-1
13	31	USL1	-1,407E-13	13-1
13	22	ULS2	-6,672E-16	13-1
13	31	ULS2	8,262E-16	13-1
13	22	SLS	8,832E-14	13-1
13	31	SLS	-1,042E-13	13-1
14	31	USL1	1,646E-13	14-1
14	30	USL1	-1,646E-13	14-1
14	31	ULS2	-8,262E-16	14-1
14	30	ULS2	8,262E-16	14-1
14	31	SLS	1,220E-13	14-1
14	30	SLS	-1,220E-13	14-1
15	30	USL1	1,646E-13	15-1
15	29	USL1	-1,646E-13	15-1
15	30	ULS2	-8,262E-16	15-1
15	29	ULS2	8,262E-16	15-1
15	30	SLS	1,220E-13	15-1
15	29	SLS	-1,220E-13	15-1
16	29	USL1	1,646E-13	16-1
16	28	USL1	-1,646E-13	16-1
16	29	ULS2	-8,262E-16	16-1
16	28	ULS2	8,262E-16	16-1
16	29	SLS	1,220E-13	16-1
16	28	SLS	-1,220E-13	16-1
18	27	USL1	6,510E-14	18-1
18	32	USL1	-6,510E-14	18-1
18	27	ULS2	7,546E-15	18-1

Table: Element Joint Forces - Frames, Part 2 of 2

Frame	Joint	OutputCase	M3 KN-m	FrameElem
18	32	ULS2	-7,546E-15	18-1
18	27	SLS	4,822E-14	18-1
18	32	SLS	-4,822E-14	18-1
19	32	USL1	8,183E-14	19-1
19	33	USL1	-9,297E-14	19-1
19	32	ULS2	7,546E-15	19-1
19	33	ULS2	-4,896E-15	19-1
19	32	SLS	6,062E-14	19-1
19	33	SLS	-6,887E-14	19-1
20	33	USL1	9,184E-14	20-1
20	9	USL1	-1,241E-13	20-1
20	33	ULS2	4,896E-15	20-1
20	9	ULS2	-2,379E-15	20-1
20	33	SLS	6,803E-14	20-1
20	9	SLS	-9,192E-14	20-1
21	9	USL1	2,558E-13	21-1
21	8	USL1	-2,242E-13	21-1
21	9	ULS2	-5,312E-16	21-1
21	8	ULS2	3,813E-16	21-1
21	9	SLS	1,895E-13	21-1
21	8	SLS	-1,660E-13	21-1
22	8	USL1	2,510E-13	22-1
22	7	USL1	-2,290E-13	22-1
22	8	ULS2	-3,813E-16	22-1
22	7	ULS2	2,112E-16	22-1
22	8	SLS	1,859E-13	22-1
22	7	SLS	-1,696E-13	22-1
23	7	USL1	3,001E-13	23-1
23	6	USL1	-1,906E-13	23-1
23	7	ULS2	-2,112E-16	23-1
23	6	ULS2	2,412E-17	23-1
23	7	SLS	2,223E-13	23-1
23	6	SLS	-1,412E-13	23-1
24	6	USL1	1,985E-13	24-1
24	5	USL1	-9,949E-14	24-1
24	6	ULS2	-2,412E-17	24-1
24	5	ULS2	-1,808E-16	24-1
24	6	SLS	1,470E-13	24-1
24	5	SLS	-7,370E-14	24-1
25	5	USL1	8,010E-14	25-1
25	4	USL1	2,491E-14	25-1
25	5	ULS2	1,808E-16	25-1
25	4	ULS2	-3,784E-16	25-1
25	5	SLS	5,934E-14	25-1
25	4	SLS	1,845E-14	25-1
26	35	USL1	6,630E-14	26-1
26	27	USL1	-6,630E-14	26-1
26	35	ULS2	7,546E-15	26-1
26	27	ULS2	-7,546E-15	26-1
26	35	SLS	4,911E-14	26-1
26	27	SLS	-4,911E-14	26-1
27	4	USL1	-9,586E-14	27-1
27	3	USL1	7,739E-14	27-1
27	4	ULS2	3,784E-16	27-1
27	3	ULS2	-5,665E-16	27-1
27	4	SLS	-7,101E-14	27-1
27	3	SLS	5,732E-14	27-1
28	3	USL1	-9,852E-14	28-1
28	2	USL1	2,090E-13	28-1

Table: Element Joint Forces - Frames, Part 2 of 2

Frame	Joint	OutputCase	M3 KN-m	FrameElem
28	3	ULS2	5,665E-16	28-1
28	2	ULS2	-7,379E-16	28-1
28	3	SLS	-7,298E-14	28-1
28	2	SLS	1,548E-13	28-1
29	2	USL1	-1,656E-13	29-1
29	1	USL1	1,295E-13	29-1
29	2	ULS2	7,379E-16	29-1
29	1	ULS2	-8,852E-16	29-1
29	2	SLS	-1,227E-13	29-1
29	1	SLS	9,591E-14	29-1
30	1	USL1	-4,908E-14	30-1
30	34	USL1	1,929E-14	30-1
30	1	ULS2	-4,629E-16	30-1
30	34	ULS2	1,847E-15	30-1
30	1	SLS	-3,635E-14	30-1
30	34	SLS	1,429E-14	30-1
31	34	USL1	-6,845E-14	31-1
31	10	USL1	9,501E-14	31-1
31	34	ULS2	-1,847E-15	31-1
31	10	ULS2	3,230E-15	31-1
31	34	SLS	-5,070E-14	31-1
31	10	SLS	7,038E-14	31-1
32	10	USL1	-4,040E-14	32-1
32	23	USL1	4,040E-14	32-1
32	10	ULS2	-3,230E-15	32-1
32	23	ULS2	3,230E-15	32-1
32	10	SLS	-2,993E-14	32-1
32	23	SLS	2,993E-14	32-1
34	24	USL1	-1,283E-13	34-1
34	25	USL1	1,235E-13	34-1
34	24	ULS2	1,188E-15	34-1
34	25	ULS2	-1,188E-15	34-1
34	24	SLS	-9,504E-14	34-1
34	25	SLS	9,149E-14	34-1
35	25	USL1	-1,307E-13	35-1
35	26	USL1	1,307E-13	35-1
35	25	ULS2	1,188E-15	35-1
35	26	ULS2	-1,188E-15	35-1
35	25	SLS	-9,682E-14	35-1
35	26	SLS	9,682E-14	35-1
36	26	USL1	-1,235E-13	36-1
36	11	USL1	1,235E-13	36-1
36	26	ULS2	1,188E-15	36-1
36	11	ULS2	-1,188E-15	36-1
36	26	SLS	-9,149E-14	36-1
36	11	SLS	9,149E-14	36-1
37	23	USL1	-4,160E-14	37-1
37	36	USL1	4,160E-14	37-1
37	23	ULS2	-3,230E-15	37-1
37	36	ULS2	3,230E-15	37-1
37	23	SLS	-3,081E-14	37-1
37	36	SLS	3,081E-14	37-1
38	36	USL1	-1,187E-13	38-1
38	24	USL1	1,187E-13	38-1
38	36	ULS2	1,188E-15	38-1
38	24	ULS2	-1,188E-15	38-1
38	36	SLS	-8,794E-14	38-1
38	24	SLS	8,794E-14	38-1
39	1	USL1	-9,428E-14	39-1

Table: Element Joint Forces - Frames, Part 2 of 2

Frame	Joint	OutputCase	M3 KN-m	FrameElem
39	36	USL1	8,131E-14	39-1
39	1	ULS2	1,348E-15	39-1
39	36	ULS2	-4,418E-15	39-1
39	1	SLS	-6,983E-14	39-1
39	36	SLS	6,023E-14	39-1
40	9	USL1	-1,426E-13	40-1
40	35	USL1	1,031E-13	40-1
40	9	ULS2	2,910E-15	40-1
40	35	ULS2	-8,372E-15	40-1
40	9	SLS	-1,056E-13	40-1
40	35	SLS	7,640E-14	40-1

Table: Frame Loads - Distributed, Part 1 of 3

Table: Frame Loads - Distributed, Part 1 of 3

Frame	LoadPat	CoordSys	Type	Dir	DistType	RelDistA
2	HYDROSTATIC	Local	Force	2	RelDist	0,0000
2	EARTH	GLOBAL	Force	Gravity	RelDist	0,0000
2	EARTH_PRESSURE SX	GLOBAL	Force	X	RelDist	0,0000
3	HYDROSTATIC	Local	Force	2	RelDist	0,0000
3	EARTH	GLOBAL	Force	Gravity	RelDist	0,0000
3	EARTH_PRESSURE SX	GLOBAL	Force	X	RelDist	0,0000
4	HYDROSTATIC	Local	Force	2	RelDist	0,0000
4	EARTH	GLOBAL	Force	Gravity	RelDist	0,0000
4	EARTH_PRESSURE SX	GLOBAL	Force	X	RelDist	0,0000
5	HYDROSTATIC	Local	Force	2	RelDist	0,0000
5	EARTH	GLOBAL	Force	Gravity	RelDist	0,0000
5	EARTH_PRESSURE SX	GLOBAL	Force	X	RelDist	0,0000
6	HYDROSTATIC	Local	Force	2	RelDist	0,0000
6	EARTH	GLOBAL	Force	Gravity	RelDist	0,0000
6	EARTH_PRESSURE SX	GLOBAL	Force	X	RelDist	0,0000
7	HYDROSTATIC	Local	Force	2	RelDist	0,0000
7	EARTH	GLOBAL	Force	Gravity	RelDist	0,0000
7	EARTH_PRESSURE SX	GLOBAL	Force	X	RelDist	0,0000
8	HYDROSTATIC	Local	Force	2	RelDist	0,0000
8	EARTH	GLOBAL	Force	Gravity	RelDist	0,0000
8	EARTH_PRESSURE DX	GLOBAL	Force	X	RelDist	0,0000
9	HYDROSTATIC	Local	Force	2	RelDist	0,0000
9	EARTH	GLOBAL	Force	Gravity	RelDist	0,0000
9	EARTH_PRESSURE DX	GLOBAL	Force	X	RelDist	0,0000
10	HYDROSTATIC	Local	Force	2	RelDist	0,0000
10	EARTH	GLOBAL	Force	Gravity	RelDist	0,0000
10	EARTH_PRESSURE DX	GLOBAL	Force	X	RelDist	0,0000
11	HYDROSTATIC	Local	Force	2	RelDist	0,0000
11	EARTH	GLOBAL	Force	Gravity	RelDist	0,0000
11	EARTH_PRESSURE DX	GLOBAL	Force	X	RelDist	0,0000
12	HYDROSTATIC	Local	Force	2	RelDist	0,0000
12	EARTH	GLOBAL	Force	Gravity	RelDist	0,0000

Table: Frame Loads - Distributed, Part 1 of 3

Frame	LoadPat	CoordSys	Type	Dir	DistType	RelDistA
12	EARTH_PRESSURE DX	GLOBAL	Force	X	RelDist	0,0000
13	HYDROSTATIC	Local	Force	2	RelDist	0,0000
13	EARTH	GLOBAL	Force	Gravity	RelDist	0,0000
13	EARTH_PRESSURE DX	GLOBAL	Force	X	RelDist	0,0000
14	HYDROSTATIC	Local	Force	2	RelDist	0,0000
14	EARTH_PRESSURE DX	GLOBAL	Force	X	RelDist	0,0000
15	HYDROSTATIC	Local	Force	2	RelDist	0,0000
15	EARTH_PRESSURE DX	GLOBAL	Force	X	RelDist	0,0000
16	HYDROSTATIC	Local	Force	2	RelDist	0,0000
16	EARTH_PRESSURE DX	GLOBAL	Force	X	RelDist	0,0000
18	HYDROSTATIC	Local	Force	2	RelDist	0,0000
18	EARTH_PRESSURE DX	GLOBAL	Force	X	RelDist	0,0000
19	HYDROSTATIC	Local	Force	2	RelDist	0,0000
20	HYDROSTATIC	Local	Force	2	RelDist	0,0000
21	HYDROSTATIC	Local	Force	2	RelDist	0,0000
21	EARTH_PRESSURE DX	GLOBAL	Force	X	RelDist	0,0000
22	HYDROSTATIC	Local	Force	2	RelDist	0,0000
22	EARTH_PRESSURE DX	GLOBAL	Force	X	RelDist	0,0000
23	HYDROSTATIC	Local	Force	2	RelDist	0,0000
23	EARTH_PRESSURE DX	GLOBAL	Force	X	RelDist	0,0000
24	HYDROSTATIC	Local	Force	2	RelDist	0,0000
24	EARTH_PRESSURE DX	GLOBAL	Force	X	RelDist	0,0000
25	HYDROSTATIC	Local	Force	2	RelDist	0,0000
25	EARTH_PRESSURE SX	GLOBAL	Force	X	RelDist	0,0000
27	HYDROSTATIC	Local	Force	2	RelDist	0,0000
27	EARTH_PRESSURE SX	GLOBAL	Force	X	RelDist	0,0000
28	HYDROSTATIC	Local	Force	2	RelDist	0,0000
28	EARTH_PRESSURE SX	GLOBAL	Force	X	RelDist	0,0000
29	HYDROSTATIC	Local	Force	2	RelDist	0,0000
29	EARTH_PRESSURE SX	GLOBAL	Force	X	RelDist	0,0000
30	HYDROSTATIC	Local	Force	2	RelDist	0,0000
31	HYDROSTATIC	Local	Force	2	RelDist	0,0000
32	HYDROSTATIC	Local	Force	2	RelDist	0,0000
32	EARTH_PRESSURE SX	GLOBAL	Force	X	RelDist	0,0000
34	HYDROSTATIC	Local	Force	2	RelDist	0,0000
34	EARTH_PRESSURE SX	GLOBAL	Force	X	RelDist	0,0000
35	HYDROSTATIC	Local	Force	2	RelDist	0,0000
35	EARTH_PRESSURE SX	GLOBAL	Force	X	RelDist	0,0000
36	HYDROSTATIC	Local	Force	2	RelDist	0,0000
36	EARTH_PRESSURE SX	GLOBAL	Force	X	RelDist	0,0000
1	EARTH_PRESSURE DX	GLOBAL	Force	X	RelDist	0,0000
1	HYDROSTATIC	Local	Force	2	RelDist	0,0000

Table: Frame Loads - Distributed, Part 1 of 3

Frame	LoadPat	CoordSys	Type	Dir	DistType	RelDistA
26	EARTH_PRESSURE DX	GLOBAL	Force	X	RelDist	0,0000
26	HYDROSTATIC	Local	Force	2	RelDist	0,0000
37	EARTH_PRESSURE SX	GLOBAL	Force	X	RelDist	0,0000
37	HYDROSTATIC	Local	Force	2	RelDist	0,0000
38	EARTH_PRESSURE SX	GLOBAL	Force	X	RelDist	0,0000
38	HYDROSTATIC	Local	Force	2	RelDist	0,0000

Table: Frame Loads - Distributed, Part 2 of 3

Table: Frame Loads - Distributed, Part 2 of 3

Frame	LoadPat	RelDistB	AbsDistA m	AbsDistB m	FOverLA KN/m	FOverLB KN/m
2	HYDROSTATIC	1,0000	0,00000	1,15723	-38,20	-31,00
2	EARTH	1,0000	0,00000	1,15723	51,50	51,50
2	EARTH_PRESSURE SX	1,0000	0,00000	1,15723	55,40	48,10
3	HYDROSTATIC	1,0000	0,00000	1,02464	-31,00	-24,50
3	EARTH	1,0000	0,00000	1,02464	47,40	47,40
3	EARTH_PRESSURE SX	1,0000	0,00000	1,02464	48,10	41,70
4	HYDROSTATIC	1,0000	0,00000	0,98945	-24,50	-18,60
4	EARTH	1,0000	0,00000	0,98945	39,70	39,70
4	EARTH_PRESSURE SX	1,0000	0,00000	0,98945	41,70	35,70
5	HYDROSTATIC	1,0000	0,00000	0,98804	-18,60	-14,00
5	EARTH	1,0000	0,00000	0,98804	32,70	32,70
5	EARTH_PRESSURE SX	1,0000	0,00000	0,98804	35,70	31,10
6	HYDROSTATIC	1,0000	0,00000	0,98763	-14,00	-11,10
6	EARTH	1,0000	0,00000	0,98763	26,90	26,90
6	EARTH_PRESSURE SX	1,0000	0,00000	0,98763	31,10	28,10
7	HYDROSTATIC	1,0000	0,00000	1,04617	-11,10	-10,00
7	EARTH	1,0000	0,00000	1,04617	22,80	22,80
7	EARTH_PRESSURE SX	1,0000	0,00000	1,04617	28,10	27,00
8	HYDROSTATIC	1,0000	0,00000	1,08329	-10,00	-11,10
8	EARTH	1,0000	0,00000	1,08329	22,80	22,80
8	EARTH_PRESSURE DX	1,0000	0,00000	1,08329	-27,00	-28,10
9	HYDROSTATIC	1,0000	0,00000	0,98504	-11,10	-14,00
9	EARTH	1,0000	0,00000	0,98504	26,90	26,90
9	EARTH_PRESSURE DX	1,0000	0,00000	0,98504	-28,10	-31,10
10	HYDROSTATIC	1,0000	0,00000	0,98394	-14,00	-18,60
10	EARTH	1,0000	0,00000	0,98394	32,70	32,70
10	EARTH_PRESSURE DX	1,0000	0,00000	0,98394	-31,10	-35,70
11	HYDROSTATIC	1,0000	0,00000	0,98416	-18,60	-24,50
11	EARTH	1,0000	0,00000	0,98416	39,70	39,70
11	EARTH_PRESSURE DX	1,0000	0,00000	0,98416	-35,70	-41,70
12	HYDROSTATIC	1,0000	0,00000	1,01876	-24,50	-31,00
12	EARTH	1,0000	0,00000	1,01876	47,40	47,40
12	EARTH_PRESSURE DX	1,0000	0,00000	1,01876	-41,70	-48,10
13	HYDROSTATIC	1,0000	0,00000	1,13787	-31,00	-38,20

Table: Frame Loads - Distributed, Part 2 of 3

Frame	LoadPat	RelDistB	AbsDistA m	AbsDistB m	FOverLA KN/m	FOverLB KN/m
13	EARTH	1,0000	0,00000	1,13787	51,50	51,50
13	EARTH_PRESSURE DX	1,0000	0,00000	1,13787	-48,10	-55,40
14	HYDROSTATIC	1,0000	0,00000	0,95249	-38,20	-46,70
14	EARTH_PRESSURE DX	1,0000	0,00000	0,95249	-55,40	-64,00
15	HYDROSTATIC	1,0000	0,00000	0,95249	-46,70	-55,20
15	EARTH_PRESSURE DX	1,0000	0,00000	0,95249	-64,00	-72,60
16	HYDROSTATIC	1,0000	0,00000	0,95249	-55,20	-63,80
16	EARTH_PRESSURE DX	1,0000	0,00000	0,95249	-72,60	-81,10
18	HYDROSTATIC	1,0000	0,00000	0,95249	-72,30	-80,80
18	EARTH_PRESSURE DX	1,0000	0,00000	0,95249	-89,70	-98,30
19	HYDROSTATIC	1,0000	0,00000	0,76564	-80,80	-80,80
20	HYDROSTATIC	1,0000	0,00000	0,72730	-80,80	-80,80
21	HYDROSTATIC	1,0000	0,00000	1,00122	-80,80	-86,60
21	EARTH_PRESSURE DX	1,0000	0,00000	1,00122	-98,30	-104,20
22	HYDROSTATIC	1,0000	0,00000	0,99802	-86,60	-91,20
22	EARTH_PRESSURE DX	1,0000	0,00000	0,99802	-104,20	-108,80
23	HYDROSTATIC	1,0000	0,00000	0,99844	-91,20	-94,00
23	EARTH_PRESSURE DX	1,0000	0,00000	0,99844	-108,80	-111,60
24	HYDROSTATIC	1,0000	0,00000	1,04339	-94,00	-95,00
24	EARTH_PRESSURE DX	1,0000	0,00000	1,04339	-111,60	-114,50
25	HYDROSTATIC	1,0000	0,00000	1,00615	-95,00	-94,00
25	EARTH_PRESSURE SX	1,0000	0,00000	1,00615	114,50	111,60
27	HYDROSTATIC	1,0000	0,00000	1,00094	-94,00	-91,20
27	EARTH_PRESSURE SX	1,0000	0,00000	1,00094	111,60	108,80
28	HYDROSTATIC	1,0000	0,00000	1,00204	-91,20	-86,60
28	EARTH_PRESSURE SX	1,0000	0,00000	1,00204	108,80	104,20
29	HYDROSTATIC	1,0000	0,00000	1,00321	-86,60	-80,80
29	EARTH_PRESSURE SX	1,0000	0,00000	1,00321	104,20	98,30
30	HYDROSTATIC	1,0000	0,00000	0,76564	-80,80	-80,80
31	HYDROSTATIC	1,0000	0,00000	0,76564	-80,80	-80,80
32	HYDROSTATIC	1,0000	0,00000	0,95249	-80,80	-72,30
32	EARTH_PRESSURE SX	1,0000	0,00000	0,95249	98,30	89,70
34	HYDROSTATIC	1,0000	0,00000	0,95249	-63,80	-55,20
34	EARTH_PRESSURE SX	1,0000	0,00000	0,95249	81,10	72,60
35	HYDROSTATIC	1,0000	0,00000	0,95249	-55,20	-46,70
35	EARTH_PRESSURE SX	1,0000	0,00000	0,95249	72,60	64,00
36	HYDROSTATIC	1,0000	0,00000	0,95249	-46,70	-38,20
36	EARTH_PRESSURE SX	1,0000	0,00000	0,95249	64,00	55,40
1	EARTH_PRESSURE DX	1,0000	0,00000	0,47625	-81,10	-85,40
1	HYDROSTATIC	1,0000	0,00000	0,47625	-63,80	-68,05
26	EARTH_PRESSURE DX	1,0000	0,00000	0,47625	-85,40	-89,70
26	HYDROSTATIC	1,0000	0,00000	0,47625	-68,05	-72,30

Table: Frame Loads - Distributed, Part 2 of 3

Frame	LoadPat	RelDistB	AbsDistA m	AbsDistB m	FOverLA KN/m	FOverLB KN/m
37	EARTH_PRESSURE SX	1,0000	0,00000	0,47625	89,70	85,40
37	HYDROSTATIC	1,0000	0,00000	0,47625	-72,30	-68,05
38	EARTH_PRESSURE SX	1,0000	0,00000	0,47625	85,40	81,10
38	HYDROSTATIC	1,0000	0,00000	0,47625	-68,05	-63,80

Table: Frame Loads - Distributed, Part 3 of 3

Table: Frame Loads - Distributed, Part 3 of 3

Frame	LoadPat	GUID
2	HYDROSTATIC	
2	EARTH	
2	EARTH_PRESSURE SX	
3	HYDROSTATIC	
3	EARTH	
3	EARTH_PRESSURE SX	
4	HYDROSTATIC	
4	EARTH	
4	EARTH_PRESSURE SX	
5	HYDROSTATIC	
5	EARTH	
5	EARTH_PRESSURE SX	
6	HYDROSTATIC	
6	EARTH	
6	EARTH_PRESSURE SX	
7	HYDROSTATIC	
7	EARTH	
7	EARTH_PRESSURE SX	
8	HYDROSTATIC	
8	EARTH	
8	EARTH_PRESSURE DX	
9	HYDROSTATIC	
9	EARTH	
9	EARTH_PRESSURE DX	
10	HYDROSTATIC	
10	EARTH	
10	EARTH_PRESSURE DX	
11	HYDROSTATIC	
11	EARTH	
11	EARTH_PRESSURE DX	
12	HYDROSTATIC	
12	EARTH	
12	EARTH_PRESSURE DX	
13	HYDROSTATIC	
13	EARTH	
13	EARTH_PRESSURE DX	

Table: Frame Loads - Distributed, Part 3 of 3

Frame	LoadPat	GUID
14	HYDROSTATIC	
14	EARTH_PRESSURE DX	
15	HYDROSTATIC	
15	EARTH_PRESSURE DX	
16	HYDROSTATIC	
16	EARTH_PRESSURE DX	
18	HYDROSTATIC	
18	EARTH_PRESSURE DX	
19	HYDROSTATIC	
20	HYDROSTATIC	
21	HYDROSTATIC	
21	EARTH_PRESSURE DX	
22	HYDROSTATIC	
22	EARTH_PRESSURE DX	
23	HYDROSTATIC	
23	EARTH_PRESSURE DX	
24	HYDROSTATIC	
24	EARTH_PRESSURE DX	
25	HYDROSTATIC	
25	EARTH_PRESSURE SX	
27	HYDROSTATIC	
27	EARTH_PRESSURE SX	
28	HYDROSTATIC	
28	EARTH_PRESSURE SX	
29	HYDROSTATIC	
29	EARTH_PRESSURE SX	
30	HYDROSTATIC	
31	HYDROSTATIC	
32	HYDROSTATIC	
32	EARTH_PRESSURE SX	
34	HYDROSTATIC	
34	EARTH_PRESSURE SX	
35	HYDROSTATIC	
35	EARTH_PRESSURE SX	
36	HYDROSTATIC	
36	EARTH_PRESSURE SX	
1	EARTH_PRESSURE DX	
1	HYDROSTATIC	
26	EARTH_PRESSURE DX	
26	HYDROSTATIC	
37	EARTH_PRESSURE SX	
37	HYDROSTATIC	

Table: Frame Loads - Distributed, Part 3 of 3

Frame	LoadPat	GUID
38	EARTH_PRESSURE SX	
38	HYDROSTATIC	

Table: Joint Spring Assignments 1 - Uncoupled

Table: Joint Spring Assignments 1 - Uncoupled

Joint	CoordSys	U1	U2	U3	R1	R2	R3
		KN/m	KN/m	KN/m	KN-m/rad	KN-m/rad	KN-m/rad
1	Local	0,00	0,00	6787,00	0,0000	0,0000	0,0000
2	Local	0,00	0,00	6787,00	0,0000	0,0000	0,0000
3	Local	0,00	0,00	6787,00	0,0000	0,0000	0,0000
4	Local	0,00	0,00	6787,00	0,0000	0,0000	0,0000
5	Local	0,00	0,00	6787,00	0,0000	0,0000	0,0000
6	Local	0,00	0,00	6787,00	0,0000	0,0000	0,0000
7	Local	0,00	0,00	6787,00	0,0000	0,0000	0,0000
8	Local	0,00	0,00	6787,00	0,0000	0,0000	0,0000
9	Local	0,00	0,00	6787,00	0,0000	0,0000	0,0000
10	Local	0,00	0,00	6787,00	0,0000	0,0000	0,0000
11	Local	19780,00	0,00	0,00	0,0000	0,0000	0,0000
24	Local	19780,00	0,00	0,00	0,0000	0,0000	0,0000
25	Local	19780,00	0,00	0,00	0,0000	0,0000	0,0000
26	Local	19780,00	0,00	0,00	0,0000	0,0000	0,0000
28	Local	19780,00	0,00	0,00	0,0000	0,0000	0,0000
29	Local	19780,00	0,00	0,00	0,0000	0,0000	0,0000
30	Local	19780,00	0,00	0,00	0,0000	0,0000	0,0000
31	Local	19780,00	0,00	0,00	0,0000	0,0000	0,0000
32	Local	0,00	0,00	6787,00	0,0000	0,0000	0,0000

Table: Load Pattern Definitions

Table: Load Pattern Definitions

LoadPat	DesignType	SelfWtMult	AutoLoad	GUID	Notes
DEAD	DEAD	1,000000			
EARTH	DEAD	0,000000			
EARTH_PRESSURE DX	DEAD	0,000000			
EARTH_PRESSURE SX	DEAD	0,000000			
HYDROSTATIC	DEAD	0,000000			

Table: Combination Definitions, Part 1 of 3

Table: Combination Definitions, Part 1 of 3

ComboName	ComboType	AutoDesign	CaseType	CaseName	ScaleFactor	SteelDesign
USL1	Linear Add	No	Linear Static	EARTH	1,000000	None
USL1			Linear Static	EARTH_PRESSURE DX	1,000000	
USL1			Linear Static	HYDROSTATIC	1,000000	
USL1			Linear Static	DEAD	1,000000	
USL1			Linear Static	INERTIA	1,000000	
USL1			Linear Static	DINAMIC EARTH PRESSURE	1,000000	
ULS2	Linear Add	No	Linear Static	DEAD	1,000000	None
ULS2			Linear Static	EARTH	1,000000	
ULS2			Linear Static	EARTH_PRESSURE DX	1,000000	
ULS2			Linear Static	DINAMIC EARTH PRESSURE	1,000000	
USL2	Envelope	No	Linear Static	INERTIA	1,000000	None
ENVELOPE_ULS			Response Combo	ULS2	1,000000	
ENVELOPE_ULS			Response Combo	USL1	1,000000	

Table: Combination Definitions, Part 2 of 3

Table: Combination Definitions, Part 2 of 3

ComboName	CaseName	ConcDesign	AlumDesign	ColdDesign
USL1	EARTH	None	None	None
USL1	EARTH_PRESSURE DX			
USL1	HYDROSTATIC			
USL1	DEAD			
USL1	INERTIA			
USL1	DINAMIC EARTH PRESSURE			
ULS2	DEAD	None	None	None
ULS2	EARTH			
ULS2	EARTH_PRESSURE DX			
ULS2	DINAMIC EARTH PRESSURE			
USL2	INERTIA			
ENVELOPE_ULS	ULS2	None	None	None
ENVELOPE_ULS	USL1			

Table: Combination Definitions, Part 3 of 3

Table: Combination Definitions, Part 3 of 3

ComboName	CaseName	GUID	Notes
USL1	EARTH		
USL1	EARTH_PRESSURE DX		
USL1	HYDROSTATIC		
USL1	DEAD		
USL1	INERTIA		
USL1	DINAMIC EARTH PRESSURE		

Table: Combination Definitions, Part 3 of 3

ComboName	CaseName	GUID	Notes
ULS2	DEAD		
ULS2	EARTH		
ULS2	EARTH_PRESSURE DX		
ULS2	DINAMIC EARTH PRESSURE		
ULS2	INERTIA		
ENVELOPE_ULS	ULS2		
ENVELOPE_ULS	USL1		

Table: Element Forces - Frames, Part 1 of 2

Table: Element Forces - Frames, Part 1 of 2

Frame	Station m	OutputCase	CaseType	StepType	P KN	V2 KN	V3 KN	T KN-m
1	0,00000	USL1	Combination		-1009,600	214,060	3,102E-17	1,208E-13
1	0,23812	USL1	Combination		-1018,578	254,787	3,102E-17	1,208E-13
1	0,47625	USL1	Combination		-1027,555	296,533	3,102E-17	1,208E-13
1	0,00000	ULS2	Combination		-909,154	151,088	3,102E-17	-3,113E-17
1	0,23812	ULS2	Combination		-918,132	176,371	3,102E-17	-3,113E-17
1	0,47625	ULS2	Combination		-927,109	202,166	3,102E-17	-3,113E-17
1	0,00000	ENVELOPE_ ULS	Combination	Max	-909,154	214,060	3,102E-17	1,208E-13
1	0,23812	ENVELOPE_ ULS	Combination	Max	-918,132	254,787	3,102E-17	1,208E-13
1	0,47625	ENVELOPE_ ULS	Combination	Max	-927,109	296,533	3,102E-17	1,208E-13
1	0,00000	ENVELOPE_ ULS	Combination	Min	-1009,600	151,088	3,102E-17	-3,113E-17
1	0,23812	ENVELOPE_ ULS	Combination	Min	-1018,578	176,371	3,102E-17	-3,113E-17
1	0,47625	ENVELOPE_ ULS	Combination	Min	-1027,555	202,166	3,102E-17	-3,113E-17
2	0,00000	USL1	Combination		-1374,639	-33,097	3,102E-17	6,853E-14
2	0,57862	USL1	Combination		-1295,037	67,567	3,102E-17	6,853E-14
2	1,15723	USL1	Combination		-1215,435	166,147	3,102E-17	6,853E-14
2	0,00000	ULS2	Combination		-1245,413	-20,248	3,102E-17	-2,528E-15
2	0,57862	ULS2	Combination		-1165,811	59,354	3,102E-17	-2,528E-15
2	1,15723	ULS2	Combination		-1086,209	138,956	3,102E-17	-2,528E-15
2	0,00000	ENVELOPE_ ULS	Combination	Max	-1245,413	-20,248	3,102E-17	6,853E-14
2	0,57862	ENVELOPE_ ULS	Combination	Max	-1165,811	67,567	3,102E-17	6,853E-14
2	1,15723	ENVELOPE_ ULS	Combination	Max	-1086,209	166,147	3,102E-17	6,853E-14
2	0,00000	ENVELOPE_ ULS	Combination	Min	-1374,639	-33,097	3,102E-17	-2,528E-15
2	0,57862	ENVELOPE_ ULS	Combination	Min	-1295,037	59,354	3,102E-17	-2,528E-15
2	1,15723	ENVELOPE_ ULS	Combination	Min	-1215,435	138,956	3,102E-17	-2,528E-15
3	0,00000	USL1	Combination		-1195,283	145,995	-5,681E-14	7,208E-14
3	0,51232	USL1	Combination		-1132,672	223,655	-5,681E-14	7,208E-14
3	1,02464	USL1	Combination		-1070,061	299,651	-5,681E-14	7,208E-14
3	0,00000	ULS2	Combination		-1066,056	118,803	3,102E-17	-2,528E-15
3	0,51232	ULS2	Combination		-1003,445	181,414	3,102E-17	-2,528E-15
3	1,02464	ULS2	Combination		-940,834	244,025	3,102E-17	-2,528E-15
3	0,00000	ENVELOPE_ ULS	Combination	Max	-1066,056	145,995	3,102E-17	7,208E-14
3	0,51232	ENVELOPE_ ULS	Combination	Max	-1003,445	223,655	3,102E-17	7,208E-14

Table: Element Forces - Frames, Part 1 of 2

Frame	Station m	OutputCase	CaseType	StepType	P KN	V2 KN	V3 KN	T KN-m
3	1,02464	ENVELOPE_ ULS	Combination	Max	-940,834	299,651	3,102E-17	7,208E-14
3	0,00000	ENVELOPE_ ULS	Combination	Min	-1195,283	118,803	-5,681E-14	-2,528E-15
3	0,51232	ENVELOPE_ ULS	Combination	Min	-1132,672	181,414	-5,681E-14	-2,528E-15
3	1,02464	ENVELOPE_ ULS	Combination	Min	-1070,061	244,025	-5,681E-14	-2,528E-15
4	0,00000	USL1	Combination		-1061,950	229,542	2,845E-14	2,579E-14
4	0,49473	USL1	Combination		-1014,066	293,575	2,845E-14	2,579E-14
4	0,98945	USL1	Combination		-966,182	356,149	2,845E-14	2,579E-14
4	0,00000	ULS2	Combination		-930,238	180,089	3,102E-17	-2,629E-15
4	0,49473	ULS2	Combination		-882,354	232,731	3,102E-17	-2,629E-15
4	0,98945	ULS2	Combination		-834,470	285,373	3,102E-17	-2,629E-15
4	0,00000	ENVELOPE_ ULS	Combination	Max	-930,238	229,542	2,845E-14	2,579E-14
4	0,49473	ENVELOPE_ ULS	Combination	Max	-882,354	293,575	2,845E-14	2,579E-14
4	0,98945	ENVELOPE_ ULS	Combination	Max	-834,470	356,149	2,845E-14	2,579E-14
4	0,00000	ENVELOPE_ ULS	Combination	Min	-1061,950	180,089	3,102E-17	-2,629E-15
4	0,49473	ENVELOPE_ ULS	Combination	Min	-1014,066	232,731	3,102E-17	-2,629E-15
4	0,98945	ENVELOPE_ ULS	Combination	Min	-966,182	285,373	3,102E-17	-2,629E-15
5	0,00000	USL1	Combination		-993,095	143,269	5,687E-14	-9,210E-15
5	0,49402	USL1	Combination		-963,446	201,477	5,687E-14	-9,210E-15
5	0,98804	USL1	Combination		-933,797	258,550	5,687E-14	-9,210E-15
5	0,00000	ULS2	Combination		-849,981	99,959	3,102E-17	-2,993E-15
5	0,49402	ULS2	Combination		-820,332	149,547	3,102E-17	-2,993E-15
5	0,98804	ULS2	Combination		-790,683	199,135	3,102E-17	-2,993E-15
5	0,00000	ENVELOPE_ ULS	Combination	Max	-849,981	143,269	5,687E-14	-2,993E-15
5	0,49402	ENVELOPE_ ULS	Combination	Max	-820,332	201,477	5,687E-14	-2,993E-15
5	0,98804	ENVELOPE_ ULS	Combination	Max	-790,683	258,550	5,687E-14	-2,993E-15
5	0,00000	ENVELOPE_ ULS	Combination	Min	-993,095	99,959	3,102E-17	-9,210E-15
5	0,49402	ENVELOPE_ ULS	Combination	Min	-963,446	149,547	3,102E-17	-9,210E-15
5	0,98804	ENVELOPE_ ULS	Combination	Min	-933,797	199,135	3,102E-17	-9,210E-15
6	0,00000	USL1	Combination		-940,235	48,473	-5,681E-14	-4,056E-14
6	0,49382	USL1	Combination		-924,383	101,562	-5,681E-14	-4,056E-14
6	0,98763	USL1	Combination		-908,532	153,936	-5,681E-14	-4,056E-14
6	0,00000	ULS2	Combination		-787,863	20,284	3,102E-17	-3,255E-15
6	0,49382	ULS2	Combination		-772,012	66,818	3,102E-17	-3,255E-15
6	0,98763	ULS2	Combination		-756,161	113,351	3,102E-17	-3,255E-15
6	0,00000	ENVELOPE_ ULS	Combination	Max	-787,863	48,473	3,102E-17	-3,255E-15
6	0,49382	ENVELOPE_ ULS	Combination	Max	-772,012	101,562	3,102E-17	-3,255E-15
6	0,98763	ENVELOPE_ ULS	Combination	Max	-756,161	153,936	3,102E-17	-3,255E-15
6	0,00000	ENVELOPE_ ULS	Combination	Min	-940,235	20,284	-5,681E-14	-4,056E-14
6	0,49382	ENVELOPE_ ULS	Combination	Min	-924,383	66,818	-5,681E-14	-4,056E-14
6	0,98763	ENVELOPE_ ULS	Combination	Min	-908,532	113,351	-5,681E-14	-4,056E-14
7	0,00000	USL1	Combination		-892,054	-48,258	-1,705E-13	-6,555E-14

Table: Element Forces - Frames, Part 1 of 2

Frame	Station m	OutputCase	CaseType	StepType	P KN	V2 KN	V3 KN	T KN-m
7	0,52308	USL1	Combination		-886,975	2,760	-1,705E-13	-6,555E-14
7	1,04617	USL1	Combination		-881,895	53,491	-1,705E-13	-6,555E-14
7	0,00000	ULS2	Combination		-734,520	-55,118	3,102E-17	-3,381E-15
7	0,52308	ULS2	Combination		-729,441	-9,763	3,102E-17	-3,381E-15
7	1,04617	ULS2	Combination		-724,361	35,593	3,102E-17	-3,381E-15
7	0,00000	ENVELOPE_ ULS	Combination	Max	-734,520	-48,258	3,102E-17	-3,381E-15
7	0,52308	ENVELOPE_ ULS	Combination	Max	-729,441	2,760	3,102E-17	-3,381E-15
7	1,04617	ENVELOPE_ ULS	Combination	Max	-724,361	53,491	3,102E-17	-3,381E-15
7	0,00000	ENVELOPE_ ULS	Combination	Min	-892,054	-55,118	-1,705E-13	-6,555E-14
7	0,52308	ENVELOPE_ ULS	Combination	Min	-886,975	-9,763	-1,705E-13	-6,555E-14
7	1,04617	ENVELOPE_ ULS	Combination	Min	-881,895	35,593	-1,705E-13	-6,555E-14
8	0,00000	USL1	Combination		-842,995	-143,095	-5,681E-14	-7,441E-14
8	0,54165	USL1	Combination		-820,854	-87,385	-5,681E-14	-7,441E-14
8	1,08329	USL1	Combination		-798,416	-31,343	-5,681E-14	-7,441E-14
8	0,00000	ULS2	Combination		-685,475	-125,075	3,102E-17	-3,351E-15
8	0,54165	ULS2	Combination		-663,334	-74,931	3,102E-17	-3,351E-15
8	1,08329	ULS2	Combination		-640,896	-24,752	3,102E-17	-3,351E-15
8	0,00000	ENVELOPE_ ULS	Combination	Max	-685,475	-125,075	3,102E-17	-3,351E-15
8	0,54165	ENVELOPE_ ULS	Combination	Max	-663,334	-74,931	3,102E-17	-3,351E-15
8	1,08329	ENVELOPE_ ULS	Combination	Max	-640,896	-24,752	3,102E-17	-3,351E-15
8	0,00000	ENVELOPE_ ULS	Combination	Min	-842,995	-143,095	-5,681E-14	-7,441E-14
8	0,54165	ENVELOPE_ ULS	Combination	Min	-820,854	-87,385	-5,681E-14	-7,441E-14
8	1,08329	ENVELOPE_ ULS	Combination	Min	-798,416	-31,343	-5,681E-14	-7,441E-14
9	0,00000	USL1	Combination		-745,327	-195,803	3,102E-17	-5,468E-14
9	0,49252	USL1	Combination		-736,918	-135,108	3,102E-17	-5,468E-14
9	0,98504	USL1	Combination		-727,812	-73,455	3,102E-17	-5,468E-14
9	0,00000	ULS2	Combination		-593,062	-154,922	3,102E-17	-3,164E-15
9	0,49252	ULS2	Combination		-584,653	-100,051	3,102E-17	-3,164E-15
9	0,98504	ULS2	Combination		-575,546	-44,936	3,102E-17	-3,164E-15
9	0,00000	ENVELOPE_ ULS	Combination	Max	-593,062	-154,922	3,102E-17	-3,164E-15
9	0,49252	ENVELOPE_ ULS	Combination	Max	-584,653	-100,051	3,102E-17	-3,164E-15
9	0,98504	ENVELOPE_ ULS	Combination	Max	-575,546	-44,936	3,102E-17	-3,164E-15
9	0,00000	ENVELOPE_ ULS	Combination	Min	-745,327	-195,803	3,102E-17	-5,468E-14
9	0,49252	ENVELOPE_ ULS	Combination	Min	-736,918	-135,108	3,102E-17	-5,468E-14
9	0,98504	ENVELOPE_ ULS	Combination	Min	-727,812	-73,455	3,102E-17	-5,468E-14
10	0,00000	USL1	Combination		-672,184	-208,662	3,102E-17	-6,502E-14
10	0,49197	USL1	Combination		-678,401	-137,667	3,102E-17	-6,502E-14
10	0,98394	USL1	Combination		-683,651	-64,953	3,102E-17	-6,502E-14
10	0,00000	ULS2	Combination		-529,200	-149,049	3,102E-17	-2,850E-15
10	0,49197	ULS2	Combination		-535,417	-85,507	3,102E-17	-2,850E-15
10	0,98394	ULS2	Combination		-540,667	-21,378	3,102E-17	-2,850E-15
10	0,00000	ENVELOPE_ ULS	Combination	Max	-529,200	-149,049	3,102E-17	-2,850E-15

Table: Element Forces - Frames, Part 1 of 2

Frame	Station m	OutputCase	CaseType	StepType	P KN	V2 KN	V3 KN	T KN-m
10	0,49197	ENVELOPE_ ULS	Combination	Max	-535,417	-85,507	3,102E-17	-2,850E-15
10	0,98394	ENVELOPE_ ULS	Combination	Max	-540,667	-21,378	3,102E-17	-2,850E-15
10	0,00000	ENVELOPE_ ULS	Combination	Min	-672,184	-208,662	3,102E-17	-6,502E-14
10	0,49197	ENVELOPE_ ULS	Combination	Min	-678,401	-137,667	3,102E-17	-6,502E-14
10	0,98394	ENVELOPE_ ULS	Combination	Min	-683,651	-64,953	3,102E-17	-6,502E-14
11	0,00000	USL1	Combination		-636,849	-177,778	-5,681E-14	-4,153E-14
11	0,49208	USL1	Combination		-662,491	-95,378	-5,681E-14	-4,153E-14
11	0,98416	USL1	Combination		-687,045	-10,529	-5,681E-14	-4,153E-14
11	0,00000	ULS2	Combination		-505,109	-107,154	3,102E-17	-2,449E-15
11	0,49208	ULS2	Combination		-530,751	-34,632	3,102E-17	-2,449E-15
11	0,98416	ULS2	Combination		-555,305	38,887	3,102E-17	-2,449E-15
11	0,00000	ENVELOPE_ ULS	Combination	Max	-505,109	-107,154	3,102E-17	-2,449E-15
11	0,49208	ENVELOPE_ ULS	Combination	Max	-530,751	-34,632	3,102E-17	-2,449E-15
11	0,98416	ENVELOPE_ ULS	Combination	Max	-555,305	38,887	3,102E-17	-2,449E-15
11	0,00000	ENVELOPE_ ULS	Combination	Min	-636,849	-177,778	-5,681E-14	-4,153E-14
11	0,49208	ENVELOPE_ ULS	Combination	Min	-662,491	-95,378	-5,681E-14	-4,153E-14
11	0,98416	ENVELOPE_ ULS	Combination	Min	-687,045	-10,529	-5,681E-14	-4,153E-14
12	0,00000	USL1	Combination		-665,794	-20,086	3,102E-17	-9,454E-15
12	0,50938	USL1	Combination		-703,805	79,714	3,102E-17	-9,454E-15
12	1,01876	USL1	Combination		-740,664	182,322	3,102E-17	-9,454E-15
12	0,00000	ULS2	Combination		-536,315	34,982	3,102E-17	-2,349E-15
12	0,50938	ULS2	Combination		-574,326	121,475	3,102E-17	-2,349E-15
12	1,01876	ULS2	Combination		-611,185	209,120	3,102E-17	-2,349E-15
12	0,00000	ENVELOPE_ ULS	Combination	Max	-536,315	34,982	3,102E-17	-2,349E-15
12	0,50938	ENVELOPE_ ULS	Combination	Max	-574,326	121,475	3,102E-17	-2,349E-15
12	1,01876	ENVELOPE_ ULS	Combination	Max	-611,185	209,120	3,102E-17	-2,349E-15
12	0,00000	ENVELOPE_ ULS	Combination	Min	-665,794	-20,086	3,102E-17	-9,454E-15
12	0,50938	ENVELOPE_ ULS	Combination	Min	-703,805	79,714	3,102E-17	-9,454E-15
12	1,01876	ENVELOPE_ ULS	Combination	Min	-740,664	182,322	3,102E-17	-9,454E-15
13	0,00000	USL1	Combination		-720,511	202,475	3,102E-17	1,541E-14
13	0,56894	USL1	Combination		-769,042	329,146	3,102E-17	1,541E-14
13	1,13787	USL1	Combination		-816,103	459,334	3,102E-17	1,541E-14
13	0,00000	ULS2	Combination		-591,033	229,272	3,102E-17	-2,349E-15
13	0,56894	ULS2	Combination		-639,563	337,283	3,102E-17	-2,349E-15
13	1,13787	ULS2	Combination		-686,625	446,761	3,102E-17	-2,349E-15
13	0,00000	ENVELOPE_ ULS	Combination	Max	-591,033	229,272	3,102E-17	1,541E-14
13	0,56894	ENVELOPE_ ULS	Combination	Max	-639,563	337,283	3,102E-17	1,541E-14
13	1,13787	ENVELOPE_ ULS	Combination	Max	-686,625	459,334	3,102E-17	1,541E-14
13	0,00000	ENVELOPE_ ULS	Combination	Min	-720,511	202,475	3,102E-17	-2,349E-15
13	0,56894	ENVELOPE_ ULS	Combination	Min	-769,042	329,146	3,102E-17	-2,349E-15

Table: Element Forces - Frames, Part 1 of 2

Frame	Station m	OutputCase	CaseType	StepType	P KN	V2 KN	V3 KN	T KN-m
13	1,13787	ENVELOPE_	Combination	Min	-816,103	446,761	3,102E-17	-2,349E-15
		ULS						
14	0,00000	USL1	Combination		-901,870	-223,774	3,102E-17	1,225E-13
14	0,47625	USL1	Combination		-919,825	-165,732	3,102E-17	1,225E-13
14	0,95249	USL1	Combination		-937,780	-103,617	3,102E-17	1,225E-13
14	0,00000	ULS2	Combination		-801,425	-141,109	3,102E-17	-3,113E-17
14	0,47625	ULS2	Combination		-819,380	-102,271	3,102E-17	-3,113E-17
14	0,95249	ULS2	Combination		-837,335	-61,386	3,102E-17	-3,113E-17
14	0,00000	ENVELOPE_	Combination	Max	-801,425	-141,109	3,102E-17	1,225E-13
		ULS						
14	0,47625	ENVELOPE_	Combination	Max	-819,380	-102,271	3,102E-17	1,225E-13
		ULS						
14	0,95249	ENVELOPE_	Combination	Max	-837,335	-61,386	3,102E-17	1,225E-13
		ULS						
14	0,00000	ENVELOPE_	Combination	Min	-901,870	-223,774	3,102E-17	-3,113E-17
		ULS						
14	0,47625	ENVELOPE_	Combination	Min	-919,825	-165,732	3,102E-17	-3,113E-17
		ULS						
14	0,95249	ENVELOPE_	Combination	Min	-937,780	-103,617	3,102E-17	-3,113E-17
		ULS						
15	0,00000	USL1	Combination		-937,780	-94,117	1,137E-13	1,225E-13
15	0,47625	USL1	Combination		-955,735	-27,931	1,137E-13	1,225E-13
15	0,95249	USL1	Combination		-973,690	42,327	1,137E-13	1,225E-13
15	0,00000	ULS2	Combination		-837,335	-51,886	3,102E-17	-3,113E-17
15	0,47625	ULS2	Combination		-855,290	-8,952	3,102E-17	-3,113E-17
15	0,95249	ULS2	Combination		-873,244	36,029	3,102E-17	-3,113E-17
15	0,00000	ENVELOPE_	Combination	Max	-837,335	-51,886	1,137E-13	1,225E-13
		ULS						
15	0,47625	ENVELOPE_	Combination	Max	-855,290	-8,952	1,137E-13	1,225E-13
		ULS						
15	0,95249	ENVELOPE_	Combination	Max	-873,244	42,327	1,137E-13	1,225E-13
		ULS						
15	0,00000	ENVELOPE_	Combination	Min	-937,780	-94,117	3,102E-17	-3,113E-17
		ULS						
15	0,47625	ENVELOPE_	Combination	Min	-955,735	-27,931	3,102E-17	-3,113E-17
		ULS						
15	0,95249	ENVELOPE_	Combination	Min	-973,690	36,029	3,102E-17	-3,113E-17
		ULS						
16	0,00000	USL1	Combination		-973,690	51,827	3,102E-17	1,190E-13
16	0,47625	USL1	Combination		-991,645	126,157	3,102E-17	1,190E-13
16	0,95249	USL1	Combination		-1009,600	204,560	3,102E-17	1,190E-13
16	0,00000	ULS2	Combination		-873,244	45,529	3,102E-17	-3,113E-17
16	0,47625	ULS2	Combination		-891,199	92,547	3,102E-17	-3,113E-17
16	0,95249	ULS2	Combination		-909,154	141,588	3,102E-17	-3,113E-17
16	0,00000	ENVELOPE_	Combination	Max	-873,244	51,827	3,102E-17	1,190E-13
		ULS						
16	0,47625	ENVELOPE_	Combination	Max	-891,199	126,157	3,102E-17	1,190E-13
		ULS						
16	0,95249	ENVELOPE_	Combination	Max	-909,154	204,560	3,102E-17	1,190E-13
		ULS						
16	0,00000	ENVELOPE_	Combination	Min	-973,690	45,529	3,102E-17	-3,113E-17
		ULS						
16	0,47625	ENVELOPE_	Combination	Min	-991,645	92,547	3,102E-17	-3,113E-17
		ULS						
16	0,95249	ENVELOPE_	Combination	Min	-1009,600	141,588	3,102E-17	-3,113E-17
		ULS						
18	0,00000	USL1	Combination		-389,009	-61,867	4,777E-14	4,300E-14
18	0,47625	USL1	Combination		-397,986	28,750	4,777E-14	4,300E-14
18	0,95249	USL1	Combination		-406,963	123,440	4,777E-14	4,300E-14
18	0,00000	ULS2	Combination		-332,845	-122,269	-1,965E-15	1,704E-15
18	0,47625	ULS2	Combination		-341,823	-67,096	-1,965E-15	1,704E-15
18	0,95249	ULS2	Combination		-350,800	-9,875	-1,965E-15	1,704E-15

Table: Element Forces - Frames, Part 1 of 2

Frame	Station m	OutputCase	CaseType	StepType	P KN	V2 KN	V3 KN	T KN-m
18	0,00000	ENVELOPE_ ULS	Combination	Max	-332,845	-61,867	4,777E-14	4,300E-14
18	0,47625	ENVELOPE_ ULS	Combination	Max	-341,823	28,750	4,777E-14	4,300E-14
18	0,95249	ENVELOPE_ ULS	Combination	Max	-350,800	123,440	4,777E-14	4,300E-14
18	0,00000	ENVELOPE_ ULS	Combination	Min	-389,009	-122,269	-1,965E-15	1,704E-15
18	0,47625	ENVELOPE_ ULS	Combination	Min	-397,986	-67,096	-1,965E-15	1,704E-15
18	0,95249	ENVELOPE_ ULS	Combination	Min	-406,963	-9,875	-1,965E-15	1,704E-15
19	0,00000	USL1	Combination		-132,940	-214,372	-2,771E-14	-2,877E-14
19	0,38282	USL1	Combination		-132,940	-190,657	-2,859E-14	-2,877E-14
19	0,76564	USL1	Combination		-132,940	-166,941	-2,947E-14	-2,877E-14
19	0,00000	ULS2	Combination		0,375	-94,159	-1,350E-14	1,432E-15
19	0,38282	ULS2	Combination		0,375	-101,376	-1,438E-14	1,432E-15
19	0,76564	ULS2	Combination		0,375	-108,592	-1,526E-14	1,432E-15
19	0,00000	ENVELOPE_ ULS	Combination	Max	0,375	-94,159	-1,350E-14	1,432E-15
19	0,38282	ENVELOPE_ ULS	Combination	Max	0,375	-101,376	-1,438E-14	1,432E-15
19	0,76564	ENVELOPE_ ULS	Combination	Max	0,375	-108,592	-1,526E-14	1,432E-15
19	0,00000	ENVELOPE_ ULS	Combination	Min	-132,940	-214,372	-2,771E-14	-2,877E-14
19	0,38282	ENVELOPE_ ULS	Combination	Min	-132,940	-190,657	-2,859E-14	-2,877E-14
19	0,76564	ENVELOPE_ ULS	Combination	Min	-132,940	-166,941	-2,947E-14	-2,877E-14
20	0,00000	USL1	Combination		-142,440	-166,941	4,158E-14	-3,410E-14
20	0,36365	USL1	Combination		-142,440	-144,413	4,074E-14	-3,410E-14
20	0,72730	USL1	Combination		-142,440	-121,885	3,990E-14	-3,410E-14
20	0,00000	ULS2	Combination		-9,125	-108,592	-1,526E-14	1,432E-15
20	0,36365	ULS2	Combination		-9,125	-115,447	-1,610E-14	1,432E-15
20	0,72730	ULS2	Combination		-9,125	-122,302	-1,694E-14	1,432E-15
20	0,00000	ENVELOPE_ ULS	Combination	Max	-9,125	-108,592	4,158E-14	1,432E-15
20	0,36365	ENVELOPE_ ULS	Combination	Max	-9,125	-115,447	4,074E-14	1,432E-15
20	0,72730	ENVELOPE_ ULS	Combination	Max	-9,125	-121,885	3,990E-14	1,432E-15
20	0,00000	ENVELOPE_ ULS	Combination	Min	-142,440	-166,941	-1,526E-14	-3,410E-14
20	0,36365	ENVELOPE_ ULS	Combination	Min	-142,440	-144,413	-1,610E-14	-3,410E-14
20	0,72730	ENVELOPE_ ULS	Combination	Min	-142,440	-122,302	-1,694E-14	-3,410E-14
21	0,00000	USL1	Combination		-878,383	-76,843	-4,386E-14	5,213E-14
21	0,50061	USL1	Combination		-933,055	-4,210	-4,001E-14	5,213E-14
21	1,00122	USL1	Combination		-988,846	70,838	-3,604E-14	5,213E-14
21	0,00000	ULS2	Combination		-656,254	-126,355	-1,544E-14	2,393E-15
21	0,50061	ULS2	Combination		-710,926	-94,897	-1,159E-14	2,393E-15
21	1,00122	ULS2	Combination		-766,717	-62,477	-7,620E-15	2,393E-15
21	0,00000	ENVELOPE_ ULS	Combination	Max	-656,254	-76,843	-1,544E-14	5,213E-14
21	0,50061	ENVELOPE_ ULS	Combination	Max	-710,926	-4,210	-1,159E-14	5,213E-14
21	1,00122	ENVELOPE_ ULS	Combination	Max	-766,717	70,838	-7,620E-15	5,213E-14
21	0,00000	ENVELOPE_ ULS	Combination	Min	-878,383	-126,355	-4,386E-14	2,393E-15

Table: Element Forces - Frames, Part 1 of 2

Frame	Station m	OutputCase	CaseType	StepType	P KN	V2 KN	V3 KN	T KN-m
21	0,50061	ENVELOPE_	Combination	Min	-933,055	-94,897	-4,001E-14	2,393E-15
		ULS						
21	1,00122	ENVELOPE_	Combination	Min	-988,846	-62,477	-3,604E-14	2,393E-15
		ULS						
22	0,00000	USL1	Combination		-907,581	44,518	-2,750E-14	2,225E-14
22	0,49901	USL1	Combination		-969,209	110,812	-2,474E-14	2,225E-14
22	0,99802	USL1	Combination		-1031,827	178,835	-2,191E-14	2,225E-14
22	0,00000	ULS2	Combination		-633,408	7,290	9,237E-16	2,713E-15
22	0,49901	ULS2	Combination		-695,036	29,796	3,680E-15	2,713E-15
22	0,99802	ULS2	Combination		-757,655	52,883	6,507E-15	2,713E-15
22	0,00000	ENVELOPE_	Combination	Max	-633,408	44,518	9,237E-16	2,225E-14
		ULS						
22	0,49901	ENVELOPE_	Combination	Max	-695,036	110,812	3,680E-15	2,225E-14
		ULS						
22	0,99802	ENVELOPE_	Combination	Max	-757,655	178,835	6,507E-15	2,225E-14
		ULS						
22	0,00000	ENVELOPE_	Combination	Min	-907,581	7,290	-2,750E-14	2,713E-15
		ULS						
22	0,49901	ENVELOPE_	Combination	Min	-969,209	29,796	-2,474E-14	2,713E-15
		ULS						
22	0,99802	ENVELOPE_	Combination	Min	-1031,827	52,883	-2,191E-14	2,713E-15
		ULS						
23	0,00000	USL1	Combination		-1003,781	119,632	4,217E-14	-7,690E-15
23	0,49922	USL1	Combination		-1070,724	175,442	4,339E-14	-7,690E-15
23	0,99844	USL1	Combination		-1138,330	232,172	4,463E-14	-7,690E-15
23	0,00000	ULS2	Combination		-689,834	112,020	1,375E-14	2,968E-15
23	0,49922	ULS2	Combination		-756,777	121,952	1,497E-14	2,968E-15
23	0,99844	ULS2	Combination		-824,383	132,106	1,621E-14	2,968E-15
23	0,00000	ENVELOPE_	Combination	Max	-689,834	119,632	4,217E-14	2,968E-15
		ULS						
23	0,49922	ENVELOPE_	Combination	Max	-756,777	175,442	4,339E-14	2,968E-15
		ULS						
23	0,99844	ENVELOPE_	Combination	Max	-824,383	232,172	4,463E-14	2,968E-15
		ULS						
23	0,00000	ENVELOPE_	Combination	Min	-1003,781	112,020	1,375E-14	-7,690E-15
		ULS						
23	0,49922	ENVELOPE_	Combination	Min	-1070,724	121,952	1,497E-14	-7,690E-15
		ULS						
23	0,99844	ENVELOPE_	Combination	Min	-1138,330	132,106	1,621E-14	-7,690E-15
		ULS						
24	0,00000	USL1	Combination		-1154,096	142,984	-6,408E-14	-4,843E-14
24	0,52170	USL1	Combination		-1226,131	187,664	-6,463E-14	-4,843E-14
24	1,04339	USL1	Combination		-1298,918	232,687	-6,517E-14	-4,843E-14
24	0,00000	ULS2	Combination		-819,398	172,752	2,119E-14	3,089E-15
24	0,52170	ULS2	Combination		-891,433	168,262	2,064E-14	3,089E-15
24	1,04339	ULS2	Combination		-964,220	163,854	2,010E-14	3,089E-15
24	0,00000	ENVELOPE_	Combination	Max	-819,398	172,752	2,119E-14	3,089E-15
		ULS						
24	0,52170	ENVELOPE_	Combination	Max	-891,433	187,664	2,064E-14	3,089E-15
		ULS						
24	1,04339	ENVELOPE_	Combination	Max	-964,220	232,687	2,010E-14	3,089E-15
		ULS						
24	0,00000	ENVELOPE_	Combination	Min	-1154,096	142,984	-6,408E-14	-4,843E-14
		ULS						
24	0,52170	ENVELOPE_	Combination	Min	-1226,131	168,262	-6,463E-14	-4,843E-14
		ULS						
24	1,04339	ENVELOPE_	Combination	Min	-1298,918	163,854	-6,517E-14	-4,843E-14
		ULS						
25	0,00000	USL1	Combination		-1343,829	99,370	-3,671E-14	-6,089E-14
25	0,50307	USL1	Combination		-1342,587	135,248	-3,815E-14	-6,089E-14
25	1,00615	USL1	Combination		-1341,345	170,874	-3,959E-14	-6,089E-14
25	0,00000	ULS2	Combination		-1008,579	164,181	2,014E-14	3,063E-15

Table: Element Forces - Frames, Part 1 of 2

Frame	Station m	OutputCase	CaseType	StepType	P KN	V2 KN	V3 KN	T KN-m
25	0,50307	ULS2	Combination		-1007,337	152,392	1,869E-14	3,063E-15
25	1,00615	ULS2	Combination		-1006,094	140,603	1,725E-14	3,063E-15
25	0,00000	ENVELOPE_ ULS	Combination	Max	-1008,579	164,181	2,014E-14	3,063E-15
25	0,50307	ENVELOPE_ ULS	Combination	Max	-1007,337	152,392	1,869E-14	3,063E-15
25	1,00615	ENVELOPE_ ULS	Combination	Max	-1006,094	170,874	1,725E-14	3,063E-15
25	0,00000	ENVELOPE_ ULS	Combination	Min	-1343,829	99,370	-3,671E-14	-6,089E-14
25	0,50307	ENVELOPE_ ULS	Combination	Min	-1342,587	135,248	-3,815E-14	-6,089E-14
25	1,00615	ENVELOPE_ ULS	Combination	Min	-1341,345	140,603	-3,959E-14	-6,089E-14
26	0,00000	USL1	Combination		-380,031	-157,913	5,843E-14	4,434E-14
26	0,23812	USL1	Combination		-384,520	-115,149	5,843E-14	4,434E-14
26	0,47625	USL1	Combination		-389,009	-71,367	5,843E-14	4,434E-14
26	0,00000	ULS2	Combination		-323,868	-184,895	-1,965E-15	1,704E-15
26	0,23812	ULS2	Combination		-328,357	-158,588	-1,965E-15	1,704E-15
26	0,47625	ULS2	Combination		-332,845	-131,769	-1,965E-15	1,704E-15
26	0,00000	ENVELOPE_ ULS	Combination	Max	-323,868	-157,913	5,843E-14	4,434E-14
26	0,23812	ENVELOPE_ ULS	Combination	Max	-328,357	-115,149	5,843E-14	4,434E-14
26	0,47625	ENVELOPE_ ULS	Combination	Max	-332,845	-71,367	5,843E-14	4,434E-14
26	0,00000	ENVELOPE_ ULS	Combination	Min	-380,031	-184,895	-1,965E-15	1,704E-15
26	0,23812	ENVELOPE_ ULS	Combination	Min	-384,520	-158,588	-1,965E-15	1,704E-15
26	0,47625	ENVELOPE_ ULS	Combination	Min	-389,009	-131,769	-1,965E-15	1,704E-15
27	0,00000	USL1	Combination		-1400,581	20,547	-4,220E-14	-3,974E-14
27	0,50047	USL1	Combination		-1396,933	56,027	-4,358E-14	-3,974E-14
27	1,00094	USL1	Combination		-1393,286	90,806	-4,495E-14	-3,974E-14
27	0,00000	ULS2	Combination		-1085,442	119,305	1,464E-14	2,896E-15
27	0,50047	ULS2	Combination		-1081,795	108,091	1,327E-14	2,896E-15
27	1,00094	ULS2	Combination		-1078,147	96,876	1,189E-14	2,896E-15
27	0,00000	ENVELOPE_ ULS	Combination	Max	-1085,442	119,305	1,464E-14	2,896E-15
27	0,50047	ENVELOPE_ ULS	Combination	Max	-1081,795	108,091	1,327E-14	2,896E-15
27	1,00094	ENVELOPE_ ULS	Combination	Max	-1078,147	96,876	1,189E-14	2,896E-15
27	0,00000	ENVELOPE_ ULS	Combination	Min	-1400,581	20,547	-4,220E-14	-3,974E-14
27	0,50047	ENVELOPE_ ULS	Combination	Min	-1396,933	56,027	-4,358E-14	-3,974E-14
27	1,00094	ENVELOPE_ ULS	Combination	Min	-1393,286	90,806	-4,495E-14	-3,974E-14
28	0,00000	USL1	Combination		-1457,248	-88,577	-5,231E-14	-1,694E-14
28	0,50102	USL1	Combination		-1451,346	-53,685	-5,356E-14	-1,694E-14
28	1,00204	USL1	Combination		-1445,445	-19,945	-5,481E-14	-1,694E-14
28	0,00000	ULS2	Combination		-1181,417	36,790	4,537E-15	2,597E-15
28	0,50102	ULS2	Combination		-1175,516	26,566	3,284E-15	2,597E-15
28	1,00204	ULS2	Combination		-1169,614	16,341	2,032E-15	2,597E-15
28	0,00000	ENVELOPE_ ULS	Combination	Max	-1181,417	36,790	4,537E-15	2,597E-15
28	0,50102	ENVELOPE_ ULS	Combination	Max	-1175,516	26,566	3,284E-15	2,597E-15
28	1,00204	ENVELOPE_ ULS	Combination	Max	-1169,614	16,341	2,032E-15	2,597E-15

Table: Element Forces - Frames, Part 1 of 2

Frame	Station m	OutputCase	CaseType	StepType	P KN	V2 KN	V3 KN	T KN-m
28	0,00000	ENVELOPE_	Combination	Min	-1457,248	-88,577	-5,231E-14	-1,694E-14
		ULS						
28	0,50102	ENVELOPE_	Combination	Min	-1451,346	-53,685	-5,356E-14	-1,694E-14
		ULS						
28	1,00204	ENVELOPE_	Combination	Min	-1445,445	-19,945	-5,481E-14	-1,694E-14
		ULS						
29	0,00000	USL1	Combination		-1501,456	-232,095	-1,127E-14	-1,026E-14
29	0,50160	USL1	Combination		-1493,550	-198,170	-1,235E-14	-1,026E-14
29	1,00321	USL1	Combination		-1485,644	-165,699	-1,342E-14	-1,026E-14
29	0,00000	ULS2	Combination		-1281,493	-92,280	-1,127E-14	2,177E-15
29	0,50160	ULS2	Combination		-1273,587	-101,066	-1,235E-14	2,177E-15
29	1,00321	ULS2	Combination		-1265,681	-109,851	-1,342E-14	2,177E-15
29	0,00000	ENVELOPE_	Combination	Max	-1281,493	-92,280	-1,127E-14	2,177E-15
		ULS						
29	0,50160	ENVELOPE_	Combination	Max	-1273,587	-101,066	-1,235E-14	2,177E-15
		ULS						
29	1,00321	ENVELOPE_	Combination	Max	-1265,681	-109,851	-1,342E-14	2,177E-15
		ULS						
29	0,00000	ENVELOPE_	Combination	Min	-1501,456	-232,095	-1,127E-14	-1,026E-14
		ULS						
29	0,50160	ENVELOPE_	Combination	Min	-1493,550	-198,170	-1,235E-14	-1,026E-14
		ULS						
29	1,00321	ENVELOPE_	Combination	Min	-1485,644	-165,699	-1,342E-14	-1,026E-14
		ULS						
30	0,00000	USL1	Combination		-174,136	35,440	-5,158E-14	-3,516E-14
30	0,38282	USL1	Combination		-174,136	59,155	-5,246E-14	-3,516E-14
30	0,76564	USL1	Combination		-174,136	82,871	-5,335E-14	-3,516E-14
30	0,00000	ULS2	Combination		-40,020	38,055	5,264E-15	3,634E-16
30	0,38282	ULS2	Combination		-40,020	30,839	4,381E-15	3,634E-16
30	0,76564	ULS2	Combination		-40,020	23,622	3,497E-15	3,634E-16
30	0,00000	ENVELOPE_	Combination	Max	-40,020	38,055	5,264E-15	3,634E-16
		ULS						
30	0,38282	ENVELOPE_	Combination	Max	-40,020	59,155	4,381E-15	3,634E-16
		ULS						
30	0,76564	ENVELOPE_	Combination	Max	-40,020	82,871	3,497E-15	3,634E-16
		ULS						
30	0,00000	ENVELOPE_	Combination	Min	-174,136	35,440	-5,158E-14	-3,516E-14
		ULS						
30	0,38282	ENVELOPE_	Combination	Min	-174,136	30,839	-5,246E-14	-3,516E-14
		ULS						
30	0,76564	ENVELOPE_	Combination	Min	-174,136	23,622	-5,335E-14	-3,516E-14
		ULS						
31	0,00000	USL1	Combination		-183,636	82,871	3,497E-15	-3,161E-14
31	0,38282	USL1	Combination		-183,636	106,586	2,613E-15	-3,161E-14
31	0,76564	USL1	Combination		-183,636	130,302	1,729E-15	-3,161E-14
31	0,00000	ULS2	Combination		-49,520	23,622	3,497E-15	3,634E-16
31	0,38282	ULS2	Combination		-49,520	16,406	2,613E-15	3,634E-16
31	0,76564	ULS2	Combination		-49,520	9,189	1,729E-15	3,634E-16
31	0,00000	ENVELOPE_	Combination	Max	-49,520	82,871	3,497E-15	3,634E-16
		ULS						
31	0,38282	ENVELOPE_	Combination	Max	-49,520	106,586	2,613E-15	3,634E-16
		ULS						
31	0,76564	ENVELOPE_	Combination	Max	-49,520	130,302	1,729E-15	3,634E-16
		ULS						
31	0,00000	ENVELOPE_	Combination	Min	-183,636	23,622	3,497E-15	-3,161E-14
		ULS						
31	0,38282	ENVELOPE_	Combination	Min	-183,636	16,406	2,613E-15	-3,161E-14
		ULS						
31	0,76564	ENVELOPE_	Combination	Min	-183,636	9,189	1,729E-15	-3,161E-14
		ULS						
32	0,00000	USL1	Combination		-233,289	-193,136	-3,505E-14	2,721E-14
32	0,47625	USL1	Combination		-224,312	-155,667	-3,505E-14	2,721E-14
32	0,95249	USL1	Combination		-215,334	-120,223	-3,505E-14	2,721E-14

Table: Element Forces - Frames, Part 1 of 2

Frame	Station m	OutputCase	CaseType	StepType	P KN	V2 KN	V3 KN	T KN-m
32	0,00000	ULS2	Combination		-177,070	-59,020	-6,624E-15	1,164E-16
32	0,47625	ULS2	Combination		-168,092	-59,020	-6,624E-15	1,164E-16
32	0,95249	ULS2	Combination		-159,115	-59,020	-6,624E-15	1,164E-16
32	0,00000	ENVELOPE_ ULS	Combination	Max	-177,070	-59,020	-6,624E-15	2,721E-14
32	0,47625	ENVELOPE_ ULS	Combination	Max	-168,092	-59,020	-6,624E-15	2,721E-14
32	0,95249	ENVELOPE_ ULS	Combination	Max	-159,115	-59,020	-6,624E-15	2,721E-14
32	0,00000	ENVELOPE_ ULS	Combination	Min	-233,289	-193,136	-3,505E-14	1,164E-16
32	0,47625	ENVELOPE_ ULS	Combination	Min	-224,312	-155,667	-3,505E-14	1,164E-16
32	0,95249	ENVELOPE_ ULS	Combination	Min	-215,334	-120,223	-3,505E-14	1,164E-16
34	0,00000	USL1	Combination		-1103,149	-595,517	-6,516E-14	9,209E-14
34	0,47625	USL1	Combination		-1085,194	-566,156	-6,516E-14	9,209E-14
34	0,95249	USL1	Combination		-1067,239	-538,844	-6,516E-14	9,209E-14
34	0,00000	ULS2	Combination		-1002,687	-532,343	-6,516E-14	-2,851E-16
34	0,47625	ULS2	Combination		-984,732	-532,343	-6,516E-14	-2,851E-16
34	0,95249	ULS2	Combination		-966,777	-532,343	-6,516E-14	-2,851E-16
34	0,00000	ENVELOPE_ ULS	Combination	Max	-1002,687	-532,343	-6,516E-14	9,209E-14
34	0,47625	ENVELOPE_ ULS	Combination	Max	-984,732	-532,343	-6,516E-14	9,209E-14
34	0,95249	ENVELOPE_ ULS	Combination	Max	-966,777	-532,343	-6,516E-14	9,209E-14
34	0,00000	ENVELOPE_ ULS	Combination	Min	-1103,149	-595,517	-6,516E-14	-2,851E-16
34	0,47625	ENVELOPE_ ULS	Combination	Min	-1085,194	-566,156	-6,516E-14	-2,851E-16
34	0,95249	ENVELOPE_ ULS	Combination	Min	-1067,239	-538,844	-6,516E-14	-2,851E-16
35	0,00000	USL1	Combination		-1067,239	-39,872	2,441E-14	9,564E-14
35	0,47625	USL1	Combination		-1049,284	-14,595	2,441E-14	9,564E-14
35	0,95249	USL1	Combination		-1031,329	8,658	2,441E-14	9,564E-14
35	0,00000	ULS2	Combination		-966,777	-32,991	-4,009E-15	-2,851E-16
35	0,47625	ULS2	Combination		-948,822	-32,991	-4,009E-15	-2,851E-16
35	0,95249	ULS2	Combination		-930,867	-32,991	-4,009E-15	-2,851E-16
35	0,00000	ENVELOPE_ ULS	Combination	Max	-966,777	-32,991	2,441E-14	9,564E-14
35	0,47625	ENVELOPE_ ULS	Combination	Max	-948,822	-14,595	2,441E-14	9,564E-14
35	0,95249	ENVELOPE_ ULS	Combination	Max	-930,867	8,658	2,441E-14	9,564E-14
35	0,00000	ENVELOPE_ ULS	Combination	Min	-1067,239	-39,872	-4,009E-15	-2,851E-16
35	0,47625	ENVELOPE_ ULS	Combination	Min	-1049,284	-32,991	-4,009E-15	-2,851E-16
35	0,95249	ENVELOPE_ ULS	Combination	Min	-1031,329	-32,991	-4,009E-15	-2,851E-16
36	0,00000	USL1	Combination		-1031,329	480,161	1,106E-13	9,209E-14
36	0,47625	USL1	Combination		-1013,375	501,389	1,106E-13	9,209E-14
36	0,95249	USL1	Combination		-995,420	520,594	1,106E-13	9,209E-14
36	0,00000	ULS2	Combination		-930,867	438,723	5,376E-14	-2,851E-16
36	0,47625	ULS2	Combination		-912,912	438,723	5,376E-14	-2,851E-16
36	0,95249	ULS2	Combination		-894,957	438,723	5,376E-14	-2,851E-16
36	0,00000	ENVELOPE_ ULS	Combination	Max	-930,867	480,161	1,106E-13	9,209E-14
36	0,47625	ENVELOPE_ ULS	Combination	Max	-912,912	501,389	1,106E-13	9,209E-14
36	0,95249	ENVELOPE_ ULS	Combination	Max	-894,957	520,594	1,106E-13	9,209E-14

Table: Element Forces - Frames, Part 1 of 2

Frame	Station m	OutputCase	CaseType	StepType	P KN	V2 KN	V3 KN	T KN-m
36	0,00000	ENVELOPE_ ULS	Combination	Min	-1031,329	438,723	5,376E-14	-2,851E-16
36	0,47625	ENVELOPE_ ULS	Combination	Min	-1013,375	438,723	5,376E-14	-2,851E-16
36	0,95249	ENVELOPE_ ULS	Combination	Min	-995,420	438,723	5,376E-14	-2,851E-16
37	0,00000	USL1	Combination		-215,334	-129,723	1,059E-13	2,765E-14
37	0,23812	USL1	Combination		-210,845	-112,759	1,059E-13	2,765E-14
37	0,47625	USL1	Combination		-206,357	-96,302	1,059E-13	2,765E-14
37	0,00000	ULS2	Combination		-159,115	-68,520	-7,787E-15	1,164E-16
37	0,23812	ULS2	Combination		-154,626	-68,520	-7,787E-15	1,164E-16
37	0,47625	ULS2	Combination		-150,137	-68,520	-7,787E-15	1,164E-16
37	0,00000	ENVELOPE_ ULS	Combination	Max	-159,115	-68,520	1,059E-13	2,765E-14
37	0,23812	ENVELOPE_ ULS	Combination	Max	-154,626	-68,520	1,059E-13	2,765E-14
37	0,47625	ENVELOPE_ ULS	Combination	Max	-150,137	-68,520	1,059E-13	2,765E-14
37	0,00000	ENVELOPE_ ULS	Combination	Min	-215,334	-129,723	-7,787E-15	1,164E-16
37	0,23812	ENVELOPE_ ULS	Combination	Min	-210,845	-112,759	-7,787E-15	1,164E-16
37	0,47625	ENVELOPE_ ULS	Combination	Min	-206,357	-96,302	-7,787E-15	1,164E-16
38	0,00000	USL1	Combination		-1121,104	-1156,348	-1,300E-13	8,853E-14
38	0,23812	USL1	Combination		-1112,127	-1140,397	-1,300E-13	8,853E-14
38	0,47625	USL1	Combination		-1103,149	-1124,951	-1,300E-13	8,853E-14
38	0,00000	ULS2	Combination		-1020,642	-1061,817	-1,300E-13	-2,851E-16
38	0,23812	ULS2	Combination		-1011,664	-1061,817	-1,300E-13	-2,851E-16
38	0,47625	ULS2	Combination		-1002,687	-1061,817	-1,300E-13	-2,851E-16
38	0,00000	ENVELOPE_ ULS	Combination	Max	-1020,642	-1061,817	-1,300E-13	8,853E-14
38	0,23812	ENVELOPE_ ULS	Combination	Max	-1011,664	-1061,817	-1,300E-13	8,853E-14
38	0,47625	ENVELOPE_ ULS	Combination	Max	-1002,687	-1061,817	-1,300E-13	8,853E-14
38	0,00000	ENVELOPE_ ULS	Combination	Min	-1121,104	-1156,348	-1,300E-13	-2,851E-16
38	0,23812	ENVELOPE_ ULS	Combination	Min	-1112,127	-1140,397	-1,300E-13	-2,851E-16
38	0,47625	ENVELOPE_ ULS	Combination	Min	-1103,149	-1124,951	-1,300E-13	-2,851E-16
39	0,00000	USL1	Combination		-1419,096	-18,989	5,822E-15	-7,722E-15
39	1,04715	USL1	Combination		-1405,630	-33,421	4,054E-15	-7,722E-15
39	2,09431	USL1	Combination		-1392,164	-47,854	2,287E-15	-7,722E-15
39	0,00000	ULS2	Combination		-1340,109	-5,801	-1,283E-15	1,160E-15
39	1,04715	ULS2	Combination		-1326,643	-20,234	-3,051E-15	1,160E-15
39	2,09431	ULS2	Combination		-1313,177	-34,667	-4,818E-15	1,160E-15
39	0,00000	ENVELOPE_ ULS	Combination	Max	-1340,109	-5,801	5,822E-15	1,160E-15
39	1,04715	ENVELOPE_ ULS	Combination	Max	-1326,643	-20,234	4,054E-15	1,160E-15
39	2,09431	ENVELOPE_ ULS	Combination	Max	-1313,177	-34,667	2,287E-15	1,160E-15
39	0,00000	ENVELOPE_ ULS	Combination	Min	-1419,096	-18,989	-1,283E-15	-7,722E-15
39	1,04715	ENVELOPE_ ULS	Combination	Min	-1405,630	-33,421	-3,051E-15	-7,722E-15
39	2,09431	ENVELOPE_ ULS	Combination	Min	-1392,164	-47,854	-4,818E-15	-7,722E-15
40	0,00000	USL1	Combination		-809,820	175,186	4,478E-14	2,208E-14
40	1,03322	USL1	Combination		-796,353	161,114	4,305E-14	2,208E-14
40	2,06644	USL1	Combination		-782,887	147,043	4,133E-14	2,208E-14

Table: Element Forces - Frames, Part 1 of 2

Frame	Station m	OutputCase	CaseType	StepType	P KN	V2 KN	V3 KN	T KN-m
40	0,00000	ULS2	Combination		-730,518	189,784	2,524E-14	2,097E-15
40	1,03322	ULS2	Combination		-717,052	175,713	2,351E-14	2,097E-15
40	2,06644	ULS2	Combination		-703,586	161,641	2,179E-14	2,097E-15
40	0,00000	ENVELOPE_ ULS	Combination	Max	-730,518	189,784	4,478E-14	2,208E-14
40	1,03322	ENVELOPE_ ULS	Combination	Max	-717,052	175,713	4,305E-14	2,208E-14
40	2,06644	ENVELOPE_ ULS	Combination	Max	-703,586	161,641	4,133E-14	2,208E-14
40	0,00000	ENVELOPE_ ULS	Combination	Min	-809,820	175,186	2,524E-14	2,097E-15
40	1,03322	ENVELOPE_ ULS	Combination	Min	-796,353	161,114	2,351E-14	2,097E-15
40	2,06644	ENVELOPE_ ULS	Combination	Min	-782,887	147,043	2,179E-14	2,097E-15

Table: Element Forces - Frames, Part 2 of 2

Table: Element Forces - Frames, Part 2 of 2

Frame	Station m	OutputCase	StepType	M2 KN-m	M3 KN-m	FrameElem	ElemStation m
1	0,00000	USL1		-3,943E-14	-157,3147	1-1	0,00000
1	0,23812	USL1		-3,944E-14	-213,1161	1-1	0,23812
1	0,47625	USL1		-3,945E-14	-278,7371	1-1	0,47625
1	0,00000	ULS2		3,202E-15	-336,5321	1-1	0,00000
1	0,23812	ULS2		3,195E-15	-375,5098	1-1	0,23812
1	0,47625	ULS2		3,187E-15	-420,5688	1-1	0,47625
1	0,00000	ENVELOPE_ ULS	Max	3,202E-15	-157,3147	1-1	0,00000
1	0,23812	ENVELOPE_ ULS	Max	3,195E-15	-213,1161	1-1	0,23812
1	0,47625	ENVELOPE_ ULS	Max	3,187E-15	-278,7371	1-1	0,47625
1	0,00000	ENVELOPE_ ULS	Min	-3,943E-14	-336,5321	1-1	0,00000
1	0,23812	ENVELOPE_ ULS	Min	-3,944E-14	-375,5098	1-1	0,23812
1	0,47625	ENVELOPE_ ULS	Min	-3,945E-14	-420,5688	1-1	0,47625
2	0,00000	USL1		-8,739E-14	679,8491	2-1	0,00000
2	0,57862	USL1		-8,741E-14	669,7761	2-1	0,57862
2	1,15723	USL1		-8,743E-14	602,0602	2-1	1,15723
2	0,00000	ULS2		-2,125E-15	545,4095	2-1	0,00000
2	0,57862	ULS2		-2,143E-15	534,0958	2-1	0,57862
2	1,15723	ULS2		-2,161E-15	476,7232	2-1	1,15723
2	0,00000	ENVELOPE_ ULS	Max	-2,125E-15	679,8491	2-1	0,00000
2	0,57862	ENVELOPE_ ULS	Max	-2,143E-15	669,7761	2-1	0,57862
2	1,15723	ENVELOPE_ ULS	Max	-2,161E-15	602,0602	2-1	1,15723
2	0,00000	ENVELOPE_ ULS	Min	-8,739E-14	545,4095	2-1	0,00000
2	0,57862	ENVELOPE_ ULS	Min	-8,741E-14	534,0958	2-1	0,57862
2	1,15723	ENVELOPE_ ULS	Min	-8,743E-14	476,7232	2-1	1,15723
3	0,00000	USL1		-2,011E-13	602,0602	3-1	0,00000
3	0,51232	USL1		-1,720E-13	507,2995	3-1	0,51232
3	1,02464	USL1		-1,429E-13	373,1784	3-1	1,02464
3	0,00000	ULS2		-2,161E-15	476,7232	3-1	0,00000

Table: Element Forces - Frames, Part 2 of 2

Frame	Station m	OutputCase	StepType	M2 KN-m	M3 KN-m	FrameElem	ElemStation m
3	0,51232	ULS2		-2,177E-15	399,8194	3-1	0,51232
3	1,02464	ULS2		-2,193E-15	290,8387	3-1	1,02464
3	0,00000	ENVELOPE_ ULS	Max	-2,161E-15	602,0602	3-1	0,00000
3	0,51232	ENVELOPE_ ULS	Max	-2,177E-15	507,2995	3-1	0,51232
3	1,02464	ENVELOPE_ ULS	Max	-2,193E-15	373,1784	3-1	1,02464
3	0,00000	ENVELOPE_ ULS	Min	-2,011E-13	476,7232	3-1	0,00000
3	0,51232	ENVELOPE_ ULS	Min	-1,720E-13	399,8194	3-1	0,51232
3	1,02464	ENVELOPE_ ULS	Min	-1,429E-13	290,8387	3-1	1,02464
4	0,00000	USL1		-1,726E-13	373,1784	4-1	0,00000
4	0,49473	USL1		-1,867E-13	243,7182	4-1	0,49473
4	0,98945	USL1		-2,008E-13	82,9401	4-1	0,98945
4	0,00000	ULS2		-2,071E-15	290,8387	4-1	0,00000
4	0,49473	ULS2		-2,086E-15	188,7221	4-1	0,49473
4	0,98945	ULS2		-2,102E-15	60,5620	4-1	0,98945
4	0,00000	ENVELOPE_ ULS	Max	-2,071E-15	373,1784	4-1	0,00000
4	0,49473	ENVELOPE_ ULS	Max	-2,086E-15	243,7182	4-1	0,49473
4	0,98945	ENVELOPE_ ULS	Max	-2,102E-15	82,9401	4-1	0,98945
4	0,00000	ENVELOPE_ ULS	Min	-1,726E-13	290,8387	4-1	0,00000
4	0,49473	ENVELOPE_ ULS	Min	-1,867E-13	188,7221	4-1	0,49473
4	0,98945	ENVELOPE_ ULS	Min	-2,008E-13	60,5620	4-1	0,98945
5	0,00000	USL1		-1,721E-13	82,9401	5-1	0,00000
5	0,49402	USL1		-2,002E-13	-2,2620	5-1	0,49402
5	0,98804	USL1		-2,283E-13	-115,9396	5-1	0,98804
5	0,00000	ULS2		-1,540E-15	60,5620	5-1	0,00000
5	0,49402	ULS2		-1,555E-15	-1,0684	5-1	0,49402
5	0,98804	ULS2		-1,570E-15	-87,1961	5-1	0,98804
5	0,00000	ENVELOPE_ ULS	Max	-1,540E-15	82,9401	5-1	0,00000
5	0,49402	ENVELOPE_ ULS	Max	-1,555E-15	-1,0684	5-1	0,49402
5	0,98804	ENVELOPE_ ULS	Max	-1,570E-15	-87,1961	5-1	0,98804
5	0,00000	ENVELOPE_ ULS	Min	-1,721E-13	60,5620	5-1	0,00000
5	0,49402	ENVELOPE_ ULS	Min	-2,002E-13	-2,2620	5-1	0,49402
5	0,98804	ENVELOPE_ ULS	Min	-2,283E-13	-115,9396	5-1	0,98804
6	0,00000	USL1		-1,714E-13	-115,9396	6-1	0,00000
6	0,49382	USL1		-1,434E-13	-153,0140	6-1	0,49382
6	0,98763	USL1		-1,153E-13	-216,1279	6-1	0,98763
6	0,00000	ULS2		-9,100E-16	-87,1961	6-1	0,00000
6	0,49382	ULS2		-9,254E-16	-108,7021	6-1	0,49382
6	0,98763	ULS2		-9,407E-16	-153,1872	6-1	0,98763
6	0,00000	ENVELOPE_ ULS	Max	-9,100E-16	-87,1961	6-1	0,00000
6	0,49382	ENVELOPE_ ULS	Max	-9,254E-16	-108,7021	6-1	0,49382
6	0,98763	ENVELOPE_ ULS	Max	-9,407E-16	-153,1872	6-1	0,98763

Table: Element Forces - Frames, Part 2 of 2

Frame	Station m	OutputCase	StepType	M2 KN-m	M3 KN-m	FrameElem	ElemStation m
6	0,00000	ENVELOPE_ ULS	Min	-1,714E-13	-115,9396	6-1	0,00000
6	0,49382	ENVELOPE_ ULS	Min	-1,434E-13	-153,0140	6-1	0,49382
6	0,98763	ENVELOPE_ ULS	Min	-1,153E-13	-216,1279	6-1	0,98763
7	0,00000	USL1		-8,548E-14	-216,1279	7-1	0,00000
7	0,52308	USL1		3,702E-15	-204,2409	7-1	0,52308
7	1,04617	USL1		9,289E-14	-218,9654	7-1	1,04617
7	0,00000	ULS2		-2,185E-16	-153,1872	7-1	0,00000
7	0,52308	ULS2		-2,347E-16	-136,2182	7-1	0,52308
7	1,04617	ULS2		-2,509E-16	-142,9740	7-1	1,04617
7	0,00000	ENVELOPE_ ULS	Max	-2,185E-16	-153,1872	7-1	0,00000
7	0,52308	ENVELOPE_ ULS	Max	3,702E-15	-136,2182	7-1	0,52308
7	1,04617	ENVELOPE_ ULS	Max	9,289E-14	-142,9740	7-1	1,04617
7	0,00000	ENVELOPE_ ULS	Min	-8,548E-14	-216,1279	7-1	0,00000
7	0,52308	ENVELOPE_ ULS	Min	-2,347E-16	-204,2409	7-1	0,52308
7	1,04617	ENVELOPE_ ULS	Min	-2,509E-16	-218,9654	7-1	1,04617
8	0,00000	USL1		5,166E-16	-218,9654	8-1	0,00000
8	0,54165	USL1		3,129E-14	-156,5312	8-1	0,54165
8	1,08329	USL1		6,206E-14	-124,3620	8-1	1,08329
8	0,00000	ULS2		5,166E-16	-142,9740	8-1	0,00000
8	0,54165	ULS2		4,998E-16	-88,8064	8-1	0,54165
8	1,08329	ULS2		4,830E-16	-61,8086	8-1	1,08329
8	0,00000	ENVELOPE_ ULS	Max	5,166E-16	-142,9740	8-1	0,00000
8	0,54165	ENVELOPE_ ULS	Max	3,129E-14	-88,8064	8-1	0,54165
8	1,08329	ENVELOPE_ ULS	Max	6,206E-14	-61,8086	8-1	1,08329
8	0,00000	ENVELOPE_ ULS	Min	5,166E-16	-218,9654	8-1	0,00000
8	0,54165	ENVELOPE_ ULS	Min	4,998E-16	-156,5312	8-1	0,54165
8	1,08329	ENVELOPE_ ULS	Min	4,830E-16	-124,3620	8-1	1,08329
9	0,00000	USL1		5,805E-14	-124,3620	9-1	0,00000
9	0,49252	USL1		5,803E-14	-42,8323	9-1	0,49252
9	0,98504	USL1		5,802E-14	8,5679	9-1	0,98504
9	0,00000	ULS2		1,204E-15	-61,8086	9-1	0,00000
9	0,49252	ULS2		1,189E-15	0,9911	9-1	0,49252
9	0,98504	ULS2		1,174E-15	36,7056	9-1	0,98504
9	0,00000	ENVELOPE_ ULS	Max	5,805E-14	-61,8086	9-1	0,00000
9	0,49252	ENVELOPE_ ULS	Max	5,803E-14	0,9911	9-1	0,49252
9	0,98504	ENVELOPE_ ULS	Max	5,802E-14	36,7056	9-1	0,98504
9	0,00000	ENVELOPE_ ULS	Min	1,204E-15	-124,3620	9-1	0,00000
9	0,49252	ENVELOPE_ ULS	Min	1,189E-15	-42,8323	9-1	0,49252
9	0,98504	ENVELOPE_ ULS	Min	1,174E-15	8,5679	9-1	0,98504
10	0,00000	USL1		5,865E-14	8,5679	10-1	0,00000
10	0,49197	USL1		5,864E-14	93,8295	10-1	0,49197
10	0,98394	USL1		5,862E-14	143,7411	10-1	0,98394

Table: Element Forces - Frames, Part 2 of 2

Frame	Station m	OutputCase	StepType	M2 KN-m	M3 KN-m	FrameElem	ElemStation m
10	0,00000	ULS2		1,807E-15	36,7056	10-1	0,00000
10	0,49197	ULS2		1,792E-15	94,4267	10-1	0,49197
10	0,98394	ULS2		1,777E-15	120,7429	10-1	0,98394
10	0,00000	ENVELOPE_ ULS	Max	5,865E-14	36,7056	10-1	0,00000
10	0,49197	ENVELOPE_ ULS	Max	5,864E-14	94,4267	10-1	0,49197
10	0,98394	ENVELOPE_ ULS	Max	5,862E-14	143,7411	10-1	0,98394
10	0,00000	ENVELOPE_ ULS	Min	1,807E-15	8,5679	10-1	0,00000
10	0,49197	ENVELOPE_ ULS	Min	1,792E-15	93,8295	10-1	0,49197
10	0,98394	ENVELOPE_ ULS	Min	1,777E-15	120,7429	10-1	0,98394
11	0,00000	USL1		3,072E-14	143,7411	11-1	0,00000
11	0,49208	USL1		5,868E-14	211,0488	11-1	0,49208
11	0,98416	USL1		8,663E-14	237,2065	11-1	0,98416
11	0,00000	ULS2		2,298E-15	120,7429	11-1	0,00000
11	0,49208	ULS2		2,283E-15	155,6689	11-1	0,49208
11	0,98416	ULS2		2,268E-15	154,6630	11-1	0,98416
11	0,00000	ENVELOPE_ ULS	Max	3,072E-14	143,7411	11-1	0,00000
11	0,49208	ENVELOPE_ ULS	Max	5,868E-14	211,0488	11-1	0,49208
11	0,98416	ENVELOPE_ ULS	Max	8,663E-14	237,2065	11-1	0,98416
11	0,00000	ENVELOPE_ ULS	Min	2,298E-15	120,7429	11-1	0,00000
11	0,49208	ENVELOPE_ ULS	Min	2,283E-15	155,6689	11-1	0,49208
11	0,98416	ENVELOPE_ ULS	Min	2,268E-15	154,6630	11-1	0,98416
12	0,00000	USL1		8,764E-14	237,2065	12-1	0,00000
12	0,50938	USL1		8,762E-14	222,1389	12-1	0,50938
12	1,01876	USL1		8,761E-14	155,5197	12-1	1,01876
12	0,00000	ULS2		2,372E-15	154,6630	12-1	0,00000
12	0,50938	ULS2		2,356E-15	114,8637	12-1	0,50938
12	1,01876	ULS2		2,340E-15	30,7132	12-1	1,01876
12	0,00000	ENVELOPE_ ULS	Max	8,764E-14	237,2065	12-1	0,00000
12	0,50938	ENVELOPE_ ULS	Max	8,762E-14	222,1389	12-1	0,50938
12	1,01876	ENVELOPE_ ULS	Max	8,761E-14	155,5197	12-1	1,01876
12	0,00000	ENVELOPE_ ULS	Min	2,372E-15	154,6630	12-1	0,00000
12	0,50938	ENVELOPE_ ULS	Min	2,356E-15	114,8637	12-1	0,50938
12	1,01876	ENVELOPE_ ULS	Min	2,340E-15	30,7132	12-1	1,01876
13	0,00000	USL1		1,160E-13	155,5197	13-1	0,00000
13	0,56894	USL1		1,160E-13	4,4572	13-1	0,56894
13	1,13787	USL1		1,160E-13	-219,6735	13-1	1,13787
13	0,00000	ULS2		2,340E-15	30,7132	13-1	0,00000
13	0,56894	ULS2		2,322E-15	-130,3840	13-1	0,56894
13	1,13787	ULS2		2,305E-15	-353,3498	13-1	1,13787
13	0,00000	ENVELOPE_ ULS	Max	1,160E-13	155,5197	13-1	0,00000
13	0,56894	ENVELOPE_ ULS	Max	1,160E-13	4,4572	13-1	0,56894
13	1,13787	ENVELOPE_ ULS	Max	1,160E-13	-219,6735	13-1	1,13787

Table: Element Forces - Frames, Part 2 of 2

Frame	Station m	OutputCase	StepType	M2 KN-m	M3 KN-m	FrameElem	ElemStation m
13	0,00000	ENVELOPE_ ULS	Min	2,340E-15	30,7132	13-1	0,00000
13	0,56894	ENVELOPE_ ULS	Min	2,322E-15	-130,3840	13-1	0,56894
13	1,13787	ENVELOPE_ ULS	Min	2,305E-15	-353,3498	13-1	1,13787
14	0,00000	USL1		8,856E-14	-219,6735	14-1	0,00000
14	0,47625	USL1		8,854E-14	-126,7616	14-1	0,47625
14	0,95249	USL1		8,853E-14	-62,4618	14-1	0,95249
14	0,00000	ULS2		3,291E-15	-353,3498	14-1	0,00000
14	0,47625	ULS2		3,276E-15	-295,3140	14-1	0,47625
14	0,95249	ULS2		3,261E-15	-256,2622	14-1	0,95249
14	0,00000	ENVELOPE_ ULS	Max	8,856E-14	-219,6735	14-1	0,00000
14	0,47625	ENVELOPE_ ULS	Max	8,854E-14	-126,7616	14-1	0,47625
14	0,95249	ENVELOPE_ ULS	Max	8,853E-14	-62,4618	14-1	0,95249
14	0,00000	ENVELOPE_ ULS	Min	3,291E-15	-353,3498	14-1	0,00000
14	0,47625	ENVELOPE_ ULS	Min	3,276E-15	-295,3140	14-1	0,47625
14	0,95249	ENVELOPE_ ULS	Min	3,261E-15	-256,2622	14-1	0,95249
15	0,00000	USL1		6,010E-14	-62,4618	15-1	0,00000
15	0,47625	USL1		5,947E-15	-33,2377	15-1	0,47625
15	0,95249	USL1		-4,821E-14	-36,5042	15-1	0,95249
15	0,00000	ULS2		3,261E-15	-256,2622	15-1	0,00000
15	0,47625	ULS2		3,246E-15	-241,6941	15-1	0,47625
15	0,95249	ULS2		3,232E-15	-248,0606	15-1	0,95249
15	0,00000	ENVELOPE_ ULS	Max	6,010E-14	-62,4618	15-1	0,00000
15	0,47625	ENVELOPE_ ULS	Max	5,947E-15	-33,2377	15-1	0,47625
15	0,95249	ENVELOPE_ ULS	Max	3,232E-15	-36,5042	15-1	0,95249
15	0,00000	ENVELOPE_ ULS	Min	3,261E-15	-256,2622	15-1	0,00000
15	0,47625	ENVELOPE_ ULS	Min	3,246E-15	-241,6941	15-1	0,47625
15	0,95249	ENVELOPE_ ULS	Min	-4,821E-14	-248,0606	15-1	0,95249
16	0,00000	USL1		-2,519E-14	-36,5042	16-1	0,00000
16	0,47625	USL1		-2,520E-14	-78,7249	16-1	0,47625
16	0,95249	USL1		-2,522E-14	-157,3147	16-1	0,95249
16	0,00000	ULS2		3,232E-15	-248,0606	16-1	0,00000
16	0,47625	ULS2		3,217E-15	-280,8595	16-1	0,47625
16	0,95249	ULS2		3,202E-15	-336,5321	16-1	0,95249
16	0,00000	ENVELOPE_ ULS	Max	3,232E-15	-36,5042	16-1	0,00000
16	0,47625	ENVELOPE_ ULS	Max	3,217E-15	-78,7249	16-1	0,47625
16	0,95249	ENVELOPE_ ULS	Max	3,202E-15	-157,3147	16-1	0,95249
16	0,00000	ENVELOPE_ ULS	Min	-2,519E-14	-248,0606	16-1	0,00000
16	0,47625	ENVELOPE_ ULS	Min	-2,520E-14	-280,8595	16-1	0,47625
16	0,95249	ENVELOPE_ ULS	Min	-2,522E-14	-336,5321	16-1	0,95249
18	0,00000	USL1		-4,401E-16	-56,2967	18-1	0,00000
18	0,47625	USL1		-2,319E-14	-48,2492	18-1	0,47625
18	0,95249	USL1		-4,594E-14	-84,3277	18-1	0,95249

Table: Element Forces - Frames, Part 2 of 2

Frame	Station m	OutputCase	StepType	M2 KN-m	M3 KN-m	FrameElem	ElemStation m
18	0,00000	ULS2		-4,401E-16	-116,2901	18-1	0,00000
18	0,47625	ULS2		4,959E-16	-71,1164	18-1	0,47625
18	0,95249	ULS2		1,432E-15	-52,7065	18-1	0,95249
18	0,00000	ENVELOPE_ ULS	Max	-4,401E-16	-56,2967	18-1	0,00000
18	0,47625	ENVELOPE_ ULS	Max	4,959E-16	-48,2492	18-1	0,47625
18	0,95249	ENVELOPE_ ULS	Max	1,432E-15	-52,7065	18-1	0,95249
18	0,00000	ENVELOPE_ ULS	Min	-4,401E-16	-116,2901	18-1	0,00000
18	0,47625	ENVELOPE_ ULS	Min	-2,319E-14	-71,1164	18-1	0,47625
18	0,95249	ENVELOPE_ ULS	Min	-4,594E-14	-84,3277	18-1	0,95249
19	0,00000	USL1		-7,211E-14	-84,3277	19-1	0,00000
19	0,38282	USL1		-6,133E-14	-6,8011	19-1	0,38282
19	0,76564	USL1		-5,022E-14	61,6467	19-1	0,76564
19	0,00000	ULS2		-8,159E-15	-52,7065	19-1	0,00000
19	0,38282	ULS2		-2,823E-15	-15,2791	19-1	0,38282
19	0,76564	ULS2		2,852E-15	24,9108	19-1	0,76564
19	0,00000	ENVELOPE_ ULS	Max	-8,159E-15	-52,7065	19-1	0,00000
19	0,38282	ENVELOPE_ ULS	Max	-2,823E-15	-6,8011	19-1	0,38282
19	0,76564	ENVELOPE_ ULS	Max	2,852E-15	61,6467	19-1	0,76564
19	0,00000	ENVELOPE_ ULS	Min	-7,211E-14	-84,3277	19-1	0,00000
19	0,38282	ENVELOPE_ ULS	Min	-6,133E-14	-15,2791	19-1	0,38282
19	0,76564	ENVELOPE_ ULS	Min	-5,022E-14	24,9108	19-1	0,76564
20	0,00000	USL1		-5,399E-14	61,6467	20-1	0,00000
20	0,36365	USL1		-6,896E-14	118,2587	20-1	0,36365
20	0,72730	USL1		-8,362E-14	166,6783	20-1	0,72730
20	0,00000	ULS2		2,852E-15	24,9108	20-1	0,00000
20	0,36365	ULS2		8,555E-15	65,6467	20-1	0,36365
20	0,72730	ULS2		1,456E-14	108,8753	20-1	0,72730
20	0,00000	ENVELOPE_ ULS	Max	2,852E-15	61,6467	20-1	0,00000
20	0,36365	ENVELOPE_ ULS	Max	8,555E-15	118,2587	20-1	0,36365
20	0,72730	ENVELOPE_ ULS	Max	1,456E-14	166,6783	20-1	0,72730
20	0,00000	ENVELOPE_ ULS	Min	-5,399E-14	24,9108	20-1	0,00000
20	0,36365	ENVELOPE_ ULS	Min	-6,896E-14	65,6467	20-1	0,36365
20	0,72730	ENVELOPE_ ULS	Min	-8,362E-14	108,8753	20-1	0,72730
21	0,00000	USL1		-1,529E-13	331,9293	21-1	0,00000
21	0,50061	USL1		-1,319E-13	352,3178	21-1	0,50061
21	1,00122	USL1		-1,129E-13	335,7411	21-1	1,00122
21	0,00000	ULS2		3,182E-14	243,1819	21-1	0,00000
21	0,50061	ULS2		3,859E-14	298,6027	21-1	0,50061
21	1,00122	ULS2		4,340E-14	338,0344	21-1	1,00122
21	0,00000	ENVELOPE_ ULS	Max	3,182E-14	331,9293	21-1	0,00000
21	0,50061	ENVELOPE_ ULS	Max	3,859E-14	352,3178	21-1	0,50061
21	1,00122	ENVELOPE_ ULS	Max	4,340E-14	338,0344	21-1	1,00122

Table: Element Forces - Frames, Part 2 of 2

Frame	Station m	OutputCase	StepType	M2 KN-m	M3 KN-m	FrameElem	ElemStation m
21	0,00000	ENVELOPE_ ULS	Min	-1,529E-13	243,1819	21-1	0,00000
21	0,50061	ENVELOPE_ ULS	Min	-1,319E-13	298,6027	21-1	0,50061
21	1,00122	ENVELOPE_ ULS	Min	-1,129E-13	335,7411	21-1	1,00122
22	0,00000	USL1		-1,560E-13	335,7411	22-1	0,00000
22	0,49901	USL1		-1,430E-13	297,0572	22-1	0,49901
22	0,99802	USL1		-1,313E-13	224,8605	22-1	0,99802
22	0,00000	ULS2		4,294E-14	338,0344	22-1	0,00000
22	0,49901	ULS2		4,180E-14	328,8056	22-1	0,49901
22	0,99802	ULS2		3,926E-14	308,2010	22-1	0,99802
22	0,00000	ENVELOPE_ ULS	Max	4,294E-14	338,0344	22-1	0,00000
22	0,49901	ENVELOPE_ ULS	Max	4,180E-14	328,8056	22-1	0,49901
22	0,99802	ENVELOPE_ ULS	Max	3,926E-14	308,2010	22-1	0,99802
22	0,00000	ENVELOPE_ ULS	Min	-1,560E-13	335,7411	22-1	0,00000
22	0,49901	ENVELOPE_ ULS	Min	-1,430E-13	297,0572	22-1	0,49901
22	0,99802	ENVELOPE_ ULS	Min	-1,313E-13	224,8605	22-1	0,99802
23	0,00000	USL1		-1,603E-13	224,8605	23-1	0,00000
23	0,49922	USL1		-1,816E-13	151,2457	23-1	0,49922
23	0,99844	USL1		-2,036E-13	49,5397	23-1	0,99844
23	0,00000	ULS2		3,866E-14	308,2010	23-1	0,00000
23	0,49922	ULS2		3,150E-14	249,8085	23-1	0,49922
23	0,99844	ULS2		2,372E-14	186,4025	23-1	0,99844
23	0,00000	ENVELOPE_ ULS	Max	3,866E-14	308,2010	23-1	0,00000
23	0,49922	ENVELOPE_ ULS	Max	3,150E-14	249,8085	23-1	0,49922
23	0,99844	ENVELOPE_ ULS	Max	2,372E-14	186,4025	23-1	0,99844
23	0,00000	ENVELOPE_ ULS	Min	-1,603E-13	224,8605	23-1	0,00000
23	0,49922	ENVELOPE_ ULS	Min	-1,816E-13	151,2457	23-1	0,49922
23	0,99844	ENVELOPE_ ULS	Min	-2,036E-13	49,5397	23-1	0,99844
24	0,00000	USL1		-1,190E-13	49,5397	24-1	0,00000
24	0,52170	USL1		-8,547E-14	-36,6945	24-1	0,52170
24	1,04339	USL1		-5,161E-14	-146,3274	24-1	1,04339
24	0,00000	ULS2		2,307E-14	186,4025	24-1	0,00000
24	0,52170	ULS2		1,216E-14	97,4532	24-1	0,52170
24	1,04339	ULS2		1,536E-15	10,8248	24-1	1,04339
24	0,00000	ENVELOPE_ ULS	Max	2,307E-14	186,4025	24-1	0,00000
24	0,52170	ENVELOPE_ ULS	Max	1,216E-14	97,4532	24-1	0,52170
24	1,04339	ENVELOPE_ ULS	Max	1,536E-15	10,8248	24-1	1,04339
24	0,00000	ENVELOPE_ ULS	Min	-1,190E-13	49,5397	24-1	0,00000
24	0,52170	ENVELOPE_ ULS	Min	-8,547E-14	-36,6945	24-1	0,52170
24	1,04339	ENVELOPE_ ULS	Min	-5,161E-14	-146,3274	24-1	1,04339
25	0,00000	USL1		-2,755E-14	-146,3274	25-1	0,00000
25	0,50307	USL1		-8,718E-15	-205,3529	25-1	0,50307
25	1,00615	USL1		1,084E-14	-282,3641	25-1	1,00615

Table: Element Forces - Frames, Part 2 of 2

Frame	Station m	OutputCase	StepType	M2 KN-m	M3 KN-m	FrameElem	ElemStation m
25	0,00000	ULS2		8,751E-16	10,8248	25-1	0,00000
25	0,50307	ULS2		-8,892E-15	-68,8049	25-1	0,50307
25	1,00615	ULS2		-1,793E-14	-142,5039	25-1	1,00615
25	0,00000	ENVELOPE_ ULS	Max	8,751E-16	10,8248	25-1	0,00000
25	0,50307	ENVELOPE_ ULS	Max	-8,718E-15	-68,8049	25-1	0,50307
25	1,00615	ENVELOPE_ ULS	Max	1,084E-14	-142,5039	25-1	1,00615
25	0,00000	ENVELOPE_ ULS	Min	-2,755E-14	-146,3274	25-1	0,00000
25	0,50307	ENVELOPE_ ULS	Min	-8,892E-15	-205,3529	25-1	0,50307
25	1,00615	ENVELOPE_ ULS	Min	-1,793E-14	-282,3641	25-1	1,00615
26	0,00000	USL1		3,415E-14	-111,0554	26-1	0,00000
26	0,23812	USL1		2,024E-14	-78,5239	26-1	0,23812
26	0,47625	USL1		6,324E-15	-56,2967	26-1	0,47625
26	0,00000	ULS2		-1,376E-15	-191,7764	26-1	0,00000
26	0,23812	ULS2		-9,081E-16	-150,8706	26-1	0,23812
26	0,47625	ULS2		-4,401E-16	-116,2901	26-1	0,47625
26	0,00000	ENVELOPE_ ULS	Max	3,415E-14	-111,0554	26-1	0,00000
26	0,23812	ENVELOPE_ ULS	Max	2,024E-14	-78,5239	26-1	0,23812
26	0,47625	ENVELOPE_ ULS	Max	6,324E-15	-56,2967	26-1	0,47625
26	0,00000	ENVELOPE_ ULS	Min	-1,376E-15	-191,7764	26-1	0,00000
26	0,23812	ENVELOPE_ ULS	Min	-9,081E-16	-150,8706	26-1	0,23812
26	0,47625	ENVELOPE_ ULS	Min	-4,401E-16	-116,2901	26-1	0,47625
27	0,00000	USL1		3,828E-14	-282,3641	27-1	0,00000
27	0,50047	USL1		5,975E-14	-301,5548	27-1	0,50047
27	1,00094	USL1		8,190E-14	-338,3267	27-1	1,00094
27	0,00000	ULS2		-1,856E-14	-142,5039	27-1	0,00000
27	0,50047	ULS2		-2,554E-14	-199,4063	27-1	0,50047
27	1,00094	ULS2		-3,184E-14	-250,6963	27-1	1,00094
27	0,00000	ENVELOPE_ ULS	Max	3,828E-14	-142,5039	27-1	0,00000
27	0,50047	ENVELOPE_ ULS	Max	5,975E-14	-199,4063	27-1	0,50047
27	1,00094	ENVELOPE_ ULS	Max	8,190E-14	-250,6963	27-1	1,00094
27	0,00000	ENVELOPE_ ULS	Min	-1,856E-14	-282,3641	27-1	0,00000
27	0,50047	ENVELOPE_ ULS	Min	-2,554E-14	-301,5548	27-1	0,50047
27	1,00094	ENVELOPE_ ULS	Min	-3,184E-14	-338,3267	27-1	1,00094
28	0,00000	USL1		8,127E-14	-338,3267	28-1	0,00000
28	0,50102	USL1		1,078E-13	-302,7366	28-1	0,50102
28	1,00204	USL1		1,349E-13	-284,3396	28-1	1,00204
28	0,00000	ULS2		-3,242E-14	-250,6963	28-1	0,00000
28	0,50102	ULS2		-3,438E-14	-266,5676	28-1	0,50102
28	1,00204	ULS2		-3,571E-14	-277,3161	28-1	1,00204
28	0,00000	ENVELOPE_ ULS	Max	8,127E-14	-250,6963	28-1	0,00000
28	0,50102	ENVELOPE_ ULS	Max	1,078E-13	-266,5676	28-1	0,50102
28	1,00204	ENVELOPE_ ULS	Max	1,349E-13	-277,3161	28-1	1,00204

Table: Element Forces - Frames, Part 2 of 2

Frame	Station m	OutputCase	StepType	M2 KN-m	M3 KN-m	FrameElem	ElemStation m
28	0,00000	ENVELOPE_ ULS	Min	-3,242E-14	-338,3267	28-1	0,00000
28	0,50102	ENVELOPE_ ULS	Min	-3,438E-14	-302,7366	28-1	0,50102
28	1,00204	ENVELOPE_ ULS	Min	-3,571E-14	-284,3396	28-1	1,00204
29	0,00000	USL1		1,201E-13	-284,3396	29-1	0,00000
29	0,50160	USL1		1,260E-13	-176,4891	29-1	0,50160
29	1,00321	USL1		1,325E-13	-85,2910	29-1	1,00321
29	0,00000	ULS2		-3,621E-14	-277,3161	29-1	0,00000
29	0,50160	ULS2		-3,029E-14	-228,8247	29-1	0,50160
29	1,00321	ULS2		-2,382E-14	-175,9263	29-1	1,00321
29	0,00000	ENVELOPE_ ULS	Max	1,201E-13	-277,3161	29-1	0,00000
29	0,50160	ENVELOPE_ ULS	Max	1,260E-13	-176,4891	29-1	0,50160
29	1,00321	ENVELOPE_ ULS	Max	1,325E-13	-85,2910	29-1	1,00321
29	0,00000	ENVELOPE_ ULS	Min	-3,621E-14	-284,3396	29-1	0,00000
29	0,50160	ENVELOPE_ ULS	Min	-3,029E-14	-228,8247	29-1	0,50160
29	1,00321	ENVELOPE_ ULS	Min	-2,382E-14	-175,9263	29-1	1,00321
30	0,00000	USL1		3,614E-14	-3,2507	30-1	0,00000
30	0,38282	USL1		5,606E-14	-21,3571	30-1	0,38282
30	0,76564	USL1		7,631E-14	-48,5422	30-1	0,76564
30	0,00000	ULS2		-6,492E-15	-61,5156	30-1	0,00000
30	0,38282	ULS2		-8,338E-15	-74,7025	30-1	0,38282
30	0,76564	ULS2		-9,846E-15	-85,1268	30-1	0,76564
30	0,00000	ENVELOPE_ ULS	Max	3,614E-14	-3,2507	30-1	0,00000
30	0,38282	ENVELOPE_ ULS	Max	5,606E-14	-21,3571	30-1	0,38282
30	0,76564	ENVELOPE_ ULS	Max	7,631E-14	-48,5422	30-1	0,76564
30	0,00000	ENVELOPE_ ULS	Min	-6,492E-15	-61,5156	30-1	0,00000
30	0,38282	ENVELOPE_ ULS	Min	-8,338E-15	-74,7025	30-1	0,38282
30	0,76564	ENVELOPE_ ULS	Min	-9,846E-15	-85,1268	30-1	0,76564
31	0,00000	USL1		3,279E-14	-48,5422	31-1	0,00000
31	0,38282	USL1		3,162E-14	-84,8061	31-1	0,38282
31	0,76564	USL1		3,079E-14	-130,1488	31-1	0,76564
31	0,00000	ULS2		-9,846E-15	-85,1268	31-1	0,00000
31	0,38282	ULS2		-1,102E-14	-92,7885	31-1	0,38282
31	0,76564	ULS2		-1,185E-14	-97,6877	31-1	0,76564
31	0,00000	ENVELOPE_ ULS	Max	3,279E-14	-48,5422	31-1	0,00000
31	0,38282	ENVELOPE_ ULS	Max	3,162E-14	-84,8061	31-1	0,38282
31	0,76564	ENVELOPE_ ULS	Max	3,079E-14	-97,6877	31-1	0,76564
31	0,00000	ENVELOPE_ ULS	Min	-9,846E-15	-85,1268	31-1	0,00000
31	0,38282	ENVELOPE_ ULS	Min	-1,102E-14	-92,7885	31-1	0,38282
31	0,76564	ENVELOPE_ ULS	Min	-1,185E-14	-130,1488	31-1	0,76564
32	0,00000	USL1		3,031E-14	-130,1488	32-1	0,00000
32	0,47625	USL1		4,700E-14	-47,1710	32-1	0,47625
32	0,95249	USL1		6,369E-14	18,4444	32-1	0,95249

Table: Element Forces - Frames, Part 2 of 2

Frame	Station m	OutputCase	StepType	M2 KN-m	M3 KN-m	FrameElem	ElemStation m
32	0,00000	ULS2		-1,233E-14	-97,6877	32-1	0,00000
32	0,47625	ULS2		-9,172E-15	-69,5797	32-1	0,47625
32	0,95249	ULS2		-6,018E-15	-41,4717	32-1	0,95249
32	0,00000	ENVELOPE_ ULS	Max	3,031E-14	-97,6877	32-1	0,00000
32	0,47625	ENVELOPE_ ULS	Max	4,700E-14	-47,1710	32-1	0,47625
32	0,95249	ENVELOPE_ ULS	Max	6,369E-14	18,4444	32-1	0,95249
32	0,00000	ENVELOPE_ ULS	Min	-1,233E-14	-130,1488	32-1	0,00000
32	0,47625	ENVELOPE_ ULS	Min	-9,172E-15	-69,5797	32-1	0,47625
32	0,95249	ENVELOPE_ ULS	Min	-6,018E-15	-41,4717	32-1	0,95249
34	0,00000	USL1		1,838E-13	603,2894	34-1	0,00000
34	0,47625	USL1		2,149E-13	879,8295	34-1	0,47625
34	0,95249	USL1		2,459E-13	1142,8743	34-1	0,95249
34	0,00000	ULS2		4,882E-14	424,8125	34-1	0,00000
34	0,47625	ULS2		7,986E-14	678,3390	34-1	0,47625
34	0,95249	ULS2		1,109E-13	931,8655	34-1	0,95249
34	0,00000	ENVELOPE_ ULS	Max	1,838E-13	603,2894	34-1	0,00000
34	0,47625	ENVELOPE_ ULS	Max	2,149E-13	879,8295	34-1	0,47625
34	0,95249	ENVELOPE_ ULS	Max	2,459E-13	1142,8743	34-1	0,95249
34	0,00000	ENVELOPE_ ULS	Min	4,882E-14	424,8125	34-1	0,00000
34	0,47625	ENVELOPE_ ULS	Min	7,986E-14	678,3390	34-1	0,47625
34	0,95249	ENVELOPE_ ULS	Min	1,109E-13	931,8655	34-1	0,95249
35	0,00000	USL1		2,104E-13	1142,8743	35-1	0,00000
35	0,47625	USL1		1,987E-13	1155,7638	35-1	0,47625
35	0,95249	USL1		1,871E-13	1157,0973	35-1	0,95249
35	0,00000	ULS2		1,109E-13	931,8655	35-1	0,00000
35	0,47625	ULS2		1,128E-13	947,5776	35-1	0,47625
35	0,95249	ULS2		1,147E-13	963,2897	35-1	0,95249
35	0,00000	ENVELOPE_ ULS	Max	2,104E-13	1142,8743	35-1	0,00000
35	0,47625	ENVELOPE_ ULS	Max	1,987E-13	1155,7638	35-1	0,47625
35	0,95249	ENVELOPE_ ULS	Max	1,871E-13	1157,0973	35-1	0,95249
35	0,00000	ENVELOPE_ ULS	Min	1,109E-13	931,8655	35-1	0,00000
35	0,47625	ENVELOPE_ ULS	Min	1,128E-13	947,5776	35-1	0,47625
35	0,95249	ENVELOPE_ ULS	Min	1,147E-13	963,2897	35-1	0,95249
36	0,00000	USL1		1,858E-13	1157,0973	36-1	0,00000
36	0,47625	USL1		1,331E-13	923,2873	36-1	0,47625
36	0,95249	USL1		8,041E-14	679,8491	36-1	0,95249
36	0,00000	ULS2		1,147E-13	963,2897	36-1	0,00000
36	0,47625	ULS2		8,911E-14	754,3496	36-1	0,47625
36	0,95249	ULS2		6,350E-14	545,4095	36-1	0,95249
36	0,00000	ENVELOPE_ ULS	Max	1,858E-13	1157,0973	36-1	0,00000
36	0,47625	ENVELOPE_ ULS	Max	1,331E-13	923,2873	36-1	0,47625
36	0,95249	ENVELOPE_ ULS	Max	8,041E-14	679,8491	36-1	0,95249

Table: Element Forces - Frames, Part 2 of 2

Frame	Station m	OutputCase	StepType	M2 KN-m	M3 KN-m	FrameElem	ElemStation m
36	0,00000	ENVELOPE_ ULS	Min	1,147E-13	963,2897	36-1	0,00000
36	0,47625	ENVELOPE_ ULS	Min	8,911E-14	754,3496	36-1	0,47625
36	0,95249	ENVELOPE_ ULS	Min	6,350E-14	545,4095	36-1	0,95249
37	0,00000	USL1		5,793E-14	18,4444	37-1	0,00000
37	0,23812	USL1		3,271E-14	47,3046	37-1	0,23812
37	0,47625	USL1		7,497E-15	72,1858	37-1	0,47625
37	0,00000	ULS2		-6,018E-15	-41,4717	37-1	0,00000
37	0,23812	ULS2		-4,163E-15	-25,1556	37-1	0,23812
37	0,47625	ULS2		-2,309E-15	-8,8394	37-1	0,47625
37	0,00000	ENVELOPE_ ULS	Max	5,793E-14	18,4444	37-1	0,00000
37	0,23812	ENVELOPE_ ULS	Max	3,271E-14	47,3046	37-1	0,23812
37	0,47625	ENVELOPE_ ULS	Max	7,497E-15	72,1858	37-1	0,47625
37	0,00000	ENVELOPE_ ULS	Min	-6,018E-15	-41,4717	37-1	0,00000
37	0,23812	ENVELOPE_ ULS	Min	-4,163E-15	-25,1556	37-1	0,23812
37	0,47625	ENVELOPE_ ULS	Min	-2,309E-15	-8,8394	37-1	0,47625
38	0,00000	USL1		1,503E-13	60,1397	38-1	0,00000
38	0,23812	USL1		1,813E-13	333,5836	38-1	0,23812
38	0,47625	USL1		2,122E-13	603,2894	38-1	0,47625
38	0,00000	ULS2		-1,309E-14	-80,8739	38-1	0,00000
38	0,23812	ULS2		1,787E-14	171,9693	38-1	0,23812
38	0,47625	ULS2		4,882E-14	424,8125	38-1	0,47625
38	0,00000	ENVELOPE_ ULS	Max	1,503E-13	60,1397	38-1	0,00000
38	0,23812	ENVELOPE_ ULS	Max	1,813E-13	333,5836	38-1	0,23812
38	0,47625	ENVELOPE_ ULS	Max	2,122E-13	603,2894	38-1	0,47625
38	0,00000	ENVELOPE_ ULS	Min	-1,309E-14	-80,8739	38-1	0,00000
38	0,23812	ENVELOPE_ ULS	Min	1,787E-14	171,9693	38-1	0,23812
38	0,47625	ENVELOPE_ ULS	Min	4,882E-14	424,8125	38-1	0,47625
39	0,00000	USL1		8,974E-14	-82,0403	39-1	0,00000
39	1,04715	USL1		8,457E-14	-54,5998	39-1	1,04715
39	2,09431	USL1		8,125E-14	-12,0461	39-1	2,09431
39	0,00000	ULS2		-1,684E-14	-114,4108	39-1	0,00000
39	1,04715	ULS2		-1,457E-14	-100,7793	39-1	1,04715
39	2,09431	ULS2		-1,045E-14	-72,0345	39-1	2,09431
39	0,00000	ENVELOPE_ ULS	Max	8,974E-14	-82,0403	39-1	0,00000
39	1,04715	ENVELOPE_ ULS	Max	8,457E-14	-54,5998	39-1	1,04715
39	2,09431	ENVELOPE_ ULS	Max	8,125E-14	-12,0461	39-1	2,09431
39	0,00000	ENVELOPE_ ULS	Min	-1,684E-14	-114,4108	39-1	0,00000
39	1,04715	ENVELOPE_ ULS	Min	-1,457E-14	-100,7793	39-1	1,04715
39	2,09431	ENVELOPE_ ULS	Min	-1,045E-14	-72,0345	39-1	2,09431
40	0,00000	USL1		1,498E-13	165,2510	40-1	0,00000
40	1,03322	USL1		1,045E-13	-8,4847	40-1	1,03322
40	2,06644	USL1		6,087E-14	-167,6817	40-1	2,06644

Table: Element Forces - Frames, Part 2 of 2

Frame	Station m	OutputCase	StepType	M2 KN-m	M3 KN-m	FrameElem	ElemStation m
40	0,00000	ULS2		1,616E-14	134,3066	40-1	0,00000
40	1,03322	ULS2		-9,022E-15	-54,5123	40-1	1,03322
40	2,06644	ULS2		-3,243E-14	-228,7925	40-1	2,06644
40	0,00000	ENVELOPE_ ULS	Max	1,498E-13	165,2510	40-1	0,00000
40	1,03322	ENVELOPE_ ULS	Max	1,045E-13	-8,4847	40-1	1,03322
40	2,06644	ENVELOPE_ ULS	Max	6,087E-14	-167,6817	40-1	2,06644
40	0,00000	ENVELOPE_ ULS	Min	1,616E-14	134,3066	40-1	0,00000
40	1,03322	ENVELOPE_ ULS	Min	-9,022E-15	-54,5123	40-1	1,03322
40	2,06644	ENVELOPE_ ULS	Min	-3,243E-14	-228,7925	40-1	2,06644

Table: Element Joint Forces - Frames, Part 1 of 2

Table: Element Joint Forces - Frames, Part 1 of 2

Frame	Joint	OutputCase	CaseType	StepType	F1 KN	F2 KN	F3 KN	M1 KN-m
1	28	USL1	Combination		-214,060	1,424E-14	-1009,600	-3,943E-14
1	35	USL1	Combination		296,533	-1,424E-14	1027,555	5,366E-14
1	28	ULS2	Combination		-151,088	3,102E-17	-909,154	3,202E-15
1	35	ULS2	Combination		202,166	-3,102E-17	927,109	-3,187E-15
1	28	ENVELOPE_ ULS	Combination	Max	-151,088	1,424E-14	-909,154	3,202E-15
1	35	ENVELOPE_ ULS	Combination	Max	296,533	-3,102E-17	1027,555	5,366E-14
1	28	ENVELOPE_ ULS	Combination	Min	-214,060	3,102E-17	-1009,600	-3,943E-14
1	35	ENVELOPE_ ULS	Combination	Min	202,166	-1,424E-14	927,109	-3,187E-15
2	11	USL1	Combination		948,614	4,089E-14	995,420	1,128E-14
2	12	USL1	Combination		-976,927	-4,089E-14	-741,959	-2,374E-14
2	11	ULS2	Combination		866,322	3,102E-17	894,957	3,291E-15
2	12	ULS2	Combination		-866,322	-3,102E-17	-669,809	-3,316E-15
2	11	ENVELOPE_ ULS	Combination	Max	948,614	4,089E-14	995,420	1,128E-14
2	12	ENVELOPE_ ULS	Combination	Max	-866,322	-3,102E-17	-669,809	-3,316E-15
2	11	ENVELOPE_ ULS	Combination	Min	866,322	3,102E-17	894,957	3,291E-15
2	12	ENVELOPE_ ULS	Combination	Min	-976,927	-4,089E-14	-741,959	-2,374E-14
3	12	USL1	Combination		948,427	-4,793E-14	741,959	6,593E-14
3	13	USL1	Combination		-968,532	4,793E-14	-544,762	-5,352E-14
3	12	ULS2	Combination		837,822	3,102E-17	669,809	3,316E-15
3	13	ULS2	Combination		-837,822	-3,102E-17	-492,718	-3,338E-15
3	12	ENVELOPE_ ULS	Combination	Max	948,427	3,102E-17	741,959	6,593E-14
3	13	ENVELOPE_ ULS	Combination	Max	-837,822	4,793E-14	-492,718	-3,338E-15
3	12	ENVELOPE_ ULS	Combination	Min	837,822	-4,793E-14	669,809	3,316E-15
3	13	ENVELOPE_ ULS	Combination	Min	-968,532	-3,102E-17	-544,762	-5,352E-14
4	13	USL1	Combination		940,032	3,289E-14	544,762	8,727E-14
4	14	USL1	Combination		-954,380	-3,289E-14	-386,665	-1,033E-13
4	13	ULS2	Combination		809,322	3,102E-17	492,718	3,338E-15
4	14	ULS2	Combination		-809,322	-3,102E-17	-350,394	-3,359E-15

Table: Element Joint Forces - Frames, Part 1 of 2

Frame	Joint	OutputCase	CaseType	StepType	F1 KN	F2 KN	F3 KN	M1 KN-m
4	13	ENVELOPE_ ULS	Combination	Max	940,032	3,289E-14	544,762	8,727E-14
4	14	ENVELOPE_ ULS	Combination	Max	-809,322	-3,102E-17	-350,394	-3,359E-15
4	13	ENVELOPE_ ULS	Combination	Min	809,322	3,102E-17	492,718	3,338E-15
4	14	ENVELOPE_ ULS	Combination	Min	-954,380	-3,289E-14	-386,665	-1,033E-13
5	14	USL1	Combination		925,880	6,398E-14	386,665	9,862E-14
5	15	USL1	Combination		-934,145	-6,398E-14	-257,291	-1,410E-13
5	14	ULS2	Combination		780,822	3,102E-17	350,394	3,359E-15
5	15	ULS2	Combination		-780,822	-3,102E-17	-234,843	-3,375E-15
5	14	ENVELOPE_ ULS	Combination	Max	925,880	6,398E-14	386,665	9,862E-14
5	15	ENVELOPE_ ULS	Combination	Max	-780,822	-3,102E-17	-234,843	-3,375E-15
5	14	ENVELOPE_ ULS	Combination	Min	780,822	3,102E-17	350,394	3,359E-15
5	15	ENVELOPE_ ULS	Combination	Min	-934,145	-6,398E-14	-257,291	-1,410E-13
6	15	USL1	Combination		905,645	-7,546E-14	257,291	8,481E-14
6	16	USL1	Combination		-909,641	7,546E-14	-147,239	-7,222E-14
6	15	ULS2	Combination		752,322	3,102E-17	234,843	3,375E-15
6	16	ULS2	Combination		-752,322	-3,102E-17	-136,524	-3,385E-15
6	15	ENVELOPE_ ULS	Combination	Max	905,645	3,102E-17	257,291	8,481E-14
6	16	ENVELOPE_ ULS	Combination	Max	-752,322	7,546E-14	-136,524	-3,385E-15
6	15	ENVELOPE_ ULS	Combination	Min	752,322	-7,546E-14	234,843	3,375E-15
6	16	ENVELOPE_ ULS	Combination	Min	-909,641	-3,102E-17	-147,239	-7,222E-14
7	16	USL1	Combination		881,141	-1,447E-13	147,239	7,189E-14
7	17	USL1	Combination		-882,370	1,447E-13	-44,992	-6,334E-14
7	16	ULS2	Combination		723,822	3,102E-17	136,524	3,385E-15
7	17	ULS2	Combination		-723,822	-3,102E-17	-45,245	-3,388E-15
7	16	ENVELOPE_ ULS	Combination	Max	881,141	3,102E-17	147,239	7,189E-14
7	17	ENVELOPE_ ULS	Combination	Max	-723,822	1,447E-13	-44,992	-3,388E-15
7	16	ENVELOPE_ ULS	Combination	Min	723,822	-1,447E-13	136,524	3,385E-15
7	17	ENVELOPE_ ULS	Combination	Min	-882,370	-3,102E-17	-45,245	-6,334E-14
8	17	USL1	Combination		853,870	-1,225E-13	44,992	7,514E-14
8	18	USL1	Combination		-796,709	1,225E-13	60,879	-7,866E-14
8	17	ULS2	Combination		695,322	3,102E-17	45,245	3,388E-15
8	18	ULS2	Combination		-639,479	-3,102E-17	49,273	-3,384E-15
8	17	ENVELOPE_ ULS	Combination	Max	853,870	3,102E-17	45,245	7,514E-14
8	18	ENVELOPE_ ULS	Combination	Max	-639,479	1,225E-13	60,879	-3,384E-15
8	17	ENVELOPE_ ULS	Combination	Min	695,322	-1,225E-13	44,992	3,388E-15
8	18	ENVELOPE_ ULS	Combination	Min	-796,709	-3,102E-17	49,273	-7,866E-14
9	18	USL1	Combination		768,209	6,753E-14	-60,879	6,783E-14
9	19	USL1	Combination		-711,335	-6,753E-14	170,611	-6,444E-14
9	18	ULS2	Combination		610,979	3,102E-17	-49,273	3,384E-15
9	19	ULS2	Combination		-558,180	-3,102E-17	147,334	-3,374E-15
9	18	ENVELOPE_ ULS	Combination	Max	768,209	6,753E-14	-49,273	6,783E-14

Table: Element Joint Forces - Frames, Part 1 of 2

Frame	Joint	OutputCase	CaseType	StepType	F1 KN	F2 KN	F3 KN	M1 KN-m
9	19	ENVELOPE_ ULS	Combination	Max	-558,180	-3,102E-17	170,611	-3,374E-15
9	18	ENVELOPE_ ULS	Combination	Min	610,979	3,102E-17	-60,879	3,384E-15
9	19	ENVELOPE_ ULS	Combination	Min	-711,335	-6,753E-14	147,334	-6,444E-14
10	19	USL1	Combination		682,835	3,584E-15	-170,611	6,233E-14
10	20	USL1	Combination		-618,031	-3,584E-15	299,391	-8,729E-14
10	19	ULS2	Combination		529,680	3,102E-17	-147,334	3,374E-15
10	20	ULS2	Combination		-473,203	-3,102E-17	262,406	-3,359E-15
10	19	ENVELOPE_ ULS	Combination	Max	682,835	3,584E-15	-147,334	6,233E-14
10	20	ENVELOPE_ ULS	Combination	Max	-473,203	-3,102E-17	299,391	-3,359E-15
10	19	ENVELOPE_ ULS	Combination	Min	529,680	3,102E-17	-170,611	3,374E-15
10	20	ENVELOPE_ ULS	Combination	Min	-618,031	-3,584E-15	262,406	-8,729E-14
11	20	USL1	Combination		589,531	-1,030E-13	-299,391	5,398E-14
11	21	USL1	Combination		-513,490	1,030E-13	456,584	-1,024E-13
11	20	ULS2	Combination		444,703	3,102E-17	-262,406	3,359E-15
11	21	ULS2	Combination		-382,996	-3,102E-17	403,968	-3,338E-15
11	20	ENVELOPE_ ULS	Combination	Max	589,531	3,102E-17	-262,406	5,398E-14
11	21	ENVELOPE_ ULS	Combination	Max	-382,996	1,030E-13	456,584	-3,338E-15
11	20	ENVELOPE_ ULS	Combination	Min	444,703	-1,030E-13	-299,391	3,359E-15
11	21	ENVELOPE_ ULS	Combination	Min	-513,490	-3,102E-17	403,968	-1,024E-13
12	21	USL1	Combination		484,990	-1,507E-14	-456,584	3,931E-14
12	22	USL1	Combination		-394,807	1,507E-14	652,650	-1,059E-13
12	21	ULS2	Combination		354,496	3,102E-17	-403,968	3,338E-15
12	22	ULS2	Combination		-284,303	-3,102E-17	580,043	-3,316E-15
12	21	ENVELOPE_ ULS	Combination	Max	484,990	3,102E-17	-403,968	3,931E-14
12	22	ENVELOPE_ ULS	Combination	Max	-284,303	1,507E-14	652,650	-3,316E-15
12	21	ENVELOPE_ ULS	Combination	Min	354,496	-1,507E-14	-456,584	3,338E-15
12	22	ENVELOPE_ ULS	Combination	Min	-394,807	-3,102E-17	580,043	-1,059E-13
13	22	USL1	Combination		366,307	8,913E-15	-652,650	8,636E-14
13	31	USL1	Combination		-252,274	-8,913E-15	901,870	-8,545E-14
13	22	ULS2	Combination		255,803	3,102E-17	-580,043	3,316E-15
13	31	ULS2	Combination		-169,609	-3,102E-17	801,425	-3,291E-15
13	22	ENVELOPE_ ULS	Combination	Max	366,307	8,913E-15	-580,043	8,636E-14
13	31	ENVELOPE_ ULS	Combination	Max	-169,609	-3,102E-17	901,870	-3,291E-15
13	22	ENVELOPE_ ULS	Combination	Min	255,803	3,102E-17	-652,650	3,316E-15
13	31	ENVELOPE_ ULS	Combination	Min	-252,274	-8,913E-15	801,425	-8,545E-14
14	31	USL1	Combination		223,774	-2,129E-14	-901,870	8,145E-14
14	30	USL1	Combination		-103,617	2,129E-14	937,780	-7,432E-14
14	31	ULS2	Combination		141,109	3,102E-17	-801,425	3,291E-15
14	30	ULS2	Combination		-61,386	-3,102E-17	837,335	-3,261E-15
14	31	ENVELOPE_ ULS	Combination	Max	223,774	3,102E-17	-801,425	8,145E-14
14	30	ENVELOPE_ ULS	Combination	Max	-61,386	2,129E-14	937,780	-3,261E-15

Table: Element Joint Forces - Frames, Part 1 of 2

Frame	Joint	OutputCase	CaseType	StepType	F1 KN	F2 KN	F3 KN	M1 KN-m
14	31	ENVELOPE_ ULS	Combination	Min	141,109	-2,129E-14	-901,870	3,291E-15
14	30	ENVELOPE_ ULS	Combination	Min	-103,617	-3,102E-17	837,335	-7,432E-14
15	30	USL1	Combination		94,117	1,137E-13	-937,780	6,543E-14
15	29	USL1	Combination		42,327	-1,137E-13	973,690	6,782E-14
15	30	ULS2	Combination		51,886	3,102E-17	-837,335	3,261E-15
15	29	ULS2	Combination		36,029	-3,102E-17	873,244	-3,232E-15
15	30	ENVELOPE_ ULS	Combination	Max	94,117	1,137E-13	-837,335	6,543E-14
15	29	ENVELOPE_ ULS	Combination	Max	42,327	-3,102E-17	973,690	6,782E-14
15	30	ENVELOPE_ ULS	Combination	Min	51,886	3,102E-17	-937,780	3,261E-15
15	29	ENVELOPE_ ULS	Combination	Min	36,029	-1,137E-13	873,244	-3,232E-15
16	29	USL1	Combination		-51,827	-1,418E-14	-973,690	-2,519E-14
16	28	USL1	Combination		204,560	1,418E-14	1009,600	3,943E-14
16	29	ULS2	Combination		-45,529	3,102E-17	-873,244	3,232E-15
16	28	ULS2	Combination		141,588	-3,102E-17	909,154	-3,202E-15
16	29	ENVELOPE_ ULS	Combination	Max	-45,529	3,102E-17	-873,244	3,232E-15
16	28	ENVELOPE_ ULS	Combination	Max	204,560	1,418E-14	1009,600	3,943E-14
16	29	ENVELOPE_ ULS	Combination	Min	-51,827	-1,418E-14	-973,690	-2,519E-14
16	28	ENVELOPE_ ULS	Combination	Min	141,588	-3,102E-17	909,154	-3,202E-15
18	27	USL1	Combination		61,867	4,777E-14	-389,009	1,336E-15
18	32	USL1	Combination		123,440	-4,777E-14	406,963	3,410E-14
18	27	ULS2	Combination		122,269	-1,965E-15	-332,845	-4,401E-16
18	32	ULS2	Combination		-9,875	1,965E-15	350,800	-1,432E-15
18	27	ENVELOPE_ ULS	Combination	Max	122,269	4,777E-14	-332,845	1,336E-15
18	32	ENVELOPE_ ULS	Combination	Max	123,440	1,965E-15	406,963	3,410E-14
18	27	ENVELOPE_ ULS	Combination	Min	61,867	-1,965E-15	-389,009	-4,401E-16
18	32	ENVELOPE_ ULS	Combination	Min	-9,875	-4,777E-14	350,800	-1,432E-15
19	32	USL1	Combination		-132,940	1,515E-14	-214,372	-2,877E-14
19	33	USL1	Combination		132,940	-7,569E-15	166,941	2,877E-14
19	32	ULS2	Combination		0,375	-1,965E-15	-94,159	1,432E-15
19	33	ULS2	Combination		-0,375	1,965E-15	108,592	-1,432E-15
19	32	ENVELOPE_ ULS	Combination	Max	0,375	1,515E-14	-94,159	1,432E-15
19	33	ENVELOPE_ ULS	Combination	Max	132,940	1,965E-15	166,941	2,877E-14
19	32	ENVELOPE_ ULS	Combination	Min	-132,940	-1,965E-15	-214,372	-2,877E-14
19	33	ENVELOPE_ ULS	Combination	Min	-0,375	-7,569E-15	108,592	-1,432E-15
20	33	USL1	Combination		-142,440	2,206E-14	-166,941	-3,410E-14
20	9	USL1	Combination		142,440	-1,486E-14	121,885	3,410E-14
20	33	ULS2	Combination		-9,125	-1,965E-15	-108,592	1,432E-15
20	9	ULS2	Combination		9,125	1,965E-15	122,302	-1,432E-15
20	33	ENVELOPE_ ULS	Combination	Max	-9,125	2,206E-14	-108,592	1,432E-15
20	9	ENVELOPE_ ULS	Combination	Max	142,440	1,965E-15	122,302	3,410E-14
20	33	ENVELOPE_ ULS	Combination	Min	-142,440	-1,965E-15	-166,941	-3,410E-14

Table: Element Joint Forces - Frames, Part 1 of 2

Frame	Joint	OutputCase	CaseType	StepType	F1 KN	F2 KN	F3 KN	M1 KN-m
20	9	ENVELOPE_	Combination	Min	9,125	-1,486E-14	121,885	-1,432E-15
		ULS						
21	9	USL1	Combination		-615,887	-5,558E-15	-630,988	-1,069E-13
21	8	USL1	Combination		795,931	1,582E-14	591,041	8,514E-14
21	9	ULS2	Combination		-415,185	3,102E-17	-523,695	3,143E-15
21	8	ULS2	Combination		540,588	-3,102E-17	547,287	-3,123E-15
21	9	ENVELOPE_	Combination	Max	-415,185	3,102E-17	-523,695	3,143E-15
		ULS						
21	8	ENVELOPE_	Combination	Max	795,931	1,582E-14	591,041	8,514E-14
		ULS						
21	9	ENVELOPE_	Combination	Min	-615,887	-5,558E-15	-630,988	-1,069E-13
		ULS						
21	8	ENVELOPE_	Combination	Min	540,588	-3,102E-17	547,287	-3,123E-15
		ULS						
22	8	USL1	Combination		-805,431	-2,656E-14	-420,674	-8,435E-14
22	7	USL1	Combination		980,551	3,743E-14	367,653	7,326E-14
22	8	ULS2	Combination		-550,088	3,102E-17	-314,105	3,123E-15
22	7	ULS2	Combination		680,330	-3,102E-17	337,621	-3,107E-15
22	8	ENVELOPE_	Combination	Max	-550,088	3,102E-17	-314,105	3,123E-15
		ULS						
22	7	ENVELOPE_	Combination	Max	980,551	3,743E-14	367,653	7,326E-14
		ULS						
22	8	ENVELOPE_	Combination	Min	-805,431	-2,656E-14	-420,674	-8,435E-14
		ULS						
22	7	ENVELOPE_	Combination	Min	680,330	-3,102E-17	337,621	-3,107E-15
		ULS						
23	7	USL1	Combination		-990,051	-2,542E-14	-204,174	-7,198E-14
23	6	USL1	Combination		1153,300	3,675E-14	139,997	6,011E-14
23	7	ULS2	Combination		-689,830	3,102E-17	-112,042	3,107E-15
23	6	ULS2	Combination		823,820	-3,102E-17	135,569	-3,097E-15
23	7	ENVELOPE_	Combination	Max	-689,830	3,102E-17	-112,042	3,107E-15
		ULS						
23	6	ENVELOPE_	Combination	Max	1153,300	3,675E-14	139,997	6,011E-14
		ULS						
23	7	ENVELOPE_	Combination	Min	-990,051	-2,542E-14	-204,174	-7,198E-14
		ULS						
23	6	ENVELOPE_	Combination	Min	823,820	-3,102E-17	135,569	-3,097E-15
		ULS						
24	6	USL1	Combination		-1162,800	-7,654E-14	16,702	-6,918E-14
24	5	USL1	Combination		1316,514	8,862E-14	-90,133	5,541E-14
24	6	ULS2	Combination		-833,320	3,102E-17	82,671	3,097E-15
24	5	ULS2	Combination		976,317	-3,102E-17	-58,085	-3,094E-15
24	6	ENVELOPE_	Combination	Max	-833,320	3,102E-17	82,671	3,097E-15
		ULS						
24	5	ENVELOPE_	Combination	Max	1316,514	8,862E-14	-58,085	5,541E-14
		ULS						
24	6	ENVELOPE_	Combination	Min	-1162,800	-7,654E-14	16,702	-6,918E-14
		ULS						
24	5	ENVELOPE_	Combination	Min	976,317	-3,102E-17	-90,133	-3,094E-15
		ULS						
25	5	USL1	Combination		-1326,014	-3,855E-14	239,665	-5,790E-14
25	4	USL1	Combination		1316,048	5,019E-14	-310,515	6,639E-14
25	5	ULS2	Combination		-985,817	3,102E-17	268,983	3,094E-15
25	4	ULS2	Combination		985,817	-3,102E-17	-245,275	-3,097E-15
25	5	ENVELOPE_	Combination	Max	-985,817	3,102E-17	268,983	3,094E-15
		ULS						
25	4	ENVELOPE_	Combination	Max	1316,048	5,019E-14	-245,275	6,639E-14
		ULS						
25	5	ENVELOPE_	Combination	Min	-1326,014	-3,855E-14	239,665	-5,790E-14
		ULS						
25	4	ENVELOPE_	Combination	Min	985,817	-3,102E-17	-310,515	-3,097E-15
		ULS						
26	35	USL1	Combination		157,913	5,488E-14	-380,031	3,770E-14

Table: Element Joint Forces - Frames, Part 1 of 2

Frame	Joint	OutputCase	CaseType	StepType	F1 KN	F2 KN	F3 KN	M1 KN-m
26	27	USL1	Combination		-71,367	-5,488E-14	389,009	-6,665E-15
26	35	ULS2	Combination		184,895	-1,965E-15	-323,868	-1,376E-15
26	27	ULS2	Combination		-131,769	1,965E-15	332,845	4,401E-16
26	35	ENVELOPE_ ULS	Combination	Max	184,895	5,488E-14	-323,868	3,770E-14
26	27	ENVELOPE_ ULS	Combination	Max	-71,367	1,965E-15	389,009	4,401E-16
26	35	ENVELOPE_ ULS	Combination	Min	157,913	-1,965E-15	-380,031	-1,376E-15
26	27	ENVELOPE_ ULS	Combination	Min	-131,769	-5,488E-14	332,845	-6,665E-15
27	4	USL1	Combination		-1325,548	-4,033E-15	452,735	-5,693E-14
27	3	USL1	Combination		1296,881	1,538E-14	-517,292	5,980E-14
27	4	ULS2	Combination		-995,317	3,102E-17	449,179	3,097E-15
27	3	ULS2	Combination		995,317	-3,102E-17	-425,594	-3,107E-15
27	4	ENVELOPE_ ULS	Combination	Max	-995,317	3,102E-17	452,735	3,097E-15
27	3	ENVELOPE_ ULS	Combination	Max	1296,881	1,538E-14	-425,594	5,980E-14
27	4	ENVELOPE_ ULS	Combination	Min	-1325,548	-4,033E-15	449,179	-5,693E-14
27	3	ENVELOPE_ ULS	Combination	Min	995,317	-3,102E-17	-517,292	-3,107E-15
28	3	USL1	Combination		-1306,381	-3,710E-14	651,757	-8,173E-14
28	2	USL1	Combination		1261,849	4,801E-14	-705,298	8,260E-14
28	3	ULS2	Combination		-1004,817	3,102E-17	622,449	3,107E-15
28	2	ULS2	Combination		1004,817	-3,102E-17	-598,838	-3,122E-15
28	3	ENVELOPE_ ULS	Combination	Max	-1004,817	3,102E-17	651,757	3,107E-15
28	2	ENVELOPE_ ULS	Combination	Max	1261,849	4,801E-14	-598,838	8,260E-14
28	3	ENVELOPE_ ULS	Combination	Min	-1306,381	-3,710E-14	622,449	-8,173E-14
28	2	ENVELOPE_ ULS	Combination	Min	1004,817	-3,102E-17	-705,298	-3,122E-15
29	2	USL1	Combination		-1271,349	-1,430E-14	831,811	-1,269E-13
29	1	USL1	Combination		1215,182	2,459E-14	-870,590	1,151E-13
29	2	ULS2	Combination		-1014,317	3,102E-17	788,607	3,122E-15
29	1	ULS2	Combination		1014,317	-3,102E-17	-764,968	-3,143E-15
29	2	ENVELOPE_ ULS	Combination	Max	-1014,317	3,102E-17	831,811	3,122E-15
29	1	ENVELOPE_ ULS	Combination	Max	1215,182	2,459E-14	-764,968	1,151E-13
29	2	ENVELOPE_ ULS	Combination	Min	-1271,349	-1,430E-14	788,607	-1,269E-13
29	1	ENVELOPE_ ULS	Combination	Min	1014,317	-3,102E-17	-870,590	-3,143E-15
30	1	USL1	Combination		-174,136	-1,604E-14	35,440	-3,694E-14
30	34	USL1	Combination		174,136	2,361E-14	-82,871	3,694E-14
30	1	ULS2	Combination		-40,020	6,040E-16	38,055	3,634E-16
30	34	ULS2	Combination		40,020	-6,040E-16	-23,622	-3,634E-16
30	1	ENVELOPE_ ULS	Combination	Max	-40,020	6,040E-16	38,055	3,634E-16
30	34	ENVELOPE_ ULS	Combination	Max	174,136	2,361E-14	-23,622	3,694E-14
30	1	ENVELOPE_ ULS	Combination	Min	-174,136	-1,604E-14	35,440	-3,694E-14
30	34	ENVELOPE_ ULS	Combination	Min	40,020	-6,040E-16	-82,871	-3,634E-16
31	34	USL1	Combination		-183,636	7,945E-15	82,871	-3,228E-14
31	10	USL1	Combination		183,636	-3,687E-16	-130,302	3,087E-14
31	34	ULS2	Combination		-49,520	6,040E-16	23,622	3,634E-16

Table: Element Joint Forces - Frames, Part 1 of 2

Frame	Joint	OutputCase	CaseType	StepType	F1 KN	F2 KN	F3 KN	M1 KN-m
31	10	ULS2	Combination		49,520	-6,040E-16	-9,189	-3,634E-16
31	34	ENVELOPE_ ULS	Combination	Max	-49,520	7,945E-15	82,871	3,634E-16
31	10	ENVELOPE_ ULS	Combination	Max	183,636	-3,687E-16	-9,189	3,087E-14
31	34	ENVELOPE_ ULS	Combination	Min	-183,636	6,040E-16	23,622	-3,228E-14
31	10	ENVELOPE_ ULS	Combination	Min	49,520	-6,040E-16	-130,302	-3,634E-16
32	10	USL1	Combination		-193,136	-2,423E-14	233,289	-4,346E-14
32	23	USL1	Combination		120,223	3,316E-14	-215,334	5,018E-14
32	10	ULS2	Combination		-59,020	6,040E-16	177,070	3,634E-16
32	23	ULS2	Combination		59,020	-6,040E-16	-159,115	-9,387E-16
32	10	ENVELOPE_ ULS	Combination	Max	-59,020	6,040E-16	233,289	3,634E-16
32	23	ENVELOPE_ ULS	Combination	Max	120,223	3,316E-14	-159,115	5,018E-14
32	10	ENVELOPE_ ULS	Combination	Min	-193,136	-2,423E-14	177,070	-4,346E-14
32	23	ENVELOPE_ ULS	Combination	Min	59,020	-6,040E-16	-215,334	-9,387E-16
34	24	USL1	Combination		-595,517	4,333E-15	1103,149	-1,059E-13
34	25	USL1	Combination		538,844	2,608E-15	-1067,239	1,131E-13
34	24	ULS2	Combination		-532,343	3,102E-17	1002,687	3,202E-15
34	25	ULS2	Combination		532,343	-3,102E-17	-966,777	-3,232E-15
34	24	ENVELOPE_ ULS	Combination	Max	-532,343	4,333E-15	1103,149	3,202E-15
34	25	ENVELOPE_ ULS	Combination	Max	538,844	2,608E-15	-966,777	1,131E-13
34	24	ENVELOPE_ ULS	Combination	Min	-595,517	3,102E-17	1002,687	-1,059E-13
34	25	ENVELOPE_ ULS	Combination	Min	532,343	-3,102E-17	-1067,239	-3,232E-15
35	25	USL1	Combination		-39,872	2,650E-14	1067,239	-7,794E-14
35	26	USL1	Combination		-8,658	-2,055E-14	-1031,329	5,460E-14
35	25	ULS2	Combination		-32,991	3,102E-17	966,777	3,232E-15
35	26	ULS2	Combination		32,991	-3,102E-17	-930,867	-3,261E-15
35	25	ENVELOPE_ ULS	Combination	Max	-32,991	2,650E-14	1067,239	3,232E-15
35	26	ENVELOPE_ ULS	Combination	Max	32,991	-3,102E-17	-930,867	5,460E-14
35	25	ENVELOPE_ ULS	Combination	Min	-39,872	3,102E-17	966,777	-7,794E-14
35	26	ENVELOPE_ ULS	Combination	Min	-8,658	-2,055E-14	-1031,329	-3,261E-15
36	26	USL1	Combination		480,161	6,359E-14	1031,329	-3,791E-14
36	11	USL1	Combination		-520,594	-5,864E-14	-995,420	-3,004E-14
36	26	ULS2	Combination		438,723	3,102E-17	930,867	3,261E-15
36	11	ULS2	Combination		-438,723	-3,102E-17	-894,957	-3,291E-15
36	26	ENVELOPE_ ULS	Combination	Max	480,161	6,359E-14	1031,329	3,261E-15
36	11	ENVELOPE_ ULS	Combination	Max	-438,723	-3,102E-17	-894,957	-3,291E-15
36	26	ENVELOPE_ ULS	Combination	Min	438,723	3,102E-17	930,867	-3,791E-14
36	11	ENVELOPE_ ULS	Combination	Min	-520,594	-5,864E-14	-995,420	-3,004E-14
37	23	USL1	Combination		-129,723	9,559E-14	215,334	-5,430E-14
37	36	USL1	Combination		96,302	-9,150E-14	-206,357	2,178E-14
37	23	ULS2	Combination		-68,520	6,040E-16	159,115	9,387E-16
37	36	ULS2	Combination		68,520	-6,040E-16	-150,137	-1,226E-15
37	23	ENVELOPE_ ULS	Combination	Max	-68,520	9,559E-14	215,334	9,387E-16

Table: Element Joint Forces - Frames, Part 1 of 2

Frame	Joint	OutputCase	CaseType	StepType	F1 KN	F2 KN	F3 KN	M1 KN-m
37	36	ENVELOPE_ ULS	Combination	Max	96,302	-6,040E-16	-150,137	2,178E-14
37	23	ENVELOPE_ ULS	Combination	Min	-129,723	6,040E-16	159,115	-5,430E-14
37	36	ENVELOPE_ ULS	Combination	Min	68,520	-9,150E-14	-206,357	-1,226E-15
38	36	USL1	Combination		-1156,348	1,431E-13	1121,104	-1,456E-13
38	24	USL1	Combination		1124,951	-1,393E-13	-1103,149	1,034E-13
38	36	ULS2	Combination		-1061,817	3,102E-17	1020,642	3,187E-15
38	24	ULS2	Combination		1061,817	-3,102E-17	-1002,687	-3,202E-15
38	36	ENVELOPE_ ULS	Combination	Max	-1061,817	1,431E-13	1121,104	3,187E-15
38	24	ENVELOPE_ ULS	Combination	Max	1124,951	-3,102E-17	-1002,687	1,034E-13
38	36	ENVELOPE_ ULS	Combination	Min	-1156,348	3,102E-17	1020,642	-1,456E-13
38	24	ENVELOPE_ ULS	Combination	Min	1061,817	-1,393E-13	-1103,149	-3,202E-15
39	1	USL1	Combination		-1050,546	5,644E-15	954,226	-7,516E-14
39	36	USL1	Combination		1050,546	-5,644E-15	-914,748	6,376E-14
39	1	ULS2	Combination		-983,797	-5,730E-16	909,983	2,780E-15
39	36	ULS2	Combination		983,797	5,730E-16	-870,505	-1,961E-15
39	1	ENVELOPE_ ULS	Combination	Max	-983,797	5,644E-15	954,226	2,780E-15
39	36	ENVELOPE_ ULS	Combination	Max	1050,546	5,730E-16	-870,505	6,376E-14
39	1	ENVELOPE_ ULS	Combination	Min	-1050,546	-5,730E-16	909,983	-7,516E-14
39	36	ENVELOPE_ ULS	Combination	Min	983,797	-5,644E-15	-914,748	-1,961E-15
40	9	USL1	Combination		463,947	-1,665E-14	686,477	7,156E-14
40	35	USL1	Combination		-463,947	1,665E-14	-647,524	-3,807E-14
40	9	ULS2	Combination		396,560	-1,996E-15	642,195	-1,711E-15
40	35	ULS2	Combination		-396,560	1,996E-15	-603,242	4,563E-15
40	9	ENVELOPE_ ULS	Combination	Max	463,947	-1,996E-15	686,477	7,156E-14
40	35	ENVELOPE_ ULS	Combination	Max	-396,560	1,665E-14	-603,242	4,563E-15
40	9	ENVELOPE_ ULS	Combination	Min	396,560	-1,665E-14	642,195	-1,711E-15
40	35	ENVELOPE_ ULS	Combination	Min	-463,947	1,996E-15	-647,524	-3,807E-14

Table: Element Joint Forces - Frames, Part 2 of 2

Table: Element Joint Forces - Frames, Part 2 of 2

Frame	Joint	OutputCase	StepType	M2 KN-m	M3 KN-m	FrameElem
1	28	USL1		-157,3147	1,208E-13	1-1
1	35	USL1		278,7371	-1,208E-13	1-1
1	28	ULS2		-336,5321	-3,113E-17	1-1
1	35	ULS2		420,5688	3,113E-17	1-1
1	28	ENVELOPE_ ULS	Max	-157,3147	1,208E-13	1-1
1	35	ENVELOPE_ ULS	Max	420,5688	3,113E-17	1-1
1	28	ENVELOPE_ ULS	Min	-336,5321	-3,113E-17	1-1
1	35	ENVELOPE_ ULS	Min	278,7371	-1,208E-13	1-1
2	11	USL1		679,8491	-1,107E-13	2-1

Table: Element Joint Forces - Frames, Part 2 of 2

Frame	Joint	OutputCase	StepType	M2	M3	FrameElem
				KN-m	KN-m	
2	12	USL1		-602,0602	1,170E-13	2-1
2	11	ULS2		545,4095	2,851E-16	2-1
2	12	ULS2		-476,7232	-2,597E-16	2-1
2	11	ENVELOPE_ ULS	Max	679,8491	2,851E-16	2-1
2	12	ENVELOPE_ ULS	Max	-476,7232	1,170E-13	2-1
2	11	ENVELOPE_ ULS	Min	545,4095	-1,107E-13	2-1
2	12	ENVELOPE_ ULS	Min	-602,0602	-2,597E-16	2-1
3	12	USL1		602,0602	-1,747E-13	3-1
3	13	USL1		-373,1784	1,561E-13	3-1
3	12	ULS2		476,7232	2,597E-16	3-1
3	13	ULS2		-290,8387	-2,372E-16	3-1
3	12	ENVELOPE_ ULS	Max	602,0602	2,597E-16	3-1
3	13	ENVELOPE_ ULS	Max	-290,8387	1,561E-13	3-1
3	12	ENVELOPE_ ULS	Min	476,7232	-1,747E-13	3-1
3	13	ENVELOPE_ ULS	Min	-373,1784	-2,372E-16	3-1
4	13	USL1		373,1784	-1,259E-13	4-1
4	14	USL1		-82,9401	1,446E-13	4-1
4	13	ULS2		290,8387	2,372E-16	4-1
4	14	ULS2		-60,5620	-2,145E-16	4-1
4	13	ENVELOPE_ ULS	Max	373,1784	2,372E-16	4-1
4	14	ENVELOPE_ ULS	Max	-60,5620	1,446E-13	4-1
4	13	ENVELOPE_ ULS	Min	290,8387	-1,259E-13	4-1
4	14	ENVELOPE_ ULS	Min	-82,9401	-2,145E-16	4-1
5	14	USL1		82,9401	-1,468E-13	5-1
5	15	USL1		115,9396	2,005E-13	5-1
5	14	ULS2		60,5620	2,145E-16	5-1
5	15	ULS2		87,1961	-1,882E-16	5-1
5	14	ENVELOPE_ ULS	Max	82,9401	2,145E-16	5-1
5	15	ENVELOPE_ ULS	Max	115,9396	2,005E-13	5-1
5	14	ENVELOPE_ ULS	Min	60,5620	-1,468E-13	5-1
5	15	ENVELOPE_ ULS	Min	87,1961	-1,882E-16	5-1
6	15	USL1		-115,9396	-1,046E-13	6-1
6	16	USL1		216,1279	7,978E-14	6-1
6	15	ULS2		-87,1961	1,882E-16	6-1
6	16	ULS2		153,1872	-1,592E-16	6-1
6	15	ENVELOPE_ ULS	Max	-87,1961	1,882E-16	6-1
6	16	ENVELOPE_ ULS	Max	216,1279	7,978E-14	6-1
6	15	ENVELOPE_ ULS	Min	-115,9396	-1,046E-13	6-1
6	16	ENVELOPE_ ULS	Min	153,1872	-1,592E-16	6-1
7	16	USL1		-216,1279	-5,247E-14	7-1
7	17	USL1		218,9654	-1,079E-14	7-1
7	16	ULS2		-153,1872	1,592E-16	7-1

Table: Element Joint Forces - Frames, Part 2 of 2

Frame	Joint	OutputCase	StepType	M2 KN-m	M3 KN-m	FrameElem
7	17	ULS2		142,9740	-1,270E-16	7-1
7	16	ENVELOPE_ ULS	Max	-153,1872	1,592E-16	7-1
7	17	ENVELOPE_ ULS	Max	218,9654	-1,270E-16	7-1
7	16	ENVELOPE_ ULS	Min	-216,1279	-5,247E-14	7-1
7	17	ENVELOPE_ ULS	Min	142,9740	-1,079E-14	7-1
8	17	USL1		-218,9654	-3,995E-14	8-1
8	18	USL1		124,3620	-7,559E-14	8-1
8	17	ULS2		-142,9740	1,270E-16	8-1
8	18	ULS2		61,8086	-9,359E-17	8-1
8	17	ENVELOPE_ ULS	Max	-142,9740	1,270E-16	8-1
8	18	ENVELOPE_ ULS	Max	124,3620	-9,359E-17	8-1
8	17	ENVELOPE_ ULS	Min	-218,9654	-3,995E-14	8-1
8	18	ENVELOPE_ ULS	Min	61,8086	-7,559E-14	8-1
9	18	USL1		-124,3620	3,917E-14	9-1
9	19	USL1		-8,5679	-2,671E-14	9-1
9	18	ULS2		-61,8086	9,359E-17	9-1
9	19	ULS2		-36,7056	-6,475E-17	9-1
9	18	ENVELOPE_ ULS	Max	-61,8086	3,917E-14	9-1
9	19	ENVELOPE_ ULS	Max	-8,5679	-6,475E-17	9-1
9	18	ENVELOPE_ ULS	Min	-124,3620	9,359E-17	9-1
9	19	ENVELOPE_ ULS	Min	-36,7056	-2,671E-14	9-1
10	19	USL1		8,5679	-6,152E-15	10-1
10	20	USL1		-143,7411	-2,580E-14	10-1
10	19	ULS2		36,7056	6,475E-17	10-1
10	20	ULS2		-120,7429	-3,867E-17	10-1
10	19	ENVELOPE_ ULS	Max	36,7056	6,475E-17	10-1
10	20	ENVELOPE_ ULS	Max	-120,7429	-3,867E-17	10-1
10	19	ENVELOPE_ ULS	Min	8,5679	-6,152E-15	10-1
10	20	ENVELOPE_ ULS	Min	-143,7411	-2,580E-14	10-1
11	20	USL1		143,7411	-3,070E-15	11-1
11	21	USL1		-237,2065	-4,531E-14	11-1
11	20	ULS2		120,7429	3,867E-17	11-1
11	21	ULS2		-154,6630	-1,617E-17	11-1
11	20	ENVELOPE_ ULS	Max	143,7411	3,867E-17	11-1
11	21	ENVELOPE_ ULS	Max	-154,6630	-1,617E-17	11-1
11	20	ENVELOPE_ ULS	Min	120,7429	-3,070E-15	11-1
11	21	ENVELOPE_ ULS	Min	-237,2065	-4,531E-14	11-1
12	21	USL1		237,2065	1,556E-14	12-1
12	22	USL1		-155,5197	-8,526E-14	12-1
12	21	ULS2		154,6630	1,617E-17	12-1
12	22	ULS2		-30,7132	6,174E-18	12-1
12	21	ENVELOPE_ ULS	Max	237,2065	1,556E-14	12-1

Table: Element Joint Forces - Frames, Part 2 of 2

Frame	Joint	OutputCase	StepType	M2	M3	FrameElem
				KN-m	KN-m	
12	22	ENVELOPE_ ULS	Max	-30,7132	6,174E-18	12-1
12	21	ENVELOPE_ ULS	Min	154,6630	1,617E-17	12-1
12	22	ENVELOPE_ ULS	Min	-155,5197	-8,526E-14	12-1
13	22	USL1		155,5197	8,259E-14	13-1
13	31	USL1		219,6735	-7,102E-14	13-1
13	22	ULS2		30,7132	-6,174E-18	13-1
13	31	ULS2		353,3498	3,113E-17	13-1
13	22	ENVELOPE_ ULS	Max	155,5197	8,259E-14	13-1
13	31	ENVELOPE_ ULS	Max	353,3498	3,113E-17	13-1
13	22	ENVELOPE_ ULS	Min	30,7132	-6,174E-18	13-1
13	31	ENVELOPE_ ULS	Min	219,6735	-7,102E-14	13-1
14	31	USL1		-219,6735	1,225E-13	14-1
14	30	USL1		62,4618	-1,225E-13	14-1
14	31	ULS2		-353,3498	-3,113E-17	14-1
14	30	ULS2		256,2622	3,113E-17	14-1
14	31	ENVELOPE_ ULS	Max	-219,6735	1,225E-13	14-1
14	30	ENVELOPE_ ULS	Max	256,2622	3,113E-17	14-1
14	31	ENVELOPE_ ULS	Min	-353,3498	-3,113E-17	14-1
14	30	ENVELOPE_ ULS	Min	62,4618	-1,225E-13	14-1
15	30	USL1		-62,4618	1,225E-13	15-1
15	29	USL1		36,5042	-1,225E-13	15-1
15	30	ULS2		-256,2622	-3,113E-17	15-1
15	29	ULS2		248,0606	3,113E-17	15-1
15	30	ENVELOPE_ ULS	Max	-62,4618	1,225E-13	15-1
15	29	ENVELOPE_ ULS	Max	248,0606	3,113E-17	15-1
15	30	ENVELOPE_ ULS	Min	-256,2622	-3,113E-17	15-1
15	29	ENVELOPE_ ULS	Min	36,5042	-1,225E-13	15-1
16	29	USL1		-36,5042	1,190E-13	16-1
16	28	USL1		157,3147	-1,190E-13	16-1
16	29	ULS2		-248,0606	-3,113E-17	16-1
16	28	ULS2		336,5321	3,113E-17	16-1
16	29	ENVELOPE_ ULS	Max	-36,5042	1,190E-13	16-1
16	28	ENVELOPE_ ULS	Max	336,5321	3,113E-17	16-1
16	29	ENVELOPE_ ULS	Min	-248,0606	-3,113E-17	16-1
16	28	ENVELOPE_ ULS	Min	157,3147	-1,190E-13	16-1
18	27	USL1		-56,2967	4,300E-14	18-1
18	32	USL1		84,3277	-4,300E-14	18-1
18	27	ULS2		-116,2901	1,704E-15	18-1
18	32	ULS2		52,7065	-1,704E-15	18-1
18	27	ENVELOPE_ ULS	Max	-56,2967	4,300E-14	18-1
18	32	ENVELOPE_ ULS	Max	84,3277	-1,704E-15	18-1

Table: Element Joint Forces - Frames, Part 2 of 2

Frame	Joint	OutputCase	StepType	M2	M3	FrameElem
				KN-m	KN-m	
18	27	ENVELOPE_ ULS	Min	-116,2901	1,704E-15	18-1
18	32	ENVELOPE_ ULS	Min	52,7065	-4,300E-14	18-1
19	32	USL1		-84,3277	5,762E-14	19-1
19	33	USL1		-61,6467	-6,544E-14	19-1
19	32	ULS2		-52,7065	1,704E-15	19-1
19	33	ULS2		-24,9108	-1,991E-16	19-1
19	32	ENVELOPE_ ULS	Max	-52,7065	5,762E-14	19-1
19	33	ENVELOPE_ ULS	Max	-24,9108	-1,991E-16	19-1
19	32	ENVELOPE_ ULS	Min	-84,3277	1,704E-15	19-1
19	33	ENVELOPE_ ULS	Min	-61,6467	-6,544E-14	19-1
20	33	USL1		61,6467	6,238E-14	20-1
20	9	USL1		-166,6783	-8,537E-14	20-1
20	33	ULS2		24,9108	1,991E-16	20-1
20	9	ULS2		-108,8753	1,230E-15	20-1
20	33	ENVELOPE_ ULS	Max	61,6467	6,238E-14	20-1
20	9	ENVELOPE_ ULS	Max	-108,8753	1,230E-15	20-1
20	33	ENVELOPE_ ULS	Min	24,9108	1,991E-16	20-1
20	9	ENVELOPE_ ULS	Min	-166,6783	-8,537E-14	20-1
21	9	USL1		331,9293	1,939E-13	21-1
21	8	USL1		-335,7411	-1,717E-13	21-1
21	9	ULS2		243,1819	1,518E-17	21-1
21	8	ULS2		-338,0344	-3,872E-17	21-1
21	9	ENVELOPE_ ULS	Max	331,9293	1,939E-13	21-1
21	8	ENVELOPE_ ULS	Max	-335,7411	-3,872E-17	21-1
21	9	ENVELOPE_ ULS	Min	243,1819	1,518E-17	21-1
21	8	ENVELOPE_ ULS	Min	-338,0344	-1,717E-13	21-1
22	8	USL1		335,7411	1,822E-13	22-1
22	7	USL1		-224,8605	-1,672E-13	22-1
22	8	ULS2		338,0344	3,872E-17	22-1
22	7	ULS2		-308,2010	-6,542E-17	22-1
22	8	ENVELOPE_ ULS	Max	338,0344	1,822E-13	22-1
22	7	ENVELOPE_ ULS	Max	-224,8605	-6,542E-17	22-1
22	8	ENVELOPE_ ULS	Min	335,7411	3,872E-17	22-1
22	7	ENVELOPE_ ULS	Min	-308,2010	-1,672E-13	22-1
23	7	USL1		224,8605	2,066E-13	23-1
23	6	USL1		-49,5397	-1,680E-13	23-1
23	7	ULS2		308,2010	6,542E-17	23-1
23	6	ULS2		-186,4025	-9,480E-17	23-1
23	7	ENVELOPE_ ULS	Max	308,2010	2,066E-13	23-1
23	6	ENVELOPE_ ULS	Max	-49,5397	-9,480E-17	23-1
23	7	ENVELOPE_ ULS	Min	224,8605	6,542E-17	23-1

Table: Element Joint Forces - Frames, Part 2 of 2

Frame	Joint	OutputCase	StepType	M2	M3	FrameElem
				KN-m	KN-m	
23	6	ENVELOPE_ ULS	Min	-186,4025	-1,680E-13	23-1
24	6	USL1		49,5397	1,455E-13	24-1
24	5	USL1		146,3274	-7,191E-14	24-1
24	6	ULS2		186,4025	9,480E-17	24-1
24	5	ULS2		-10,8248	-1,270E-16	24-1
24	6	ENVELOPE_ ULS	Max	186,4025	1,455E-13	24-1
24	5	ENVELOPE_ ULS	Max	146,3274	-1,270E-16	24-1
24	6	ENVELOPE_ ULS	Min	49,5397	9,480E-17	24-1
24	5	ENVELOPE_ ULS	Min	-10,8248	-7,191E-14	24-1
25	5	USL1		-146,3274	6,000E-14	25-1
25	4	USL1		282,3641	2,391E-14	25-1
25	5	ULS2		10,8248	1,270E-16	25-1
25	4	ULS2		142,5039	-1,580E-16	25-1
25	5	ENVELOPE_ ULS	Max	10,8248	6,000E-14	25-1
25	4	ENVELOPE_ ULS	Max	282,3641	2,391E-14	25-1
25	5	ENVELOPE_ ULS	Min	-146,3274	1,270E-16	25-1
25	4	ENVELOPE_ ULS	Min	142,5039	-1,580E-16	25-1
26	35	USL1		-111,0554	4,434E-14	26-1
26	27	USL1		56,2967	-4,434E-14	26-1
26	35	ULS2		-191,7764	1,704E-15	26-1
26	27	ULS2		116,2901	-1,704E-15	26-1
26	35	ENVELOPE_ ULS	Max	-111,0554	4,434E-14	26-1
26	27	ENVELOPE_ ULS	Max	116,2901	-1,704E-15	26-1
26	35	ENVELOPE_ ULS	Min	-191,7764	1,704E-15	26-1
26	27	ENVELOPE_ ULS	Min	56,2967	-4,434E-14	26-1
27	4	USL1		-282,3641	-3,960E-14	27-1
27	3	USL1		338,3267	9,131E-14	27-1
27	4	ULS2		-142,5039	1,580E-16	27-1
27	3	ULS2		250,6963	-1,875E-16	27-1
27	4	ENVELOPE_ ULS	Max	-142,5039	1,580E-16	27-1
27	3	ENVELOPE_ ULS	Max	338,3267	9,131E-14	27-1
27	4	ENVELOPE_ ULS	Min	-282,3641	-3,960E-14	27-1
27	3	ENVELOPE_ ULS	Min	250,6963	-1,875E-16	27-1
28	3	USL1		-338,3267	-9,808E-14	28-1
28	2	USL1		284,3396	1,320E-13	28-1
28	3	ULS2		-250,6963	1,875E-16	28-1
28	2	ULS2		277,3161	-2,144E-16	28-1
28	3	ENVELOPE_ ULS	Max	-250,6963	1,875E-16	28-1
28	2	ENVELOPE_ ULS	Max	284,3396	1,320E-13	28-1
28	3	ENVELOPE_ ULS	Min	-338,3267	-9,808E-14	28-1
28	2	ENVELOPE_ ULS	Min	277,3161	-2,144E-16	28-1
29	2	USL1		-284,3396	-1,208E-13	29-1

Table: Element Joint Forces - Frames, Part 2 of 2

Frame	Joint	OutputCase	StepType	M2	M3	FrameElem
				KN-m	KN-m	
29	1	USL1		85,2910	1,017E-13	29-1
29	2	ULS2		-277,3161	2,144E-16	29-1
29	1	ULS2		175,9263	-2,376E-16	29-1
29	2	ENVELOPE_ ULS	Max	-277,3161	2,144E-16	29-1
29	1	ENVELOPE_ ULS	Max	175,9263	1,017E-13	29-1
29	2	ENVELOPE_ ULS	Min	-284,3396	-1,208E-13	29-1
29	1	ENVELOPE_ ULS	Min	85,2910	-2,376E-16	29-1
30	1	USL1		-3,2507	-4,238E-14	30-1
30	34	USL1		48,5422	3,304E-14	30-1
30	1	ULS2		-61,5156	-1,041E-15	30-1
30	34	ULS2		85,1268	5,788E-16	30-1
30	1	ENVELOPE_ ULS	Max	-3,2507	-1,041E-15	30-1
30	34	ENVELOPE_ ULS	Max	85,1268	3,304E-14	30-1
30	1	ENVELOPE_ ULS	Min	-61,5156	-4,238E-14	30-1
30	34	ENVELOPE_ ULS	Min	48,5422	5,788E-16	30-1
31	34	USL1		-48,5422	-3,304E-14	31-1
31	10	USL1		130,1488	3,968E-14	31-1
31	34	ULS2		-85,1268	-5,788E-16	31-1
31	10	ULS2		97,6877	1,164E-16	31-1
31	34	ENVELOPE_ ULS	Max	-48,5422	-5,788E-16	31-1
31	10	ENVELOPE_ ULS	Max	130,1488	3,968E-14	31-1
31	34	ENVELOPE_ ULS	Min	-85,1268	-3,304E-14	31-1
31	10	ENVELOPE_ ULS	Min	97,6877	1,164E-16	31-1
32	10	USL1		-130,1488	-2,721E-14	32-1
32	23	USL1		-18,4444	2,721E-14	32-1
32	10	ULS2		-97,6877	-1,164E-16	32-1
32	23	ULS2		41,4717	1,164E-16	32-1
32	10	ENVELOPE_ ULS	Max	-97,6877	-1,164E-16	32-1
32	23	ENVELOPE_ ULS	Max	41,4717	2,721E-14	32-1
32	10	ENVELOPE_ ULS	Min	-130,1488	-2,721E-14	32-1
32	23	ENVELOPE_ ULS	Min	-18,4444	1,164E-16	32-1
34	24	USL1		603,2894	-9,386E-14	34-1
34	25	USL1		-1142,8743	9,031E-14	34-1
34	24	ULS2		424,8125	2,851E-16	34-1
34	25	ULS2		-931,8655	-2,851E-16	34-1
34	24	ENVELOPE_ ULS	Max	603,2894	2,851E-16	34-1
34	25	ENVELOPE_ ULS	Max	-931,8655	9,031E-14	34-1
34	24	ENVELOPE_ ULS	Min	424,8125	-9,386E-14	34-1
34	25	ENVELOPE_ ULS	Min	-1142,8743	-2,851E-16	34-1
35	25	USL1		1142,8743	-9,564E-14	35-1
35	26	USL1		-1157,0973	9,564E-14	35-1
35	25	ULS2		931,8655	2,851E-16	35-1

Table: Element Joint Forces - Frames, Part 2 of 2

Frame	Joint	OutputCase	StepType	M2	M3	FrameElem
				KN-m	KN-m	
35	26	ULS2		-963,2897	-2,851E-16	35-1
35	25	ENVELOPE_ ULS	Max	1142,8743	2,851E-16	35-1
35	26	ENVELOPE_ ULS	Max	-963,2897	9,564E-14	35-1
35	25	ENVELOPE_ ULS	Min	931,8655	-9,564E-14	35-1
35	26	ENVELOPE_ ULS	Min	-1157,0973	-2,851E-16	35-1
36	26	USL1		1157,0973	-9,209E-14	36-1
36	11	USL1		-679,8491	9,209E-14	36-1
36	26	ULS2		963,2897	2,851E-16	36-1
36	11	ULS2		-545,4095	-2,851E-16	36-1
36	26	ENVELOPE_ ULS	Max	1157,0973	2,851E-16	36-1
36	11	ENVELOPE_ ULS	Max	-545,4095	9,209E-14	36-1
36	26	ENVELOPE_ ULS	Min	963,2897	-9,209E-14	36-1
36	11	ENVELOPE_ ULS	Min	-679,8491	-2,851E-16	36-1
37	23	USL1		18,4444	-2,765E-14	37-1
37	36	USL1		-72,1858	2,765E-14	37-1
37	23	ULS2		-41,4717	-1,164E-16	37-1
37	36	ULS2		8,8394	1,164E-16	37-1
37	23	ENVELOPE_ ULS	Max	18,4444	-1,164E-16	37-1
37	36	ENVELOPE_ ULS	Max	8,8394	2,765E-14	37-1
37	23	ENVELOPE_ ULS	Min	-41,4717	-2,765E-14	37-1
37	36	ENVELOPE_ ULS	Min	-72,1858	1,164E-16	37-1
38	36	USL1		60,1397	-8,853E-14	38-1
38	24	USL1		-603,2894	8,853E-14	38-1
38	36	ULS2		-80,8739	2,851E-16	38-1
38	24	ULS2		-424,8125	-2,851E-16	38-1
38	36	ENVELOPE_ ULS	Max	60,1397	2,851E-16	38-1
38	24	ENVELOPE_ ULS	Max	-424,8125	8,853E-14	38-1
38	36	ENVELOPE_ ULS	Min	-80,8739	-8,853E-14	38-1
38	24	ENVELOPE_ ULS	Min	-603,2894	-2,851E-16	38-1
39	1	USL1		-82,0403	-7,150E-14	39-1
39	36	USL1		12,0461	5,999E-14	39-1
39	1	ULS2		-114,4108	1,279E-15	39-1
39	36	ULS2		72,0345	-4,015E-16	39-1
39	1	ENVELOPE_ ULS	Max	-82,0403	1,279E-15	39-1
39	36	ENVELOPE_ ULS	Max	72,0345	5,999E-14	39-1
39	1	ENVELOPE_ ULS	Min	-114,4108	-7,150E-14	39-1
39	36	ENVELOPE_ ULS	Min	12,0461	-4,015E-16	39-1
40	9	USL1		-165,2510	-1,093E-13	40-1
40	35	USL1		-167,6817	7,598E-14	40-1
40	9	ULS2		-134,3066	-1,245E-15	40-1
40	35	ULS2		-228,7925	-1,735E-15	40-1
40	9	ENVELOPE_ ULS	Max	-134,3066	-1,245E-15	40-1

Table: Element Joint Forces - Frames, Part 2 of 2

Frame	Joint	OutputCase	StepType	M2 KN-m	M3 KN-m	FrameElem
40	35	ENVELOPE_ ULS	Max	-167,6817	7,598E-14	40-1
40	9	ENVELOPE_ ULS	Min	-165,2510	-1,093E-13	40-1
40	35	ENVELOPE_ ULS	Min	-228,7925	-1,735E-15	40-1

Table: Frame Loads - Distributed, Part 1 of 3

Table: Frame Loads - Distributed, Part 1 of 3

Frame	LoadPat	CoordSys	Type	Dir	DistType	RelDistA
2	HYDROSTATIC	Local	Force	2	RelDist	0,0000
2	EARTH	GLOBAL	Force	Gravity	RelDist	0,0000
3	HYDROSTATIC	Local	Force	2	RelDist	0,0000
3	EARTH	GLOBAL	Force	Gravity	RelDist	0,0000
4	HYDROSTATIC	Local	Force	2	RelDist	0,0000
4	EARTH	GLOBAL	Force	Gravity	RelDist	0,0000
5	HYDROSTATIC	Local	Force	2	RelDist	0,0000
5	EARTH	GLOBAL	Force	Gravity	RelDist	0,0000
6	HYDROSTATIC	Local	Force	2	RelDist	0,0000
6	EARTH	GLOBAL	Force	Gravity	RelDist	0,0000
7	HYDROSTATIC	Local	Force	2	RelDist	0,0000
7	EARTH	GLOBAL	Force	Gravity	RelDist	0,0000
8	HYDROSTATIC	Local	Force	2	RelDist	0,0000
8	EARTH	GLOBAL	Force	Gravity	RelDist	0,0000
8	EARTH_PRESSURE DX	GLOBAL	Force	X	RelDist	0,0000
8	DINAMIC EARTH PRESSURE	GLOBAL	Force	X	RelDist	0,0000
9	HYDROSTATIC	Local	Force	2	RelDist	0,0000
9	EARTH	GLOBAL	Force	Gravity	RelDist	0,0000
9	EARTH_PRESSURE DX	GLOBAL	Force	X	RelDist	0,0000
9	DINAMIC EARTH PRESSURE	GLOBAL	Force	X	RelDist	0,0000
10	HYDROSTATIC	Local	Force	2	RelDist	0,0000
10	EARTH	GLOBAL	Force	Gravity	RelDist	0,0000
10	EARTH_PRESSURE DX	GLOBAL	Force	X	RelDist	0,0000
10	DINAMIC EARTH PRESSURE	GLOBAL	Force	X	RelDist	0,0000
11	HYDROSTATIC	Local	Force	2	RelDist	0,0000
11	EARTH	GLOBAL	Force	Gravity	RelDist	0,0000
11	EARTH_PRESSURE DX	GLOBAL	Force	X	RelDist	0,0000
11	DINAMIC EARTH PRESSURE	GLOBAL	Force	X	RelDist	0,0000
12	HYDROSTATIC	Local	Force	2	RelDist	0,0000
12	EARTH	GLOBAL	Force	Gravity	RelDist	0,0000
12	EARTH_PRESSURE DX	GLOBAL	Force	X	RelDist	0,0000
12	DINAMIC EARTH PRESSURE	GLOBAL	Force	X	RelDist	0,0000
13	HYDROSTATIC	Local	Force	2	RelDist	0,0000
13	EARTH	GLOBAL	Force	Gravity	RelDist	0,0000
13	EARTH_PRESSURE DX	GLOBAL	Force	X	RelDist	0,0000
13	DINAMIC EARTH PRESSURE	GLOBAL	Force	X	RelDist	0,0000
14	HYDROSTATIC	Local	Force	2	RelDist	0,0000

Table: Frame Loads - Distributed, Part 1 of 3

Frame	LoadPat	CoordSys	Type	Dir	DistType	RelDistA
14	EARTH_PRESSURE DX	GLOBAL	Force	X	RelDist	0,0000
14	DINAMIC EARTH PRESSURE	GLOBAL	Force	X	RelDist	0,0000
15	HYDROSTATIC	Local	Force	2	RelDist	0,0000
15	EARTH_PRESSURE DX	GLOBAL	Force	X	RelDist	0,0000
15	DINAMIC EARTH PRESSURE	GLOBAL	Force	X	RelDist	0,0000
16	HYDROSTATIC	Local	Force	2	RelDist	0,0000
16	EARTH_PRESSURE DX	GLOBAL	Force	X	RelDist	0,0000
16	DINAMIC EARTH PRESSURE	GLOBAL	Force	X	RelDist	0,0000
18	HYDROSTATIC	Local	Force	2	RelDist	0,0000
18	EARTH_PRESSURE DX	GLOBAL	Force	X	RelDist	0,0000
18	DINAMIC EARTH PRESSURE	GLOBAL	Force	X	RelDist	0,0000
19	HYDROSTATIC	Local	Force	2	RelDist	0,0000
20	HYDROSTATIC	Local	Force	2	RelDist	0,0000
21	HYDROSTATIC	Local	Force	2	RelDist	0,0000
21	EARTH_PRESSURE DX	GLOBAL	Force	X	RelDist	0,0000
21	DINAMIC EARTH PRESSURE	GLOBAL	Force	X	RelDist	0,0000
22	HYDROSTATIC	Local	Force	2	RelDist	0,0000
22	EARTH_PRESSURE DX	GLOBAL	Force	X	RelDist	0,0000
22	DINAMIC EARTH PRESSURE	GLOBAL	Force	X	RelDist	0,0000
23	HYDROSTATIC	Local	Force	2	RelDist	0,0000
23	EARTH_PRESSURE DX	GLOBAL	Force	X	RelDist	0,0000
23	DINAMIC EARTH PRESSURE	GLOBAL	Force	X	RelDist	0,0000
24	HYDROSTATIC	Local	Force	2	RelDist	0,0000
24	EARTH_PRESSURE DX	GLOBAL	Force	X	RelDist	0,0000
24	DINAMIC EARTH PRESSURE	GLOBAL	Force	X	RelDist	0,0000
25	HYDROSTATIC	Local	Force	2	RelDist	0,0000
27	HYDROSTATIC	Local	Force	2	RelDist	0,0000
28	HYDROSTATIC	Local	Force	2	RelDist	0,0000
29	HYDROSTATIC	Local	Force	2	RelDist	0,0000
30	HYDROSTATIC	Local	Force	2	RelDist	0,0000
31	HYDROSTATIC	Local	Force	2	RelDist	0,0000
32	HYDROSTATIC	Local	Force	2	RelDist	0,0000
34	HYDROSTATIC	Local	Force	2	RelDist	0,0000
35	HYDROSTATIC	Local	Force	2	RelDist	0,0000
36	HYDROSTATIC	Local	Force	2	RelDist	0,0000
1	EARTH_PRESSURE DX	GLOBAL	Force	X	RelDist	0,0000
1	HYDROSTATIC	Local	Force	2	RelDist	0,0000
1	DINAMIC EARTH PRESSURE	GLOBAL	Force	X	RelDist	0,0000
26	EARTH_PRESSURE DX	GLOBAL	Force	X	RelDist	0,0000
26	HYDROSTATIC	Local	Force	2	RelDist	0,0000
26	DINAMIC EARTH PRESSURE	GLOBAL	Force	X	RelDist	0,0000
37	HYDROSTATIC	Local	Force	2	RelDist	0,0000

Table: Frame Loads - Distributed, Part 1 of 3

Frame	LoadPat	CoordSys	Type	Dir	DistType	RelDistA
38	HYDROSTATIC	Local	Force	2	RelDist	0,0000

Table: Frame Loads - Distributed, Part 2 of 3

Table: Frame Loads - Distributed, Part 2 of 3

Frame	LoadPat	RelDistB	AbsDistA m	AbsDistB m	FOverLA KN/m	FOverLB KN/m
2	HYDROSTATIC	1,0000	0,00000	1,15723	-38,20	-31,00
2	EARTH	1,0000	0,00000	1,15723	51,50	51,50
3	HYDROSTATIC	1,0000	0,00000	1,02464	-31,00	-24,50
3	EARTH	1,0000	0,00000	1,02464	47,40	47,40
4	HYDROSTATIC	1,0000	0,00000	0,98945	-24,50	-18,60
4	EARTH	1,0000	0,00000	0,98945	39,70	39,70
5	HYDROSTATIC	1,0000	0,00000	0,98804	-18,60	-14,00
5	EARTH	1,0000	0,00000	0,98804	32,70	32,70
6	HYDROSTATIC	1,0000	0,00000	0,98763	-14,00	-11,10
6	EARTH	1,0000	0,00000	0,98763	26,90	26,90
7	HYDROSTATIC	1,0000	0,00000	1,04617	-11,10	-10,00
7	EARTH	1,0000	0,00000	1,04617	22,80	22,80
8	HYDROSTATIC	1,0000	0,00000	1,08329	-10,00	-11,10
8	EARTH	1,0000	0,00000	1,08329	22,80	22,80
8	EARTH_PRESSURE DX	1,0000	0,00000	1,08329	-27,00	-28,10
8	DINAMIC EARTH PRESSURE	1,0000	0,00000	1,08329	-24,00	-24,00
9	HYDROSTATIC	1,0000	0,00000	0,98504	-11,10	-14,00
9	EARTH	1,0000	0,00000	0,98504	26,90	26,90
9	EARTH_PRESSURE DX	1,0000	0,00000	0,98504	-28,10	-31,10
9	DINAMIC EARTH PRESSURE	1,0000	0,00000	0,98504	-24,00	-24,00
10	HYDROSTATIC	1,0000	0,00000	0,98394	-14,00	-18,60
10	EARTH	1,0000	0,00000	0,98394	32,70	32,70
10	EARTH_PRESSURE DX	1,0000	0,00000	0,98394	-31,10	-35,70
10	DINAMIC EARTH PRESSURE	1,0000	0,00000	0,98394	-24,00	-24,00
11	HYDROSTATIC	1,0000	0,00000	0,98416	-18,60	-24,50
11	EARTH	1,0000	0,00000	0,98416	39,70	39,70
11	EARTH_PRESSURE DX	1,0000	0,00000	0,98416	-35,70	-41,70
11	DINAMIC EARTH PRESSURE	1,0000	0,00000	0,98416	-24,00	-24,00
12	HYDROSTATIC	1,0000	0,00000	1,01876	-24,50	-31,00
12	EARTH	1,0000	0,00000	1,01876	47,40	47,40
12	EARTH_PRESSURE DX	1,0000	0,00000	1,01876	-41,70	-48,10
12	DINAMIC EARTH PRESSURE	1,0000	0,00000	1,01876	-24,00	-24,00
13	HYDROSTATIC	1,0000	0,00000	1,13787	-31,00	-38,20
13	EARTH	1,0000	0,00000	1,13787	51,50	51,50
13	EARTH_PRESSURE DX	1,0000	0,00000	1,13787	-48,10	-55,40
13	DINAMIC EARTH PRESSURE	1,0000	0,00000	1,13787	-24,00	-24,00
14	HYDROSTATIC	1,0000	0,00000	0,95249	-38,20	-46,70
14	EARTH_PRESSURE DX	1,0000	0,00000	0,95249	-55,40	-64,00
14	DINAMIC EARTH PRESSURE	1,0000	0,00000	0,95249	-24,00	-24,00

Table: Frame Loads - Distributed, Part 2 of 3

Frame	LoadPat	RelDistB	AbsDistA m	AbsDistB m	FOverLA KN/m	FOverLB KN/m
15	HYDROSTATIC	1,0000	0,00000	0,95249	-46,70	-55,20
15	EARTH_PRESSURE DX	1,0000	0,00000	0,95249	-64,00	-72,60
15	DINAMIC EARTH PRESSURE	1,0000	0,00000	0,95249	-24,00	-24,00
16	HYDROSTATIC	1,0000	0,00000	0,95249	-55,20	-63,80
16	EARTH_PRESSURE DX	1,0000	0,00000	0,95249	-72,60	-81,10
16	DINAMIC EARTH PRESSURE	1,0000	0,00000	0,95249	-24,00	-24,00
18	HYDROSTATIC	1,0000	0,00000	0,95249	-72,30	-80,80
18	EARTH_PRESSURE DX	1,0000	0,00000	0,95249	-89,70	-98,30
18	DINAMIC EARTH PRESSURE	1,0000	0,00000	0,95249	-24,00	-24,00
19	HYDROSTATIC	1,0000	0,00000	0,76564	-80,80	-80,80
20	HYDROSTATIC	1,0000	0,00000	0,72730	-80,80	-80,80
21	HYDROSTATIC	1,0000	0,00000	1,00122	-80,80	-86,60
21	EARTH_PRESSURE DX	1,0000	0,00000	1,00122	-98,30	-104,20
21	DINAMIC EARTH PRESSURE	1,0000	0,00000	1,00122	-24,00	-24,00
22	HYDROSTATIC	1,0000	0,00000	0,99802	-86,60	-91,20
22	EARTH_PRESSURE DX	1,0000	0,00000	0,99802	-104,20	-108,80
22	DINAMIC EARTH PRESSURE	1,0000	0,00000	0,99802	-24,00	-24,00
23	HYDROSTATIC	1,0000	0,00000	0,99844	-91,20	-94,00
23	EARTH_PRESSURE DX	1,0000	0,00000	0,99844	-108,80	-111,60
23	DINAMIC EARTH PRESSURE	1,0000	0,00000	0,99844	-24,00	-24,00
24	HYDROSTATIC	1,0000	0,00000	1,04339	-94,00	-95,00
24	EARTH_PRESSURE DX	1,0000	0,00000	1,04339	-111,60	-114,50
24	DINAMIC EARTH PRESSURE	1,0000	0,00000	1,04339	-24,00	-24,00
25	HYDROSTATIC	1,0000	0,00000	1,00615	-95,00	-94,00
27	HYDROSTATIC	1,0000	0,00000	1,00094	-94,00	-91,20
28	HYDROSTATIC	1,0000	0,00000	1,00204	-91,20	-86,60
29	HYDROSTATIC	1,0000	0,00000	1,00321	-86,60	-80,80
30	HYDROSTATIC	1,0000	0,00000	0,76564	-80,80	-80,80
31	HYDROSTATIC	1,0000	0,00000	0,76564	-80,80	-80,80
32	HYDROSTATIC	1,0000	0,00000	0,95249	-80,80	-72,30
34	HYDROSTATIC	1,0000	0,00000	0,95249	-63,80	-55,20
35	HYDROSTATIC	1,0000	0,00000	0,95249	-55,20	-46,70
36	HYDROSTATIC	1,0000	0,00000	0,95249	-46,70	-38,20
1	EARTH_PRESSURE DX	1,0000	0,00000	0,47625	-81,10	-85,40
1	HYDROSTATIC	1,0000	0,00000	0,47625	-63,80	-68,05
1	DINAMIC EARTH PRESSURE	1,0000	0,00000	0,47625	-24,00	-24,00
26	EARTH_PRESSURE DX	1,0000	0,00000	0,47625	-85,40	-89,70
26	HYDROSTATIC	1,0000	0,00000	0,47625	-68,05	-72,30
26	DINAMIC EARTH PRESSURE	1,0000	0,00000	0,47625	-24,00	-24,00
37	HYDROSTATIC	1,0000	0,00000	0,47625	-72,30	-68,05
38	HYDROSTATIC	1,0000	0,00000	0,47625	-68,05	-63,80

Table: Frame Loads - Distributed, Part 3 of 3

Table: Frame Loads - Distributed, Part 3 of 3

Frame	LoadPat	GUID
2	HYDROSTATIC	
2	EARTH	
3	HYDROSTATIC	
3	EARTH	
4	HYDROSTATIC	
4	EARTH	
5	HYDROSTATIC	
5	EARTH	
6	HYDROSTATIC	
6	EARTH	
7	HYDROSTATIC	
7	EARTH	
8	HYDROSTATIC	
8	EARTH	
8	EARTH_PRESSURE DX	
8	DINAMIC EARTH PRESSURE	
9	HYDROSTATIC	
9	EARTH	
9	EARTH_PRESSURE DX	
9	DINAMIC EARTH PRESSURE	
10	HYDROSTATIC	
10	EARTH	
10	EARTH_PRESSURE DX	
10	DINAMIC EARTH PRESSURE	
11	HYDROSTATIC	
11	EARTH	
11	EARTH_PRESSURE DX	
11	DINAMIC EARTH PRESSURE	
12	HYDROSTATIC	
12	EARTH	
12	EARTH_PRESSURE DX	
12	DINAMIC EARTH PRESSURE	
13	HYDROSTATIC	
13	EARTH	
13	EARTH_PRESSURE DX	
13	DINAMIC EARTH PRESSURE	
14	HYDROSTATIC	
14	EARTH_PRESSURE DX	
14	DINAMIC EARTH PRESSURE	
15	HYDROSTATIC	
15	EARTH_PRESSURE DX	
15	DINAMIC EARTH PRESSURE	
16	HYDROSTATIC	

Table: Frame Loads - Distributed, Part 3 of 3

Frame	LoadPat	GUID
16	EARTH_PRESSURE DX	
16	DINAMIC EARTH PRESSURE	
18	HYDROSTATIC	
18	EARTH_PRESSURE DX	
18	DINAMIC EARTH PRESSURE	
19	HYDROSTATIC	
20	HYDROSTATIC	
21	HYDROSTATIC	
21	EARTH_PRESSURE DX	
21	DINAMIC EARTH PRESSURE	
22	HYDROSTATIC	
22	EARTH_PRESSURE DX	
22	DINAMIC EARTH PRESSURE	
23	HYDROSTATIC	
23	EARTH_PRESSURE DX	
23	DINAMIC EARTH PRESSURE	
24	HYDROSTATIC	
24	EARTH_PRESSURE DX	
24	DINAMIC EARTH PRESSURE	
25	HYDROSTATIC	
27	HYDROSTATIC	
28	HYDROSTATIC	
29	HYDROSTATIC	
30	HYDROSTATIC	
31	HYDROSTATIC	
32	HYDROSTATIC	
34	HYDROSTATIC	
35	HYDROSTATIC	
36	HYDROSTATIC	
1	EARTH_PRESSURE DX	
1	HYDROSTATIC	
1	DINAMIC EARTH PRESSURE	
26	EARTH_PRESSURE DX	
26	HYDROSTATIC	
26	DINAMIC EARTH PRESSURE	
37	HYDROSTATIC	
38	HYDROSTATIC	

Table: Joint Spring Assignments 1 - Uncoupled

Table: Joint Spring Assignments 1 - Uncoupled

Joint	CoordSys	U1	U2	U3	R1	R2	R3
		KN/m	KN/m	KN/m	KN-m/rad	KN-m/rad	KN-m/rad
1	Local	0,00	0,00	6787,00	0,0000	0,0000	0,0000
2	Local	0,00	0,00	6787,00	0,0000	0,0000	0,0000

Table: Joint Spring Assignments 1 - Uncoupled

Joint	CoordSys	U1	U2	U3	R1	R2	R3
		KN/m	KN/m	KN/m	KN-m/rad	KN-m/rad	KN-m/rad
3	Local	0,00	0,00	6787,00	0,0000	0,0000	0,0000
4	Local	0,00	0,00	6787,00	0,0000	0,0000	0,0000
5	Local	0,00	0,00	6787,00	0,0000	0,0000	0,0000
6	Local	0,00	0,00	6787,00	0,0000	0,0000	0,0000
7	Local	0,00	0,00	6787,00	0,0000	0,0000	0,0000
8	Local	0,00	0,00	6787,00	0,0000	0,0000	0,0000
9	Local	0,00	0,00	6787,00	0,0000	0,0000	0,0000
10	Local	0,00	0,00	6787,00	0,0000	0,0000	0,0000
11	Local	19780,00	0,00	0,00	0,0000	0,0000	0,0000
24	Local	19780,00	0,00	0,00	0,0000	0,0000	0,0000
25	Local	19780,00	0,00	0,00	0,0000	0,0000	0,0000
26	Local	19780,00	0,00	0,00	0,0000	0,0000	0,0000
32	Local	0,00	0,00	6787,00	0,0000	0,0000	0,0000

Table: Load Pattern Definitions

Table: Load Pattern Definitions

LoadPat	DesignType	SelfWtMult	AutoLoad	GUID	Notes
DEAD	DEAD	1,000000			
EARTH	DEAD	0,000000			
EARTH_PRESSURE DX	DEAD	0,000000			
HYDROSTATIC	DEAD	0,000000			
DINAMIC EARTH PRESSURE	DEAD	0,000000			
INERTIA	DEAD	0,000000			