

STEEL RIBS TYPE 2 IPE 180
NERVURI DIN OTEL TIP 2 IPE 180
Scale/Scara 1:20

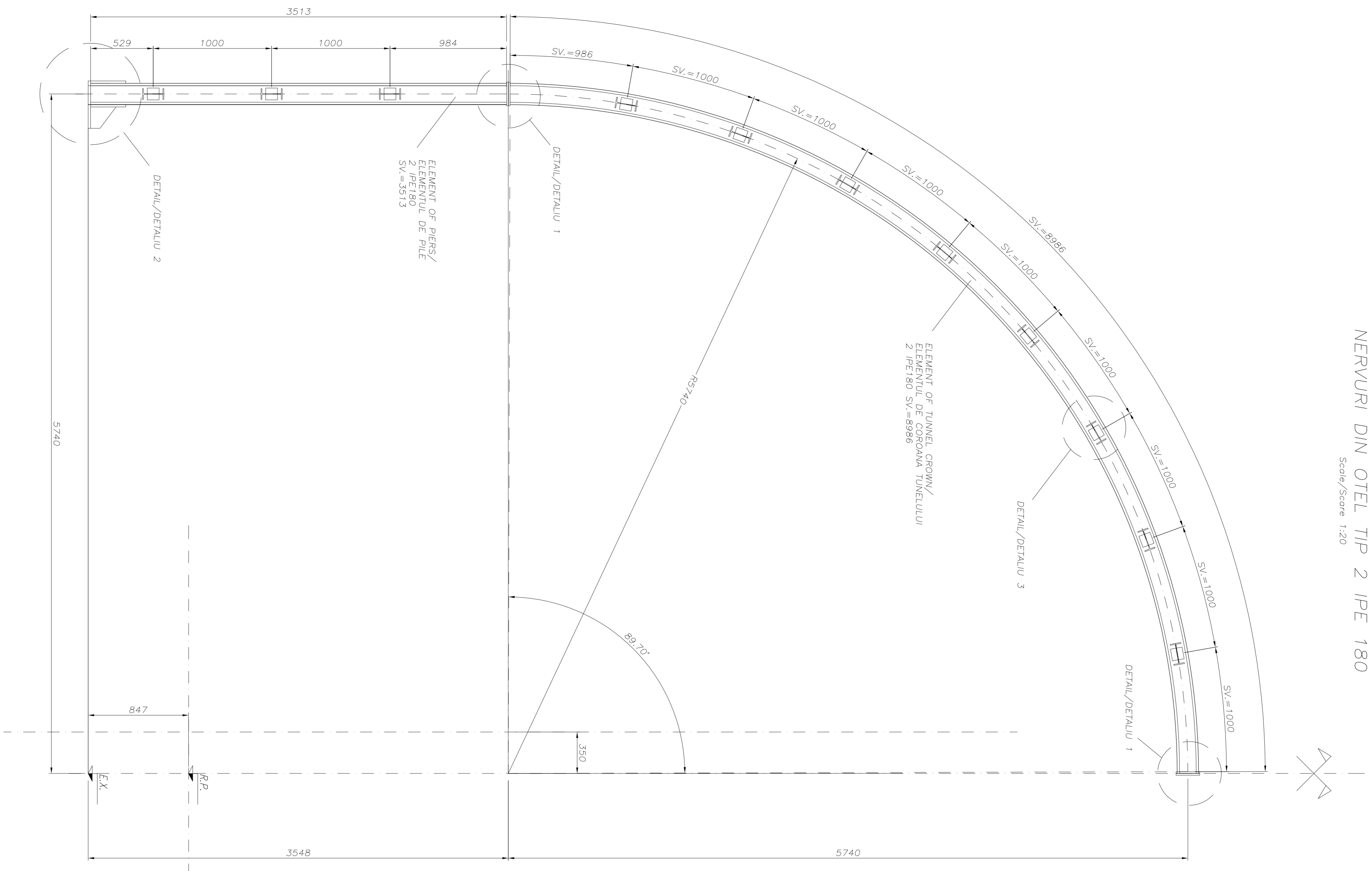

DETAIL "1"
DETAILUL "1"
Scale/Scara 1:5

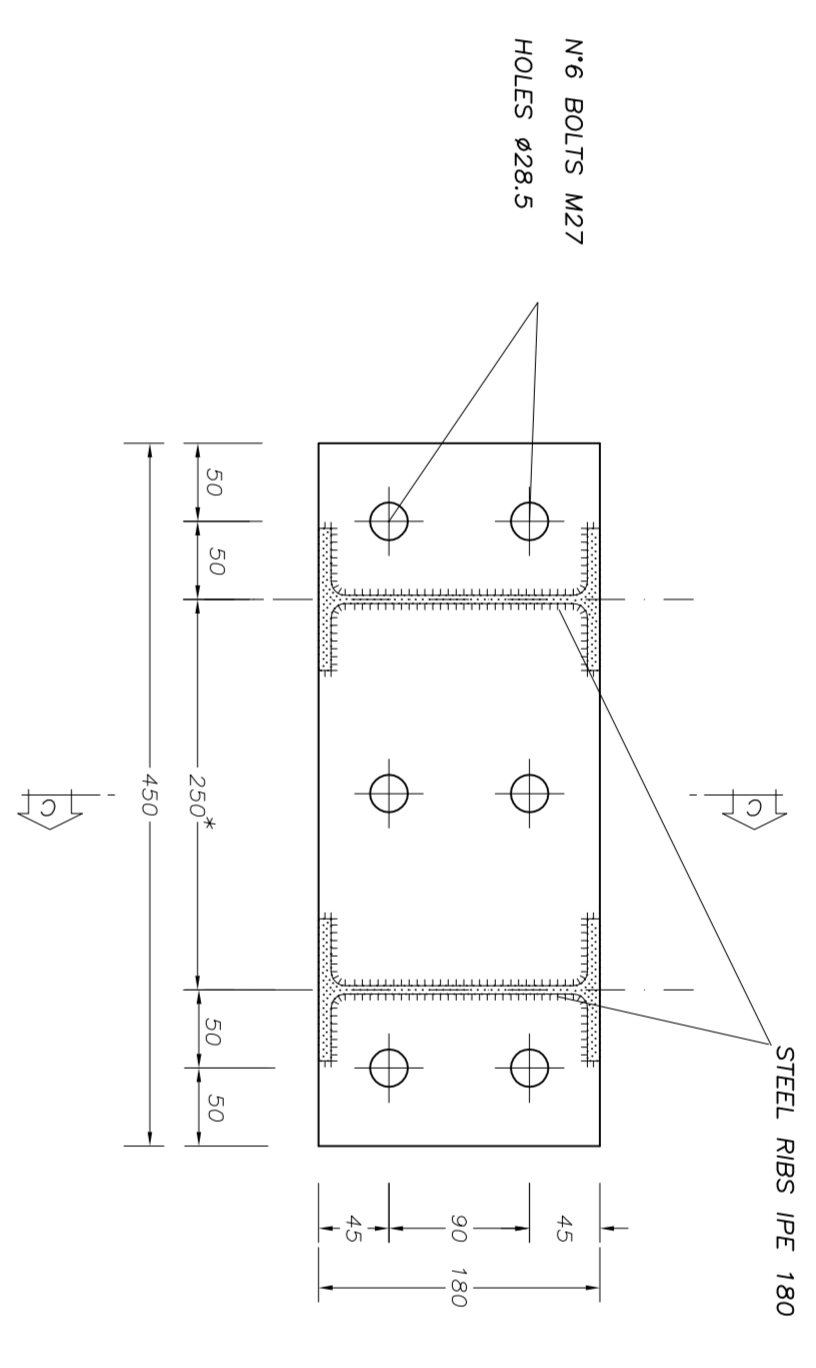

SECTION A-A
SECTIUNI A-A
Scale/Scara 1:5

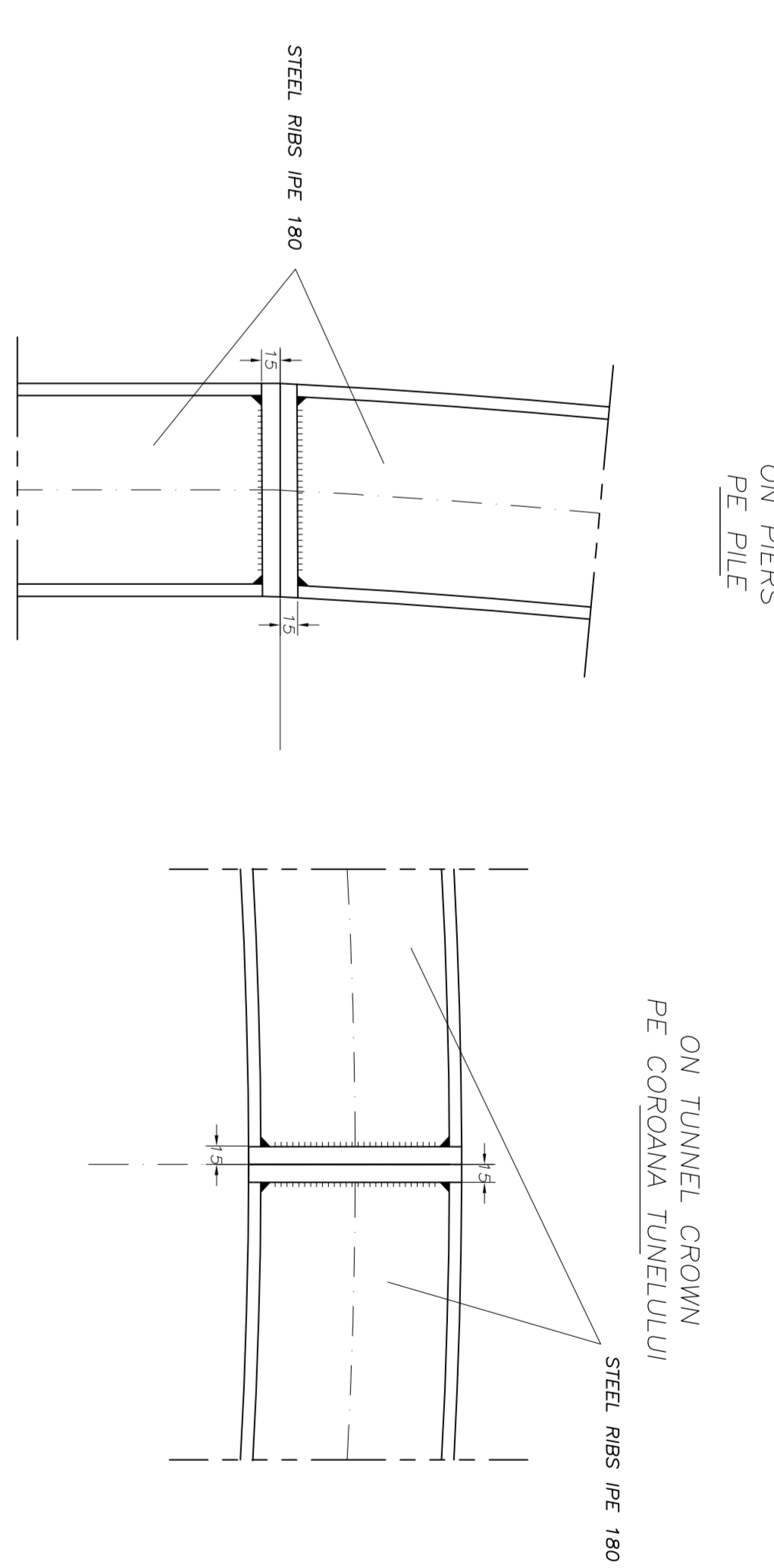

DETAIL "2"
DETAILUL "2"
Scale/Scara 1:5

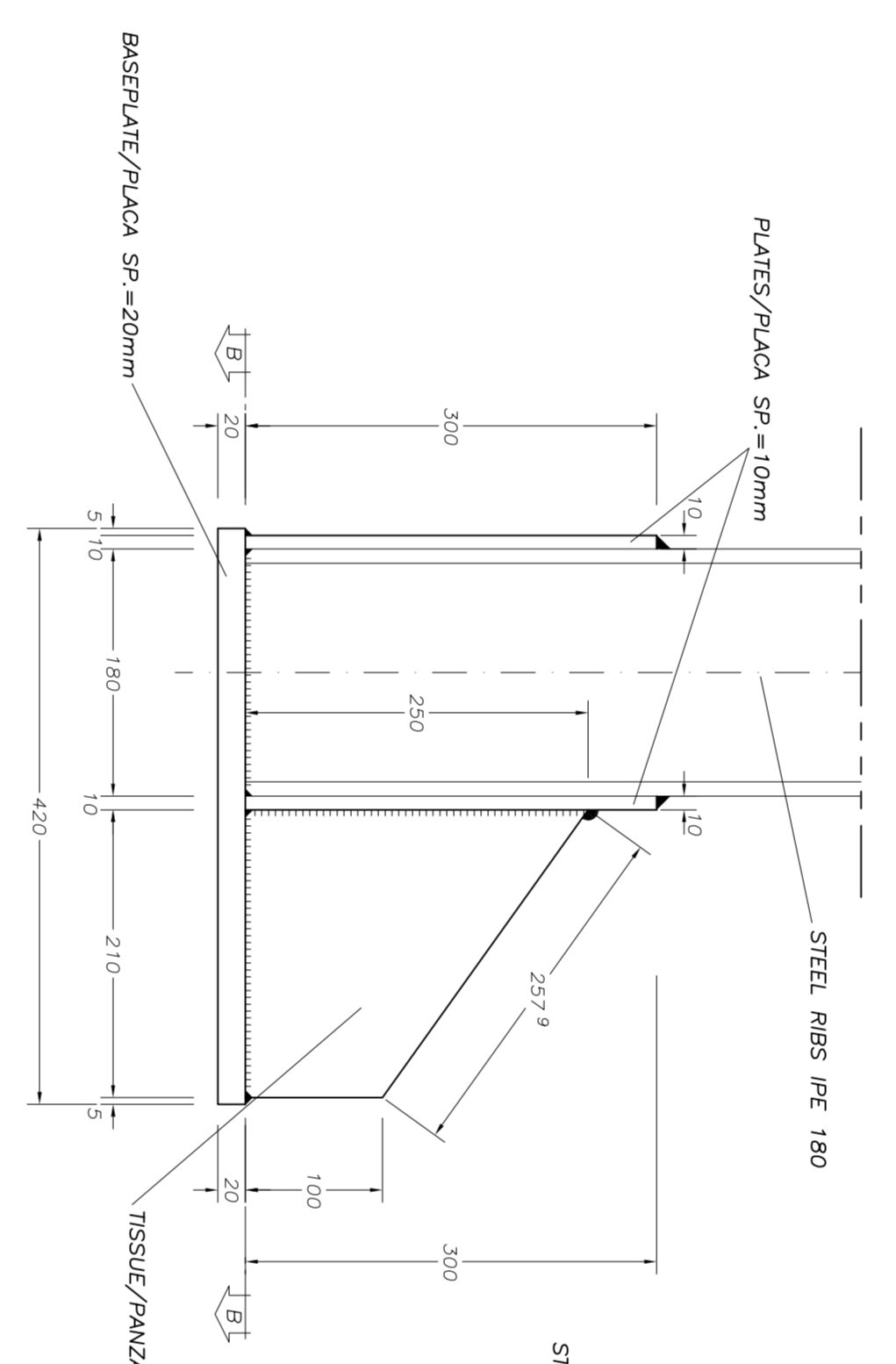

SECTION B-B
SECTIUNI B-B
Scale/Scara 1:5

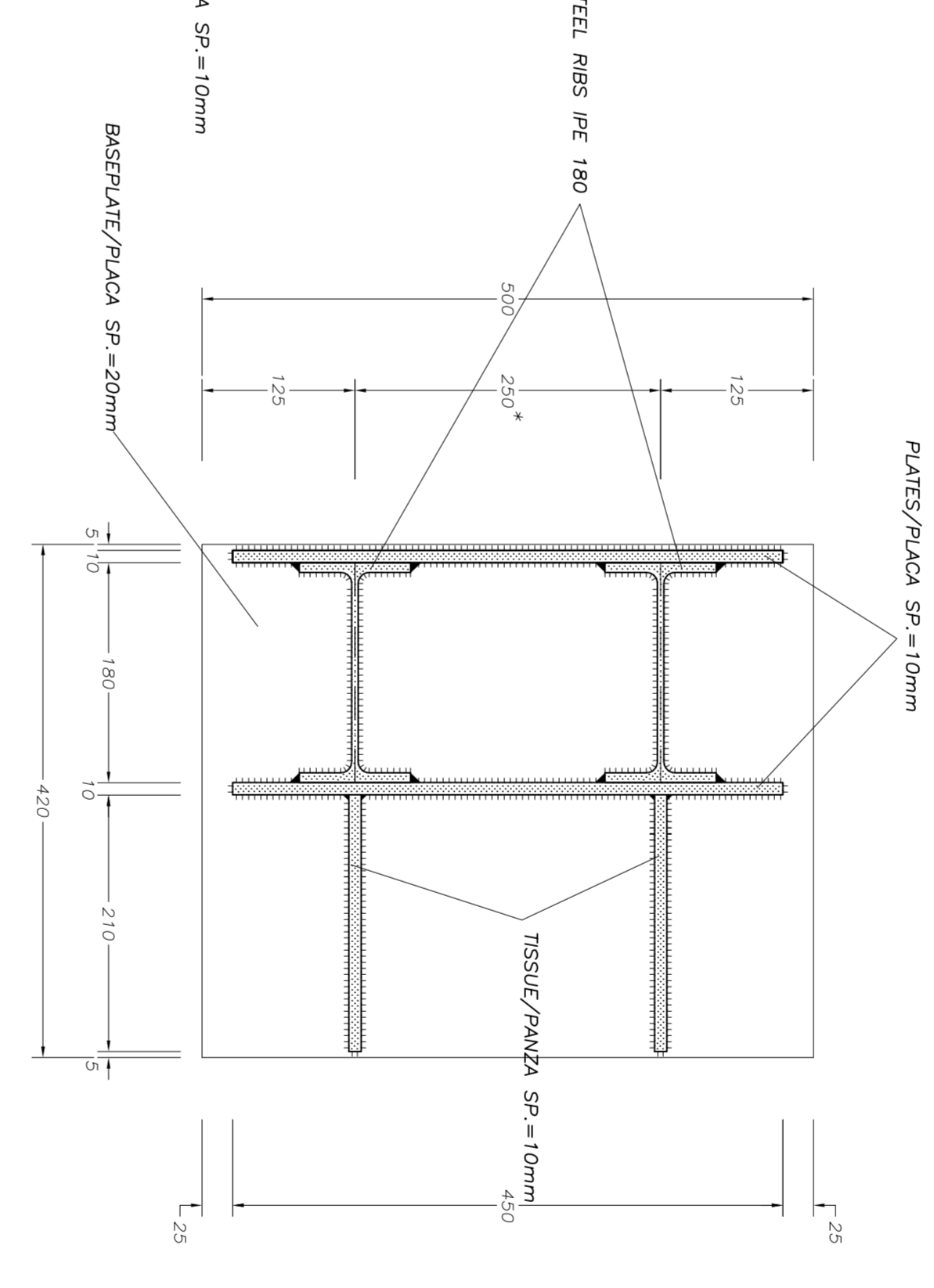

DETAIL "3"
DETAILUL "3"
Scale/Scara 1:5

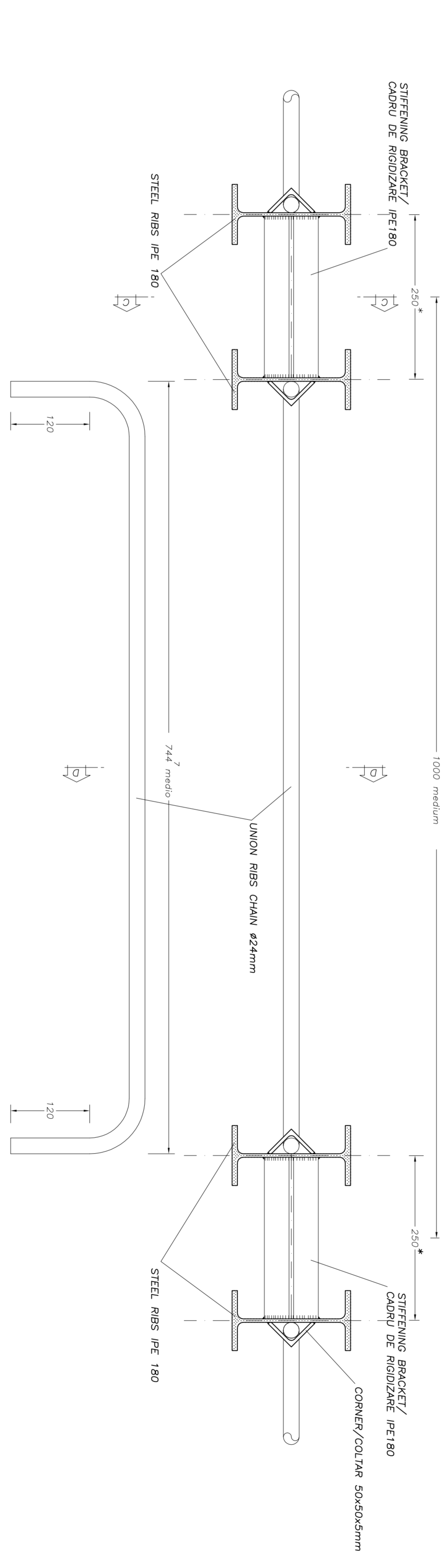

SECTION C-C
SECTIUNI C-C
Scale/Scara 1:5

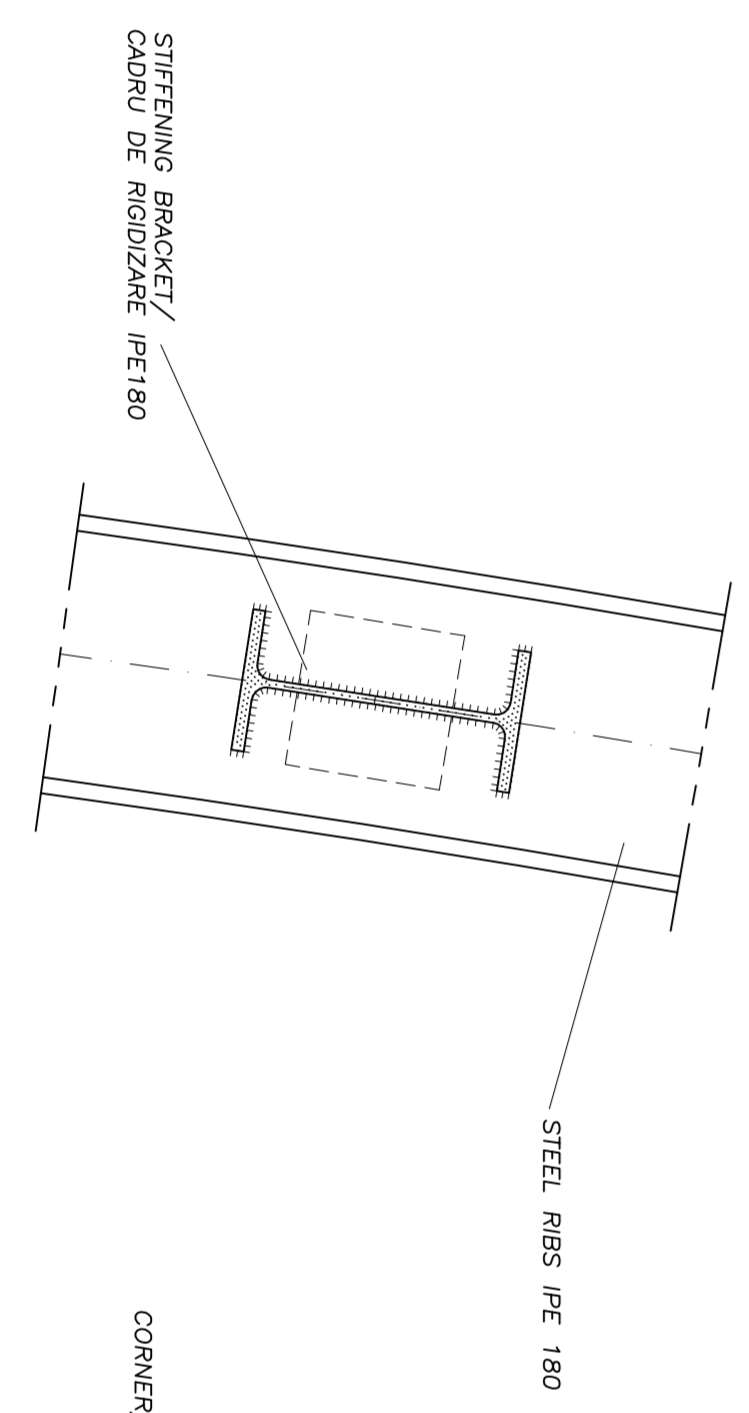

SECTION D-D
SECTIUNI D-D
Scale/Scara 1:5

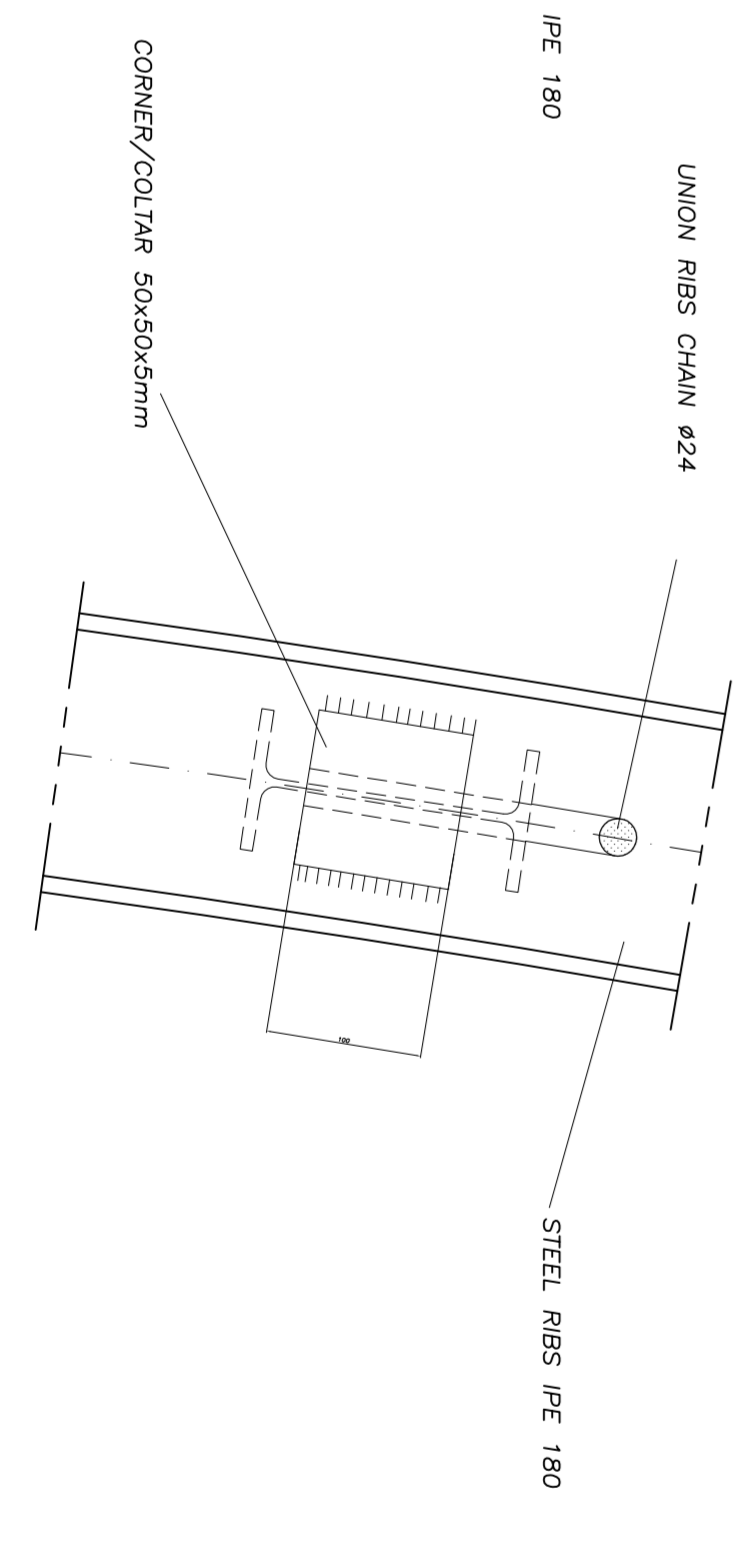

LEGEND
RP = REFERENCE PLANE
EX = EXAMINATIONS PLANE
PC = CEILING PLANE

MATERIAL TABLE
RIBS, PLATE, STEERING, BRACKET, COVER :
- S 275
 $f_{yk} = 430 \text{ MPa}$
 $f_{yk} = 275 \text{ MPa}$
CHAINS :
- B450C controlled by establishment
- Metabolic

MATERIAL TABLE
NERVURI, DE OTEL, SECTIUNI CUPRATI, CAPRUL DE RIBOZARE, UNICAJURI :
- S 275 430 MPa
 $f_{yk} = 275 \text{ MPa}$
LANE :
- B450C controlat de catre unitate
- Metabolic

Index	DATA	Descriere	Proiectant	Amplasat/Consultant	Amplasat/Consultant
A		Modificari			
B					
C					
D					

CLIENT / CLIENT
C.N.C.F. "C.F.R." S.A.

CONSULTANT / CONSULTANT
OBERMEYER TECHNICAL CONSULTING ENGINEERS

SUBCONSULTANT / SUBCONSULTANT
 Approved: [Signature]
 Subcontractor: [Signature]

Project/Proiect
 2024/03/07/2500
 Faza: Proiect
 F.1.11.1.1.0

Denumire desen / Drawing Title :
HOMOROD TUNNEL
 Startul proiectului de studii si detalii
 Inciputul calculului scobit de rezervat din cele 9 detalii

Conditiile / Conditions System	variati / Variations	LOT	Nr. / No
E	A5	1	0
		2	0
		3	0
		4	0
		5	0
		6	0
		7	0
		8	0
		9	0
		10	0