

CURRENT SECTION A-A
 SECȚIUNEA CURENTĂ A-A
 REINFORCEMENTS
 ARMATURĂ
 Scale/Scara 1:50

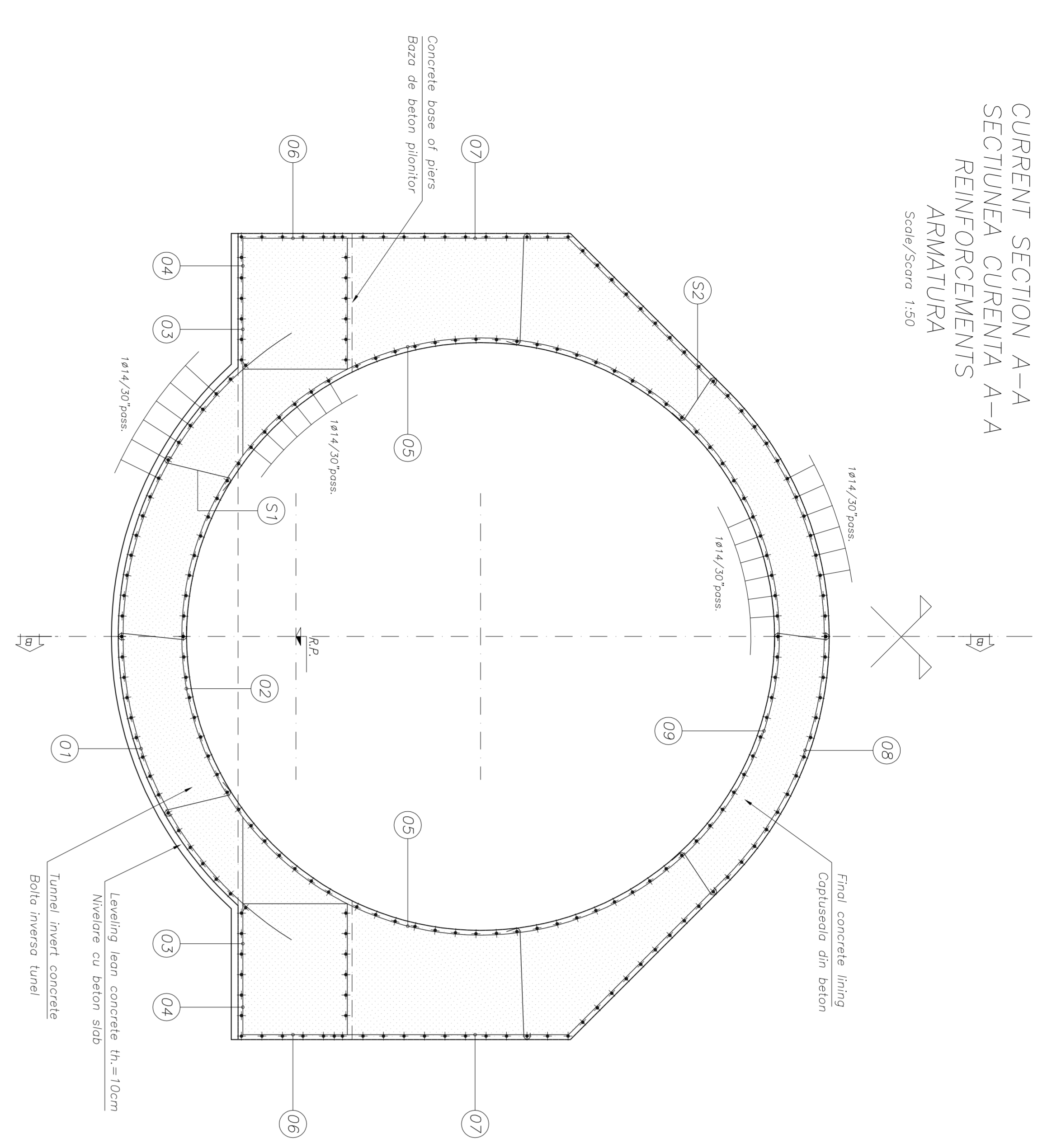

CURRENT SECTION B-B
 SECȚIUNEA CURENTĂ B-B
 Scale/Scara 1:50

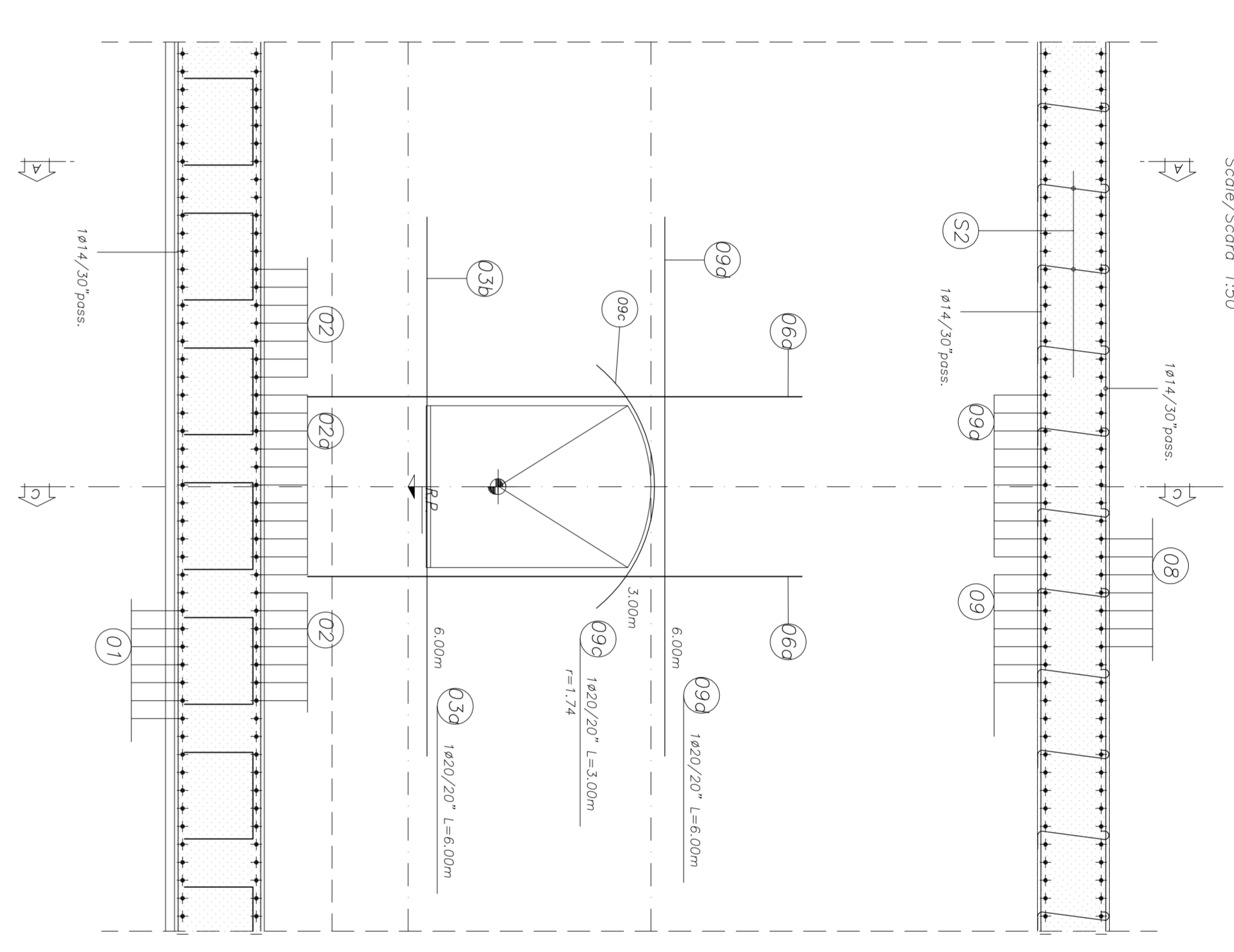

SECTION WITH SHELTER STAFF NICHE C-C
 SECȚIUNEA CU NIȘA PENTRU ADAPOSTUL PERSONALULUI C-C
 Scale/Scara 1:50

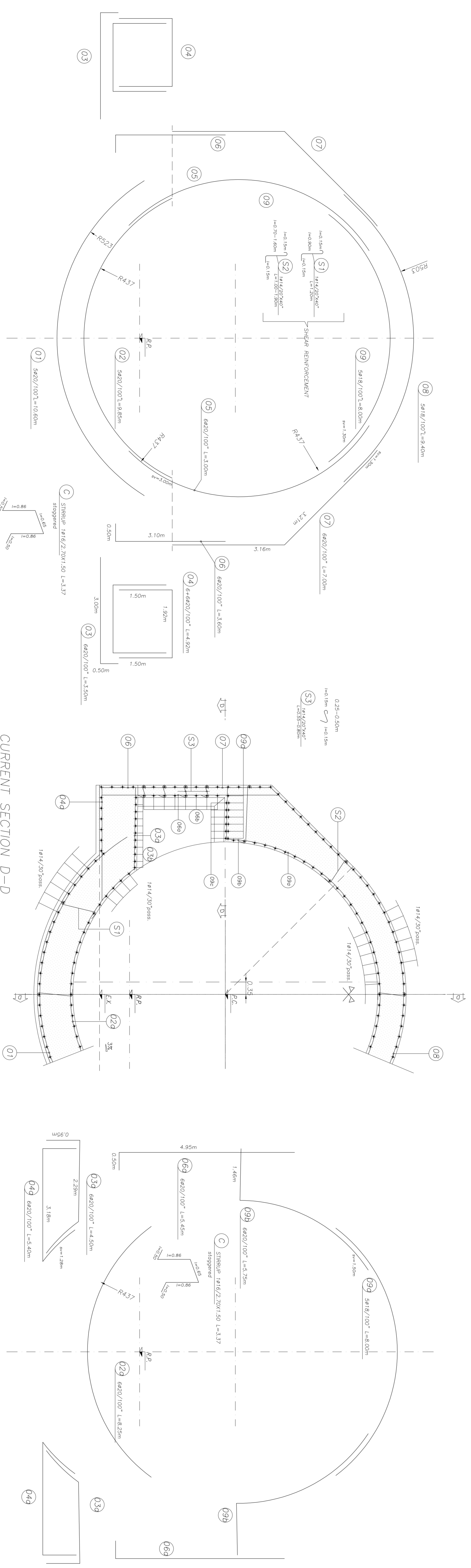

CURRENT SECTION D-D
 SECȚIUNEA CURENTĂ D-D
 Scale/Scara 1:50

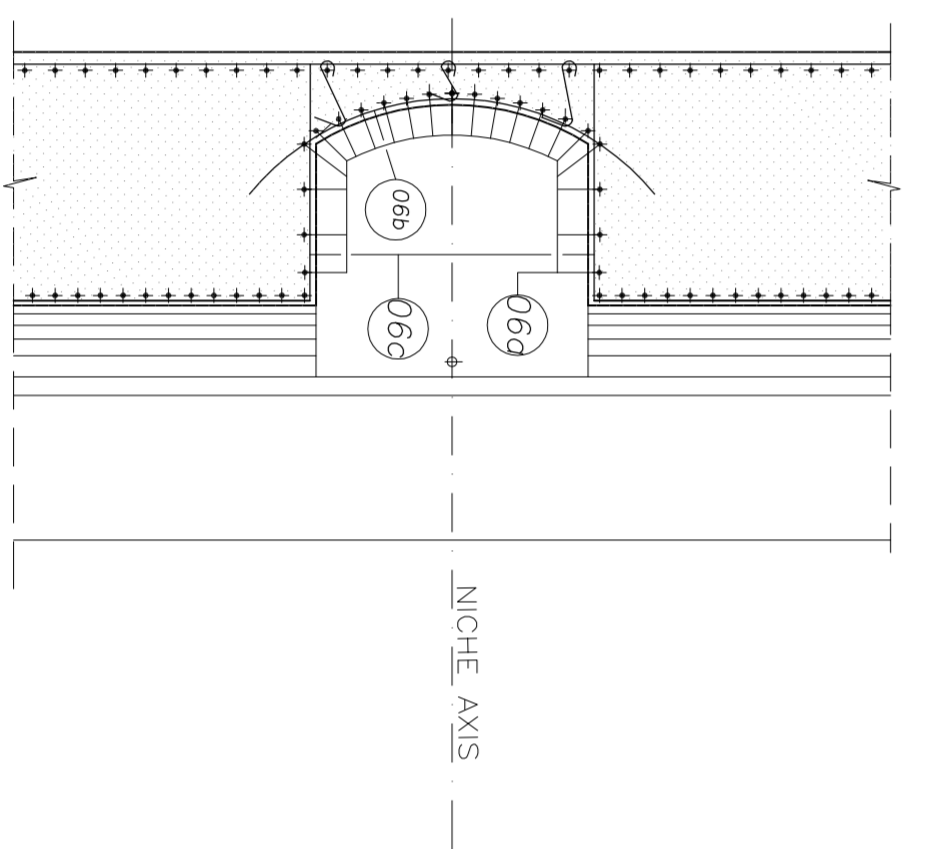

STEELS TABLE

REFERENCE STEEL: B40C (standard)

Legend measures:

Bending diameter R_b : $R_b < 400 \rightarrow R_b = 6a$
 $R_b > 400 \rightarrow R_b = 8a$

Length measures: $R_{st} = d/2$

MATERIAL TABLE

TUNNEL INVERT CONCRETE:

- Type C2
- $f_{ck} = 20$ MPa
- Mineral admixture max. 40 kg/m³
- Mineral admixture max. 10% S1/S4
- Exposure class related to environmental conditions: XE2
- Exposure class related to environmental conditions: XE2
- Class of concrete: C 20
- Class of concrete: C 20
- ρ_{max} aggregate = 20 mm
- ρ_{max} aggregate = 20 mm

REINFORCEMENT STEEL:

- Type C1
- $f_{yk} > 50$ MPa
- Mineral admixture max. 40 kg/m³
- Mineral admixture max. 10% S1/S4
- Exposure class related to environmental conditions: XE2
- Class of concrete: C 20
- Class of concrete: C 20
- ρ_{max} aggregate = 20 mm
- ρ_{max} aggregate = 20 mm

LENN CONCRETE:

- Type C1
- $f_{yk} > 50$ MPa
- Current type: CEM I/V

LEGEND

RP = REFERENCE PLANE
 EX = EXCAVATIONS PLANE
 PC = CENTER PLANE

Index	Date	Modifications	Project Manager	Author/Designer	Approved/Checked
A	2024.01.15	Initial design	R. LUTZA	C. GEMELLI	C. GEMELLI
B	2024.01.20	Revised design	R. LUTZA	C. GEMELLI	C. GEMELLI
C	2024.02.05	Final design	R. LUTZA	C. GEMELLI	C. GEMELLI

CLIENT / CLIENT

CFR
 CN.C.F. "C.F.R." S.A.

CONSULTANT / CONSULTANT

TECNIC
 Consulting Engineers

PROJECT INFORMATION

PROJECT FINANȚATE DE UNIUNEA EUROPEANĂ
 EUROPEAN UNION FINANCED PROJECT

PROJECT/PROIECT

2044/RD/16/974/002
 FAZA: Proiect
 P.N. / P.D.

ORIENTIS TUNNEL

Entrance concrete side
 Tunel artificial, terminal

Scale / Scara

1:50

Code / Cod

101

Revision / Revizuire

01

Date / Data

2024.01.15

Author / Autor

R. LUTZA

Checked / Verificat

C. GEMELLI

Approved / Aprobat

C. GEMELLI