

SECTION A-A scara 1:50

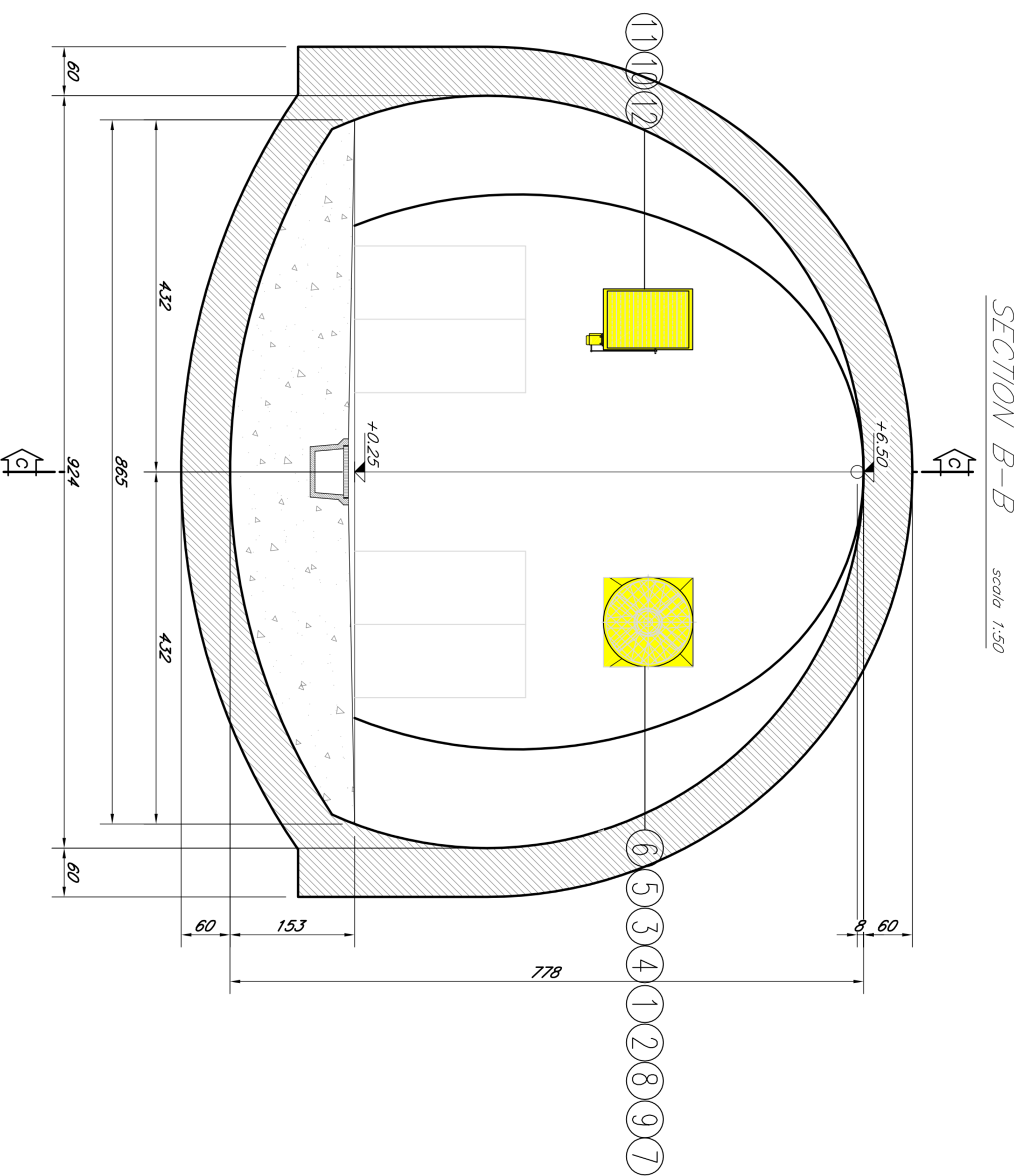

SECTION B-B scara 1:50

- LEGENDA / LEGENDA**
- 1 – JET FAN/VENTILATORIE  $Q=10.6\text{ m}^3/\text{s}$  – P.M.=7.5 kW
  - 2 – PROTECTION NETWORK FAN/VENTILATOR SECURITATE REȚEA
  - 3 – JOINT CIRCULAR-RECTANGULAR IN STEEL PLATE  
MNT CIRCULAR-RECTANGULAR IN PLACA DE OTEL
  - 4 – FLEXIBLE COUPLING FLANGE/FLEXIBILE COUPLARE FLANSĂ
  - 5 – GALVANIZED STEEL FIRE DAMPER Dim.1000x1000mm  
AMORTIZOR FOC IN GALVANIZAT OTEL Dim.1000x1000mm
  - 6 – GRID IN STEEL GALVANIZED Dim.1000x1000mm  
GRID IN OTEL GALVANIZAT Dim.1000x1000mm
  - 7 – GALVANIZED STEEL MUFFLER  
SILENCER IN GALVANIZAT OTEL
  - 8 – SUPPORT ANTIVIBRATION WITH SPRING HELICAL  
SPRINJ SILENT DE PRIMĂNĂRI ELIPEGALE
  - 9 – ANCHORAGE PLATE IN GALVANIZED STEEL Spesi.10mm  
PLACA DE ANCORARE IN OTEL GALVANIZAT Spesi.10mm
  - 10 – FIRE DAMPER IN GALVANIZED STEEL Dim.1000x700mm  
FOC AMORTIZOR IN OTEL GALVANIZAT Dim.1000x700mm
  - 11 – MOTORIZED CONTROL DAMPER IN GALVANIZED STEEL  
AMORTIZOR DE CONTROL MOTORIZAT Dim.1000x100mm
  - 12 – GRID IN STEEL GALVANIZED/GRID IN OTEL GALVANIZAT Dim.1000x700mm
  - 22 – ELECTRIC LOCK/ELECTRIC BLOCARE
  - 23 – DOOR STATUS SENSOR/SENZOR DE STARE USI
  - 24 – AGREEMENT EXIT SIGNS/SEMNIȚA UN ACORD DE IESIRE

**NOTE/NOTE:**  
THE DIMENSIONS ARE EXPRESSED IN CENTIMETERS/DIMENSIUNILE SUNT IN CENTIMETRI

**CLIENT / CLIENT**  
**C.N.C.F. S.A.**

**CONSULTANT / CONSULTANT**  
**S&S+ Wilcoxon**

**PROIECTANȚII DE ÎNDRĂGĂȘIRE**  
 ROMANIA  
**S&S+ Wilcoxon**

**PROIECTANȚII DE ÎNDRĂGĂȘIRE**  
 ROMANIA  
**C.N.C.F. S.A.**

CONSULTANT / CONSULTANT		SUBCONSULTANT / SUBCONSULTANT	
Approved	Project manager	Approved	Project manager
	R. Lutz		C. Ghințibă
Approved	Section 1 Coordinator	Approved	Section 1 Coordinator
	T. Gălbac		P. Anăsoaie
Checked	Technical Engineer	Checked	Technical Engineer
	Brăgăreanu		Brăgăreanu
<b>SUBCONSULTANT / SUBCONSULTANT</b>		<b>SUBCONSULTANT / SUBCONSULTANT</b>	
Approved	Subcontractor responsible	Approved	Subcontractor responsible
	Brăgăreanu		Brăgăreanu

**DATE/DATE:**

Project/Proiect	Drawings/Desene	Date/Date	Scale/Scală
1	1	1	1
2	2	2	2
3	3	3	3
4	4	4	4
5	5	5	5
6	6	6	6
7	7	7	7
8	8	8	8
9	9	9	9
10	10	10	10