

D					
C					
B					
A					
Indice Index	Data Date	Modificare Modification/Revision	Proiectant Designer	Aprobat Consultant Approved Consultant	Aprobat CFR Approved CFR



C.N.C.F. "C.F.R." - S.A.

CLIENT / CLIENT



CONSULTANT / CONSULTANT

		Șef proiect Project manager	R. Liuzza	Data Date	Semnătură Signature
Aprobat Approved					
Aprobat Approved	Coordonator Sectiune 1 Section 1 Coordinator	C. Gambelli			
Verificat Checked	Tunel Expert Tunnel Expert	C. Gambelli			
Intocmit Elaborated	Proiectant Designer	P. Amodio			

SUBCONSULTANT / SUBCONSULTANT

Aprobat Approved	Responsabil Subconsultant Subconsultant Responsible		
Intocmit Elaborated	Proiectant Designer		
Reabilitarea liniei de cale ferata Brașov - Simeria, parte componentă a coridorului IV Pan European, pentru circulația trenurilor cu viteză maximă de 160 km/h. Sectiune 1 Brasov - Sighisoara		Project/Project	2004/RO/16/P/PA/003
Rehabilitation of the railway line Brașov - Simeria, component Part of the IV Pan-European Corridor, for the trains circulation with maximum speed of 160 km/h. Section 1 Brasov - Sighisoara		Faza / Phase: P.Th. / T.D.	

Denumire desen / Drawing Title : **TUNNEL/TUNELUL HOMOROD**

RACOS SIDE/INSPRE RACOS

Emergency and fire protection systems/Sisteme de urgență și de incendiu
Electrical diagram services panel central C1 (Q_SILC1)/Electrice Diagrame cadru servicii centrale C1 (Q_SILC1)

Codificare / Codification System

Scara / Scale	LOT	Nr. / No
-		-

E A 5 1 0 1 C 1 2 L X T S 2 0 7 3 0 0 3 0

1

2

3

4

5

6

7

8

9

CHARACTERISTICS PANEL/CARACTERISTICI CADRU

SYSTEM/SYSTEM

VOLTAGE/TENSIUNE [V] 400 | FREQUENCY/FRECVENTA [Hz] 50
 RETED CURRENT PANEL/CURENT NOMINAL CADRU [A] _____
 SHORT CIRCUIT CURRENT ON PANEL [kA] _____ 16
 DISTRIBUTION SYSTEM/SISTEMUL DE DISTRIBUTIE _____ TNS
 SIZE BARS/DIMENSIUNEA BARS _____
 I_n [A] _____
 S_{cc} [kA] _____
 CARPENTRY/TAMPLARIE _____ METALLIC
 INSULATION CLASS/CLASA DE IZOLARE _____ IP _____

REFERENCE STANDARDS/STANDARDDELE DE REFERINTA











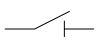
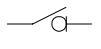













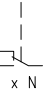





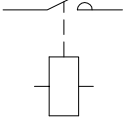
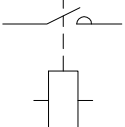
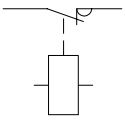
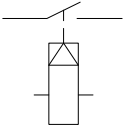

BREAKERS SWITCHES/CIRCUITUL CONCASOARE — EN 60947-2

MODULAR SWITCHES/CIRCUITUL MODULAR — EN 60947-2

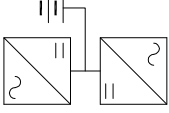
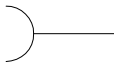
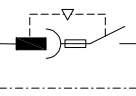
— EN 60898

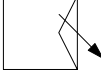
CARPENTRY/TAMPLARIE — EN 60439-1

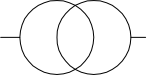
LEGEND SYMBOLS CHEIA SIMBOLURI

	CIRCUIT BREAKER INTERRUPTOR		SWITCH		SWITCH OPERATION SWITCH OPERATIUNEA		THERMAL PROTECTION PROTECTIE TERMICA		MAGNETIC PROTECTION PROTECTIE MAGNETICA		DIFFERENTIAL PROTECTION PROTECTIE DIFERENTIALA		MOTOR MOTOR		FUSE ELEMENT FUZE ELEMENT		TOROID TOROID		MANUAL DRIVE MANUAL
	MOTORIZED CONTROL DE REGLA MOTORIZATE		FREE TRIP CALATORIE GRATUIA		ROTARY HANDLE INTERLOCKING MANER ROTATIV CENTRALIZARE		INTERLOCK INTERBLOCARE		REMOVABLE EQUIPMENT AMOVIBIL ECHIPAMENTE		LOCK KEY (LOCKED WITH APPLIANCE IN PLACE OF REST) LOCK (BLOCAT CU APARATULUI IN POZITIA DE ODHINA)		LOCK KEY (FREE WITH APPLIANCE IN PLACE OF REST) LOCK (GRATUIT CU APARATULUI IN POZITIA DE ODHINA)		AUX CONTACT (N=NUMBER OF INSTALLED CONTACTS,THE HATCH INDICATES WHICH EQUIPMENT PART ACT ON THE CONTACT) DATE DE CONTACT AUX (N=NUMARUL DE DATE INSTALATE. ACT HATCH CU PRIVIRE LA ECHIPAMENTUL INDICA FAPTUL CA DATE)		COIL A MINIMUM VOLTAGE COIL UN VOLTAJ MINIM		COIL A LAUNCH OF CORRENT COIL UN CAUSAREA DE CURENT
	CHANGEOVER SWITCH FOR INSTRUMENT (VOLTMETRIC/AMPERMETRIC) SWITCH PENTRU INSTRUMENT (VOLTMETRIC/AMPERMETRIC)		AMPERMETER AMPERMETRU		VOLTMETER VOLTMETRU		FREQUENCYMETER FRECVENTA		INSTRUMENT INTEGRATOR (CONTACTOR) INSTRUMENT INTEGRATOR (CONTACTOR)		CONTACTOR WITH NO CONTACT CONTACTOR CU DATE DE NO CONTACT		CONTACTOR WITH POSSIBILITY OF MANUAL CONTACT WITH NO CONTACT CONTACTOR CU POSIBILITATEA DE DATE MANUAL CU DE CONTACT NO		CONTACTOR NORMALLY CLOSED CONTACT CONTACTOR CU DATE IN MOD NORMAL INCHIS		CONTACTOR (RELAY 'STEP / STEP') CONTACTOR (RELEU PAS CU PAS)		CLOCK CEASUL
	TWILIGHT CREPUSCULAR		ASTRONOMIC CLOCK CEASUL ASTRONOMIC		UPS UPS		SOCKET (GENERAL SYMBOL) SOCKET (GENERAL SIMBOLURI)		PLUG AND SWITCH FUSE BLOCK SOCKET CU INTERBLOCATA EA SIGURANTI		SOFT STARTER STARTER		INVERTER INVERTOR		STAR STARTER STAR STARTER		TRASFORMER TRASFORMER		SPD VAL

TERMINAL NUMBER/TERMINAL NUMARUL	DISTRIBUTION DISTRIBUTION	ARRIVAL/SOSIRE RSTNPE	2	3	4	5	6	7	8	9
NUMBER OF CIRCUIT NUMARUL DE CIRCUIT										
DESCRIPTION OF THE CIRCUIT DESCRIEREA A CIRCUITULUI										
TYPE APPARATUS/TIP APARATURA										
SWITCH/SWITCH	icu [kA]									
	N. POLI	In [A]	4P	2P	3P	4P	4P			
	CURVE RELEASES/CURBA DE PRESA		C	C	C	C	C			
	I _r [A]	tr [s]	25	10	10	10	10			
	I _{sd} [A]	t _{sd} [s]	250	100	100	100	100			
	i _i [A]									
	I _g [A]	t _g [s]								
DIFFERENTIAL DIFFERENTIAL	TYPE/TIP	CLASS/CLASA								
	I _{dn} [A]	t _{dn} [ms]								
CONTACTOR CONTACTOR	TYPE/TIP	CLASS/CLASA								
	COIL [V]	N. POLE	In [A]							
TERMIC	TYPE/TIP	I _{rth} [A]								
FUSE	N. POLE	In [A]								
OTHER APP. OTHER APP.	TYPE/TIP	MODEL								
PIPELINE/ PIPELINE	TYPE ISOLATION	POSE/INSTALAREA								
	SECTION PHASE-N-PE/PEN [mmq]		EPR	EPR	EPR	EPR	EPR	EPR	EPR	EPR
	I _b [A]	I _z [A]	1x6	1x2,5	1x2,5	1x2,5	1x2,5	1x2,5	1x2,5	1x2,5
	U _n [V]	P _n [kW]	24,1	7,3	3,4	3,4	9,6	2,9	2,9	36
BOTTOM LINE/ FUND LINE	I _{cc} min [kA]	I _{cc} max [kA]	400	230	400	400	400	230	230	36
	LENGTH/LUNGIME[m]	ΔV TOTAL [%]	5	0,6	1,1	1,8	0,6	0,6	0,6	1,6
NOTE			1	0,1	0,9	0,3	0,6	15	15	0,1

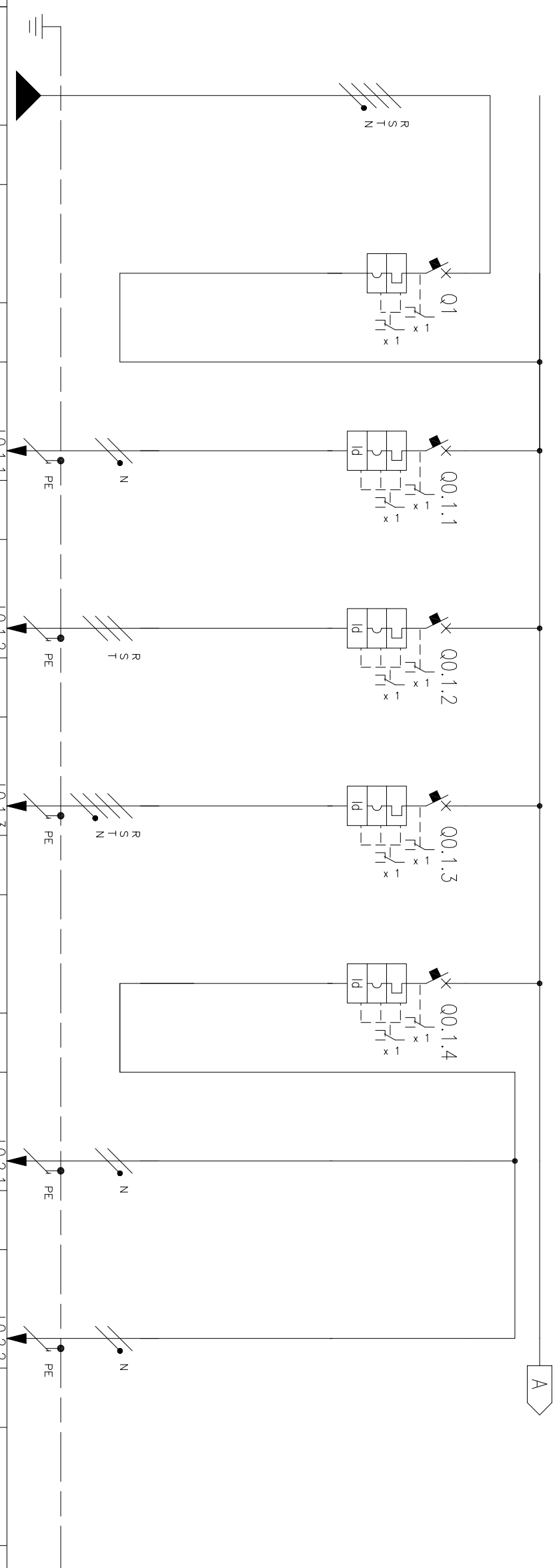

TYPE APPARATUS/TIP APARATURA	NG125 N	C60 H	C60 H	C60 H	C60 H
DESCRIPTION OF THE CIRCUIT	MOTOR PUMP/MOTORUL POMPE	PANEL/CADRU MOTORUL POMPE	POMPA DE DRENAJ POMPEDRENAGE PUMP	HEATER	ELECTRIC VALVE
TYPE/TIP					
CLASS/CLASA					
COIL [V]					
N. POLE					
I _{rth} [A]					
N. POLE					
In [A]					
MODEL					
POSE/INSTALAREA					
SECTION PHASE-N-PE/PEN [mmq]					
I _b [A]					
I _z [A]					
P _n [kW]					
I _{cc} min [kA]					
I _{cc} max [kA]					
LENGTH/LUNGIME[m]					
ΔV TOTAL [%]					

TERMINAL NUMBER/TERMINAL NUMARUL	DISTRIBUTION DISTRIBUTION	8	9	10	11	12	13	14		
NUMBER OF CIRCUIT NUMARUL DE CIRCUIT		ALE7	ALE8	ALE9	ALE10	ALE11	ALE12	ALE13		
DESCRIPTION OF THE CIRCUIT DESCRIEREA A CIRCUITULUI		ELECTRIC VALVE 2	OPEN	CLOSE	ELECTRIC VALVE 3	OPEN	CLOSE	ELECTRIC VALVE MOTOR PUMP		
TYPE APPARATUS/TIP APARATURA		C60 H			C60 H			C60 H		
SWITCH/SWITCH	lcu [kA]	15			15			15		
	N. POLI	4P			4P			4P		
	CURVE RELEASES/CURBA DE PRESA	C			C			C		
	Ir [A]	10			10			10		
	Ird [A]	100			100			100		
	ti [s]									
	tsd [s]									
	ii [A]									
	Ig [A]									
	tg [s]									
DIFFERENTIAL DIFFERENTIAL	TYPE/TIP	CLASS/CLASA								
	I _{dn} [A]	t _{dn} [ms]								
	0,03	Istantaneo						0,03		
CONTACTOR	TYPE/TIP	CLASS/CLASA	LC1D09	AC1	LC1D09	AC1	LC1D09	AC1		
	COIL [V]	N. POLE	230	3 poli	25	230	3 poli	25		
TERMIC	TYPE/TIP	I _{rth} [A]								
FUSE	N. POLE	I _n [A]								
OTHER APP.	TYPE/TIP	MODEL								
PIPELINE/PIPELINE	TYPE ISOLATION	POSE/INSTALAREA								
	SECTION PHASE-N-PE/PEN [mmq]	EPR	1x2,5	1x2,5	1x2,5	1x2,5	1x2,5	1x2,5	1x2,5	1x2,5
	I _b [A]	I _z [A]	2,9	36	0	36	36	1	32	
	U _n [V]	P _n [kW]	230	0,56	230	0,56	230	400	0,56	
BOTTOM LINE/FUND LINE	I _{cc min} [kA]	I _{cc max} [kA]	0,6	1,6	0,6	1,6	0,6	1,8		
	LENGTH/LUNGIME [m]	PEV TOTAL [%]	15	0,4	15	0,1	15	0,1		
NOTE										

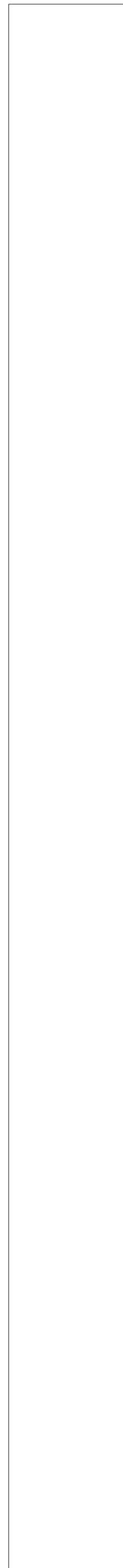

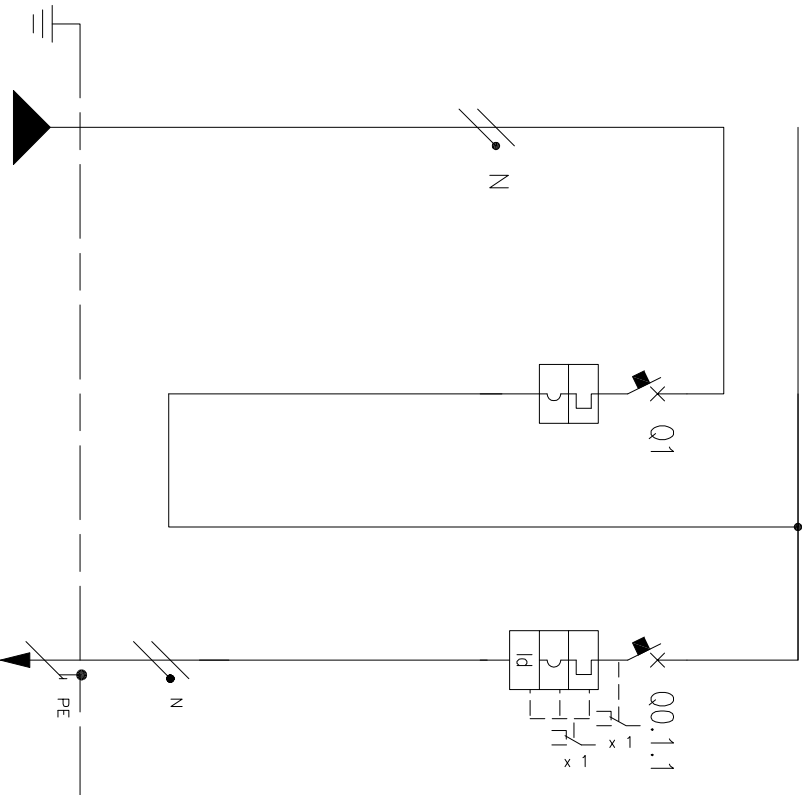

TERMINAL NUMBER/TERMINAL NUMARUL	DISTRIBUTION DISTRIBUTION	ARRIVAL/SOSIRE DA Q_CA	1	2	3	4	5	6	7	8	9
NUMBER OF CIRCUIT NUMARUL DE CIRCUIT			1		L0.1.1						
DESCRIPTION OF THE CIRCUIT DESCRIEREA A CIRCUITULUI					ALC1 AUX. PLC Q_SI LINEA DA Q_CA						
TYPE APPARATUS/TIP APARATURA			C60 L		C60 H						
SWITCH/SWITCH	icu [kA]		15		15						
	N. POLI	In [A]	2P	10	2P	10					
	CURVE RELEASES/CURBA DE PRESA		C		C						
	Ir [A]	tr [s]	10		10						
	I _{sd} [A]	t _{sd} [s]	100		100						
	Ii [A]										
	Ig [A]	tg [s]									
DIFFERENTIAL DIFFERENTIAL	TYPE/TIP	CLASS/CLASA			Vigi	AC					
	I _{dn} [A]	t _{dn} [ms]			0,03	Istantaneo					
CONTACTOR	TYPE/TIP	CLASS/CLASA									
	COIL [V]	N. POLE	In [A]								
TERMIC	TYPE/TIP	I _{rth} [A]									
FUSE	N. POLE	In [A]									
OTHER APP.	TYPE/TIP	MODEL									
PIPELINE/PIPELINE	TYPE ISOLATION	POSE/INSTALAREA			EPR	13					
	SECTION PHASE-N-PE/PEN [mmq]				1x2,5	1x2,5					
	I _b [A]	I _z [A]			0,4	32					
	U _n [V]	P _n [kW]			230	0,3					
BOTTOM LINE/FUND LINE	I _{cc} min [kA]	I _{cc} max [kA]	10		0,6	1,9					
NOTE	LENGHT/LUNGIMEA [m]	ΔV TOTAL [%]			15	0,1					

