

Căderea stației c.f. VANATORI proiectată /
Designed VANATORI station building

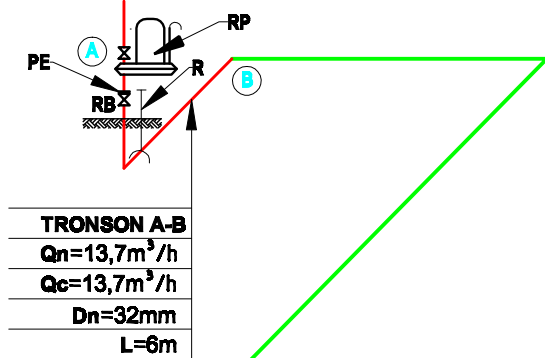

TRONSON A-B
Qn=13,7m ³ /h
Qc=13,7m ³ /h
Dn=32mm
L=6m

TRONSON B-C
Qn=13,7m ³ /h
Qc=13,7m ³ /h
Dn=40mm
L=456m

TRONSON D-
Qn=21,04m ³ /h
Qc=21,04m ³ /h
Dn=40mm
L= -



TRONSON C-D
Qn=7,34m ³ /h
Qc=7,34m ³ /h
Dn=32mm
L=9m

Căderea stației c.f. VANATORI existentă /
VANATORI existing station building

LEGENDA / LEGEND:

- - - - - conducta distribuție gaze naturale, existentă / existing distribution natural gas pipe
- — — — — conducta distribuție gaze naturale, proiectată / designed distribution natural gas pipe
- - - - - bransament gaze naturale, existent / existing natural gas jointing connection
- — — — — bransament gaze naturale, proiectat / designed natural gas jointing connection

- RP - regulator presiune, proiectat / designed pressure controller
- RB - robinet bransament, proiectat / designed connecting valve
- PE - piesa electroizolantă, proiectată / designed electric insulated piece
- R - rasuflătoare, proiectată / designed gas drain
- Qn - debitul nominal / nominal flow
- Qc - debitul de calcul / design flow
- D - diametrul / diameter
- L - lungimea / length
- tronson / section

NOTA / NOTE:

Execuția instalațiilor de alimentare cu gaze naturale se va face numai după obținerea avizelor de la DISTRIGAZ /
The mounting of natural gas installations would be done only after obtaining the agreement from DISTRIGAZ institution.

D					
C					
B					
A					
Indice Index	Data Date	Modificare Modification/Revision	Proiectant Designer	Aprobat Consultant Approved Consultant	Aprobat CFR Approved CFR



GUVERNUL ROMANIEI
ROMANIAN GOVERNMENT

PROIECT FINANȚAT DE UNIUNEA EUROPEANĂ
EUROPEAN UNION FINANCED PROJECT



C.N.C.F. "C.F.R." - S.A.

CLIENT / CLIENT



CONSULTANT / CONSULTANT

			Data Date	Semnătură Signature
Aprobat Approved	Șef proiect Project manager	R. Liuzza	DEC. 2011	
Aprobat Approved	Coordonator Secțiune 1 Section 1 Coordinator	C. Gambelli	DEC. 2011	
Verificat Checked	Expert Verificator Checking Expert	G. Floravanti	DEC. 2011	

SUBCONTRACTANT / SUBCONTRACTOR



Aprobat Approved	Responsabil Subconsultant Subconsultant Responsible	A.Stanclu - Dinulescu	DEC. 2011	
Întocmit Elaborated	Proiectant Designer	Florian Duta	DEC. 2011	

Reabilitarea liniei de cale ferată Brașov - Simeria, parte componentă a coridorului IV Pan European, pentru circulația trenurilor cu viteză maximă de 160 km/h,
Tronsonul : Brașov - Sighișoara
Rehabilitation of the railway line Brașov - Simeria, component Part of the IV Pan-European Corridor, for the trains circulation with maximum speed of 160 km/h,
Section : Brașov - Sighișoara

Proiect/Project
2004/RO/16/P/PA/003

Faza / Phase:
D.E. / .E.D.

Denumire desen / Drawing Title :

**Retele exterioare gaze naturale. Schema izometrica - Stația Vanatori
Vanatori Station - Isometric diagram. Outdoor natural gas network**

Codificare / Codification System

Scara / Scale

LOT / LOT

Nr. / No
01 / 01

E A 5 1 0 1 E 1 7 D X I S 0 0 8 1 0 5 3 1