

LEGENDA
SYMBOLS

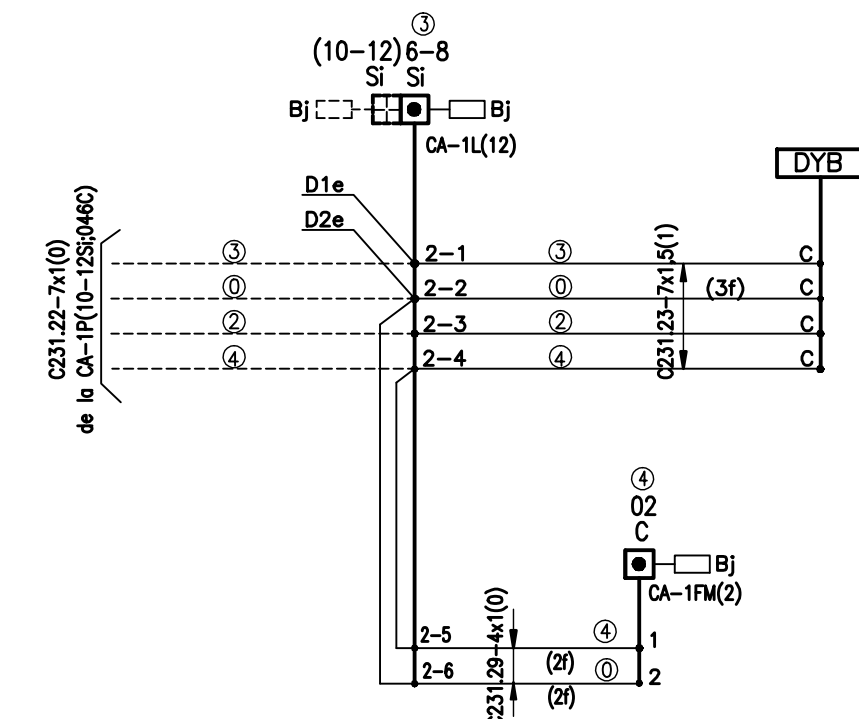
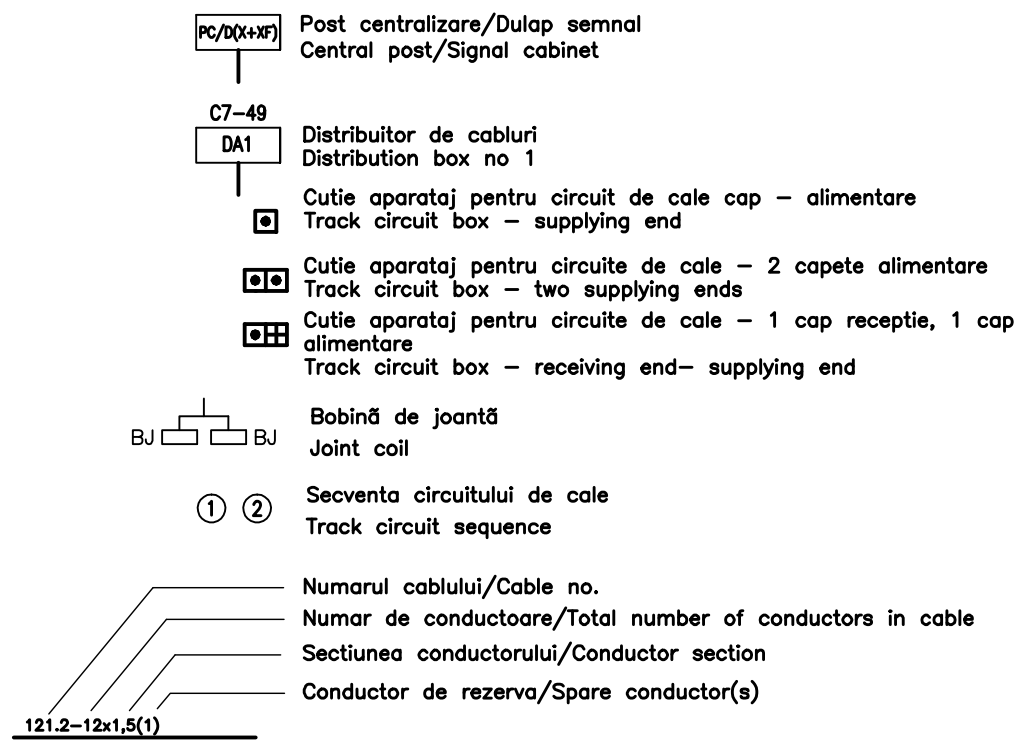

Cablurile 231.23, 231.29

D					
C					
B					
A					
Indice Index	Data Date	Modificari Modification/Revision	Proiectant Designer	Aprobat Consultant Approved Consultant	Aprobat CFR Approved CFR

GUVERNUL ROMANIEI
ROMANIAN GOVERNMENT

PROIECT FINANȚAT DE UNIUNEA EUROPEANĂ
EUROPEAN UNION FINANCED PROJECT

C.N.C.F. "C.F.R." - S.A.
CLIENT / CLIENT

ITAFERR
 GRUPPO FERROVIE DELLO STATO
 Joint Venture leader

Scott Wilson

OBERMEYER
 PLANEN + BERATEN GmbH

TECNIC
 Consulting Engineers

CONSULTANT / CONSULTANT			Data Date	Semnatura Signature
Aprobat Approved	Şef proiect Project manager	R. Ljuzza	12.2011	
Aprobat Approved	Coordonator Sectiune 1 Section 1 Coordinator	C. Gambelli	12.2011	
Verificat Checked	Expert Cheie Key Expert	P. Amodio	12.2011	

SUBCONTRACTANT / SUBCONTRACTOR				
Aprobat Approved	Responsabil Subconsultant Subconsultant Responsible	A. Stanciu - Dinulescu	12.2011	
Intocmit Elaborated	Proiectant Designer	Angelescu Sergiu	12.2011	

Reabilitarea liniei de cale ferata Braşov - Simeria, parte componentă a coridorului IV Pan European, pentru circulația trenurilor cu viteza maximă de 160 km/h,
Tronsonul : Braşov - Sighişoara
Rehabilitation of the railway line Braşov - Simeria, component Part of the IV Pan-European Corridor, for the trains circulation with maximum speed of 160 km/h,
Section : Braşov - Sighişoara

Proiect/Project
2004/RO/16/PPA/003
Faza / Phase:
D.E. / D.D.

Denumire desen / Drawing Title :
Statia / Station BRASOV
Diagrame de cablaj pentru retele de cabluri alimentare
Cable wiring diagrams for supplying boxes

Codificare / Codification System	Scara / Scale Fara / No scale	LOT / LOT	Nr. / No 01 / 01
E A 5 1	0 1	E 0 1	B X S E 0 0 1 2 0 0 5 1