

**LEGENDA
SYMBOLS**

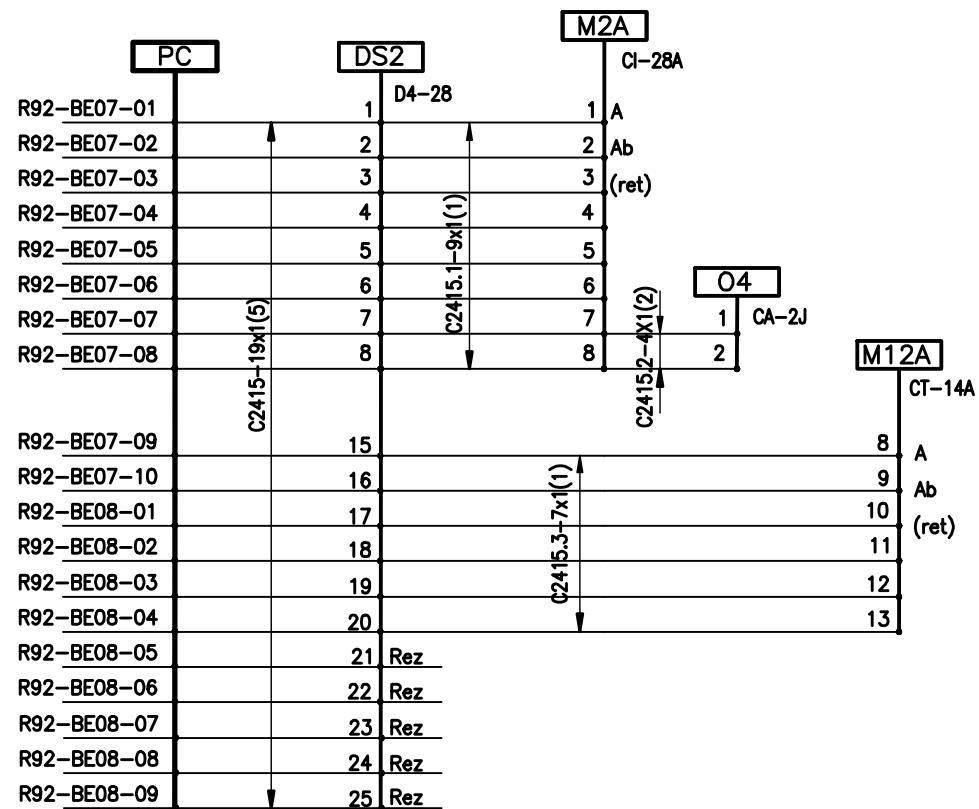

Cablul 2415

D					
C					
B					
A					
Indice Index	Data Date	Modificari Modification/Revision	Proiectant Designer	Aprobat Consultant Approved Consultant	Aprobat CFR Approved CFR

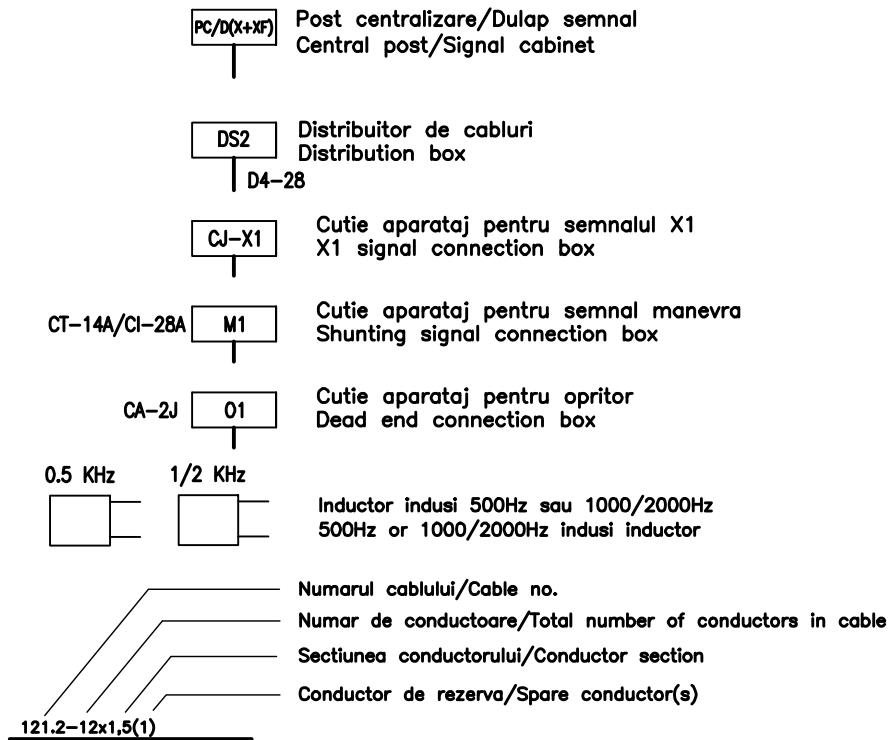

GUVERNUL ROMANIEI
ROMANIAN GOVERNMENT

PROIECT FINANȚAT DE UNIUNEA EUROPEANĂ
EUROPEAN UNION FINANCED PROJECT



C.N.C.F. "C.F.R." - S.A.

CLIENT / CLIENT



CONSULTANT / CONSULTANT

Aprobat Approved	Șef proiect Project manager	R. Ljuzza	Data Date	Semnătură Signature
Aprobat Approved	Coordonator Secțiune 1 Section 1 Coordinator	C. Gambelli	12.2011	<i>[Signature]</i>
Verificat Checked	Expert Cheie Key Expert	P. Amodio	12.2011	<i>[Signature]</i>

SUBCONTRACTANT / SUBCONTRACTOR

Aprobat Approved	Responsabil Subcontractant Subcontractant Responsible	A. Stanciu - Dinulescu	Data Date	Semnătură Signature
Intocmit Elaborated	Proiectant Designer	Angelescu Sergiu	12.2011	<i>[Signature]</i>

Reabilitarea liniei de cale ferată Brașov - Simeria, parte componentă a coridorului IV Pan European, pentru circulația trenurilor cu viteză maximă de 160 km/h,
Tronsonul : Brașov - Sighișoara
Rehabilitation of the railway line Brașov - Simeria, component Part of the IV Pan-European Corridor, for the trains circulation with maximum speed of 160 km/h,
Section : Brașov - Sighișoara

Proiect/Project
2004/RO/16/PPA/003

Faza / Phase:
D.E. / D.D.

Denumire desen / Drawing Title :

Statie / Station BRASOV
Diagrame de cablaj pentru rețele cabluri semnale
Cable wiring diagrams for signals

Codificare / Codification System

Scara / Scale
Fără / No scale

LOT / LOT

Nr. / No
01 / 01

EA51 01 E 01 BX SE 00 1 2 007 1