

LEGENDA
SYMBOLS

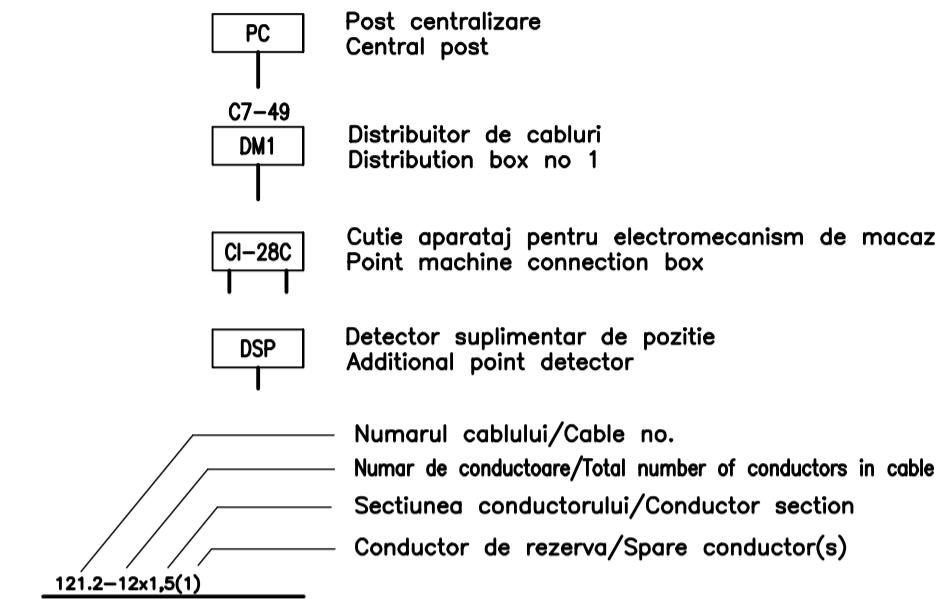

D					
C					
B					
A					
Indice Index	Data Date	Modificari Modifications/Revision	Proiectant Designer	Aprobat Consultant Approved Consultant	Aprobat CFR Approved CFR
		GUVERNUL ROMANIEI ROMANIAN GOVERNMENT		PROIECT FINANȚAT DE UNIUNEA EUROPEANĂ EUROPEAN UNION FINANCED PROJECT	
		C.N.C.F. "C.F.R." - S.A.			
		ITAFERR GRUPPO FERROVIE DELLO STATO Joint Venture leader		Scot Wilson	
		OBERMEYER PLANEN + BERATEIN GmbH		TECNIC Consulting Engineers	
CONSULTANT / CONSULTANT			Data Date	Semnatura Signature	
Aprobat Approved	Suf proiect Project manager	R. Liuzza	12.2011		
Aprobat Approved	Coordonator Sectiune 1 Section 1 Coordinator	C. Gambelli	12.2011		
Verificat Checked	Expert Cheie Key Expert	P. Amodio	12.2011		
SUBCONTRACTANT / SUBCONTRACTOR			Data Date	Semnatura Signature	
Aprobat Approved	Responsabil Subcontractant Subcontractant Responsible	A. Stanciu - Dinulescu	12.2011		
Elaborat Elaborated	Proiectant Designer	Angelescu Sergiu	12.2011		
Reabilitarea liniei de cale ferata Brasov - Simeria, parte componentă a coridorului IV Pan European, pentru circulația trenurilor cu viteză maximă de 160 km/h, Tronsoanel : Brasov - Sighisoara Rehabilitation of the railway line Brasov - Simeria, component Part of the IV Pan-European Corridor, for the trains circulation with maximum speed of 160 km/h, Section : Brasov - Sighisoara			Project/Project 2004/RQ16/PFA/003 Faza / Phase: D.E. / D.D.		
Denumire desen / Drawing Title : Statie / Station FELDIOARA Diagrame de cablaj pentru retele cabluri macazuri Cable wiring diagrams for point machines					
Codificare / Codification System		Scara / Scale Pliat / No scale	LOT / LOT	Nr. / No 01 / 08	
EA51 01 E 07 BX SE 00 7 2 001 1					

