

D					
C					
B					
A					
Indice Index:	Data Date:	Modificari Modification/Revision:	Proiectant Designer:	Aprobat Consultant Approved Consultant:	Aprobat CFR Approved CFR:
GUVERNUL ROMANIEI / ROMANIAN GOVERNMENT		PROIECT FINANȚAT DE UNIUNEA EUROPEANĂ / EUROPEAN UNION FINANCED PROJECT			
		<b>C.N.C.F. "C.F.R." - S.A.</b>			
<b>CLIENT / CLIENT</b>					
<b>CONSULTANT / CONSULTANT</b>		Data Date:		Semnătură Signature:	
Aprobat Approved:	Șef proiect Project manager:	R. Liuzza		12.12.2011	
Aprobat Approved:	Coordonator Secțiune 1 Section 1 Coordinator:	C. Gambelli		12.12.2011	
Verificat Checked:	Expert Cheie Key Expert:	P. Amodio		12.12.2011	
<b>SUBCONTRACTANT / SUBCONTRACTOR</b>		Data Date:		Semnătură Signature:	
Aprobat Approved:	Responsabil Subcontractant Subcontractant Responsible:	A. Stancu - Dinulescu		12.12.2011	
Intocmit Elaborated:	Proiectant Designer:	ing. Juganaru Adriana		12.12.2011	
Reabilitarea liniei de cale ferată Brașov - Simeria, parte componentă a coridorului IV Pan European, pentru circulația trenurilor cu viteză maximă de 160 km/h, Tronsonul : Brașov - Sighișoara / Rehabilitation of the railway line Brașov - Simeria, component Part of the IV Pan-European Corridor, for the trains circulation with maximum speed of 160 km/h, Section : Brașov - Sighișoara		<b>Proiect/Project 2004/RO16/PPA/003</b>		Faza / Phase: D.E. / D.D.	
<b>Denumire desen / Drawing Title :</b>					
<b>Statia / Station APATA</b>					
Diagrame de cablaj pentru rețele de cabluri alimentare / Cable wiring diagrams for supplying boxes					
Codificare / Codification System:		Scara / Scale / Fișă / No scale:		LOT / LOT:	
EA51 01 E 09 BX SE 00 9 2 005 1					

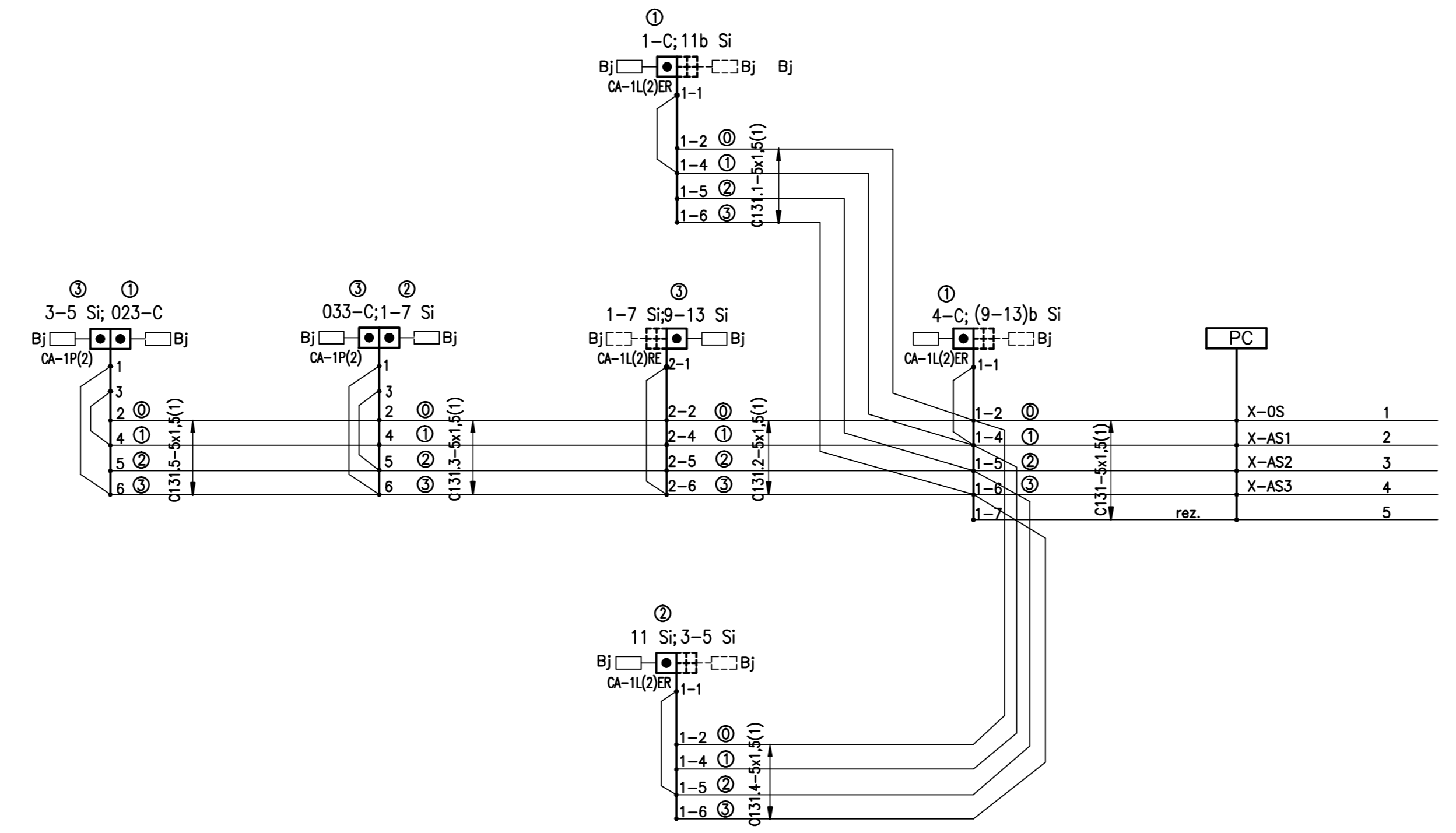

Cablul : 131

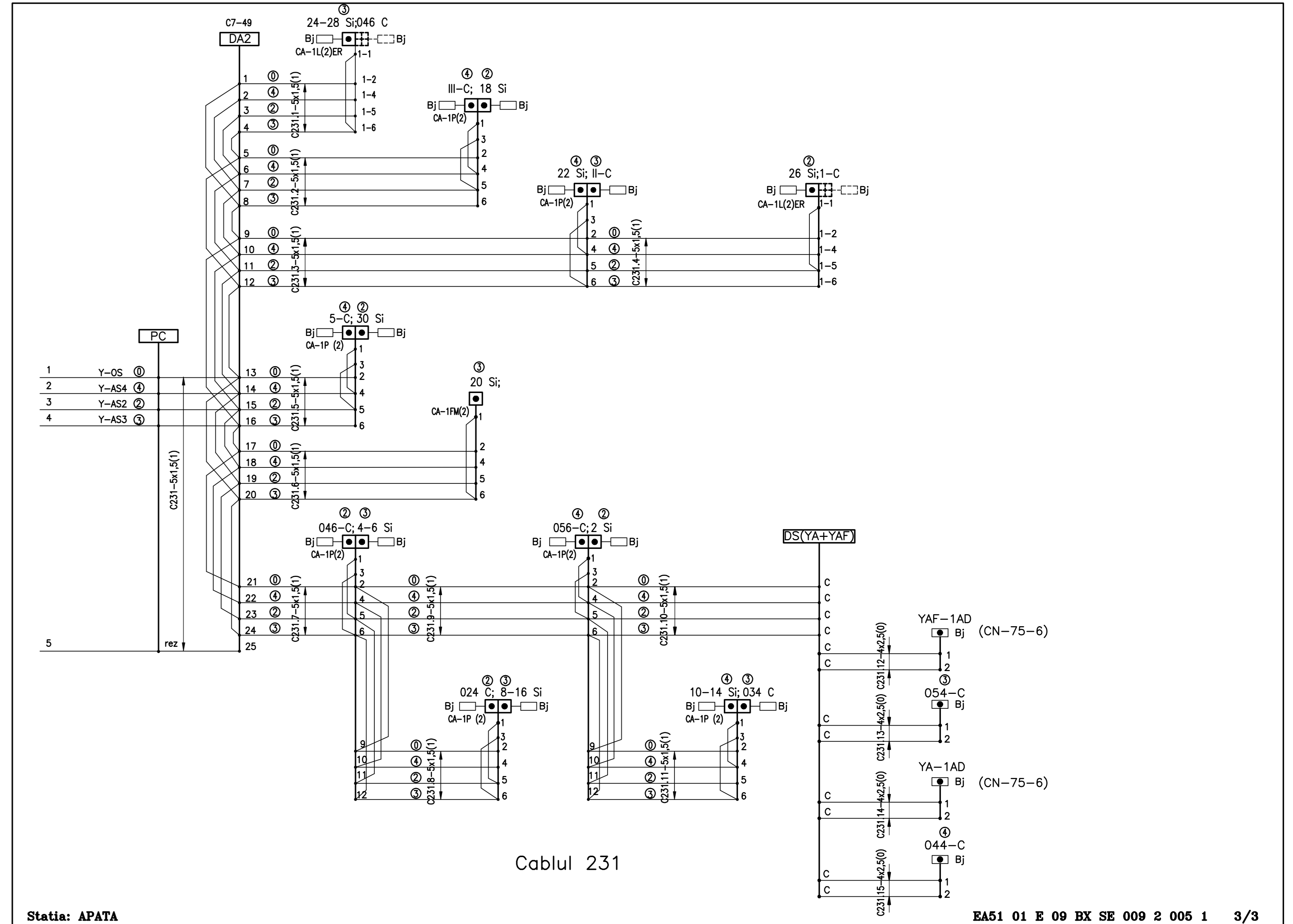

Cablul 231