

LEGENDA  
SYMBOLS

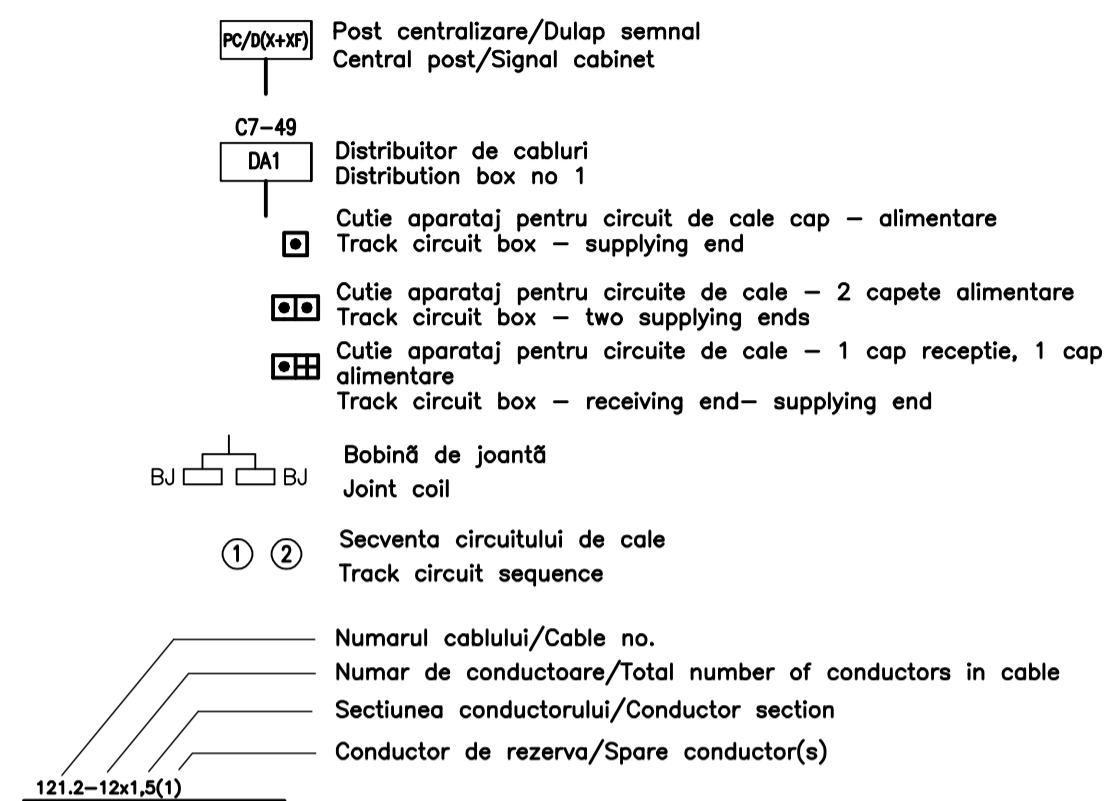

D					
C					
B					
A					
Indice	Data	Modificari	Proiectant	Aprobat Consultant	Aprobat CFR
Index	Date	Modifications/Revision	Designer	Approved Consultant	Approved CFR

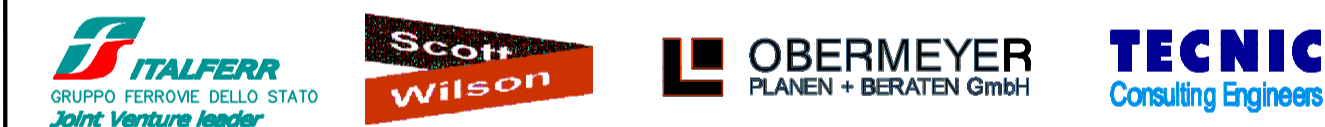

CONSULTANT / CONSULTANT		Data	Semnătură
Aprobat	Suf. proiect		
Approved	Project manager	R. Liuzza	12.2011
Aprobat	Coordonator Secțiune 1		
Approved	Section 1 Coordinator	C. Gambelli	12.2011
Verificat	Expert Cheie		
Checked	Key Expert	P. Amodio	12.2011

SUBCONTRACTANT / SUBCONTRACTOR		Data	Semnătură
Aprobat	Responsabil Subcontractant		
Approved	Subcontractant Responsible	A. Stancu - Dinulescu	12.2011
Elaborat	Proiectant		
Elaborated	Designer	Angelescu Sergiu	12.2011

Reabilitarea liniei de cale ferată Braşov - Simeria, parte componentă a coridorului IV Pan European, pentru circulația trenurilor cu viteză maximă de 160 km/h,  
 Tronçonul : Braşov - Sighişoara  
 Rehabilitation of the railway line Braşov - Simeria, component Part of the IV Pan-European Corridor, for the train circulation with maximum speed of 160 km/h,  
 Section : Braşov - Sighişoara

Project/Project  
 2004/R016/PFA/003  
 Faşa / Phase:  
 D.E. / D.D.

Denumire desen / Drawing Title :

Stația / Station CATA  
 Diagrame de cablaj pentru rețele de cabluri alimentare  
 Cable wiring diagrams for supplying boxes

Codificare / Codification System	Scara / Scale	LOT / LOT	Nr. / No
	Fișă / No scale		01 / 08

EA51 01 E 13 BX SE 01 3 2 005 1

