

PLATES DETAIL/PLACI DETALIU

Scale/Scara 1:10

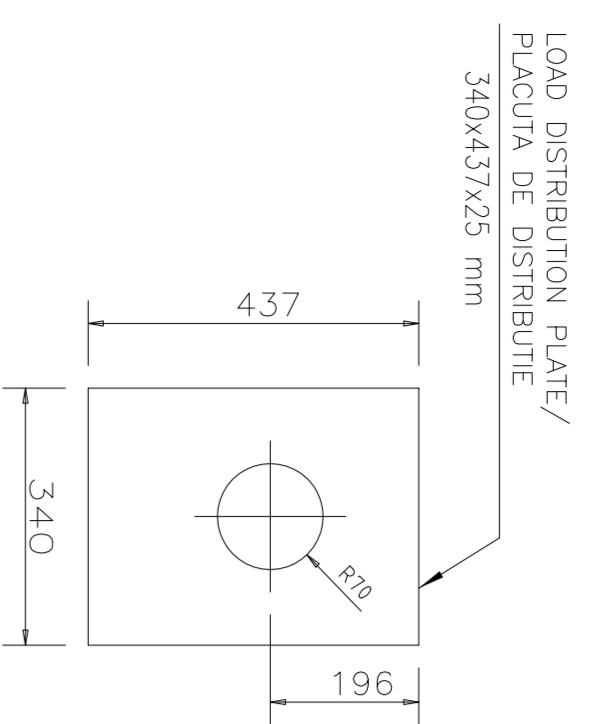

ANCHORS DETAIL/ANCORE DETALIU

Scale/Scara 1:5

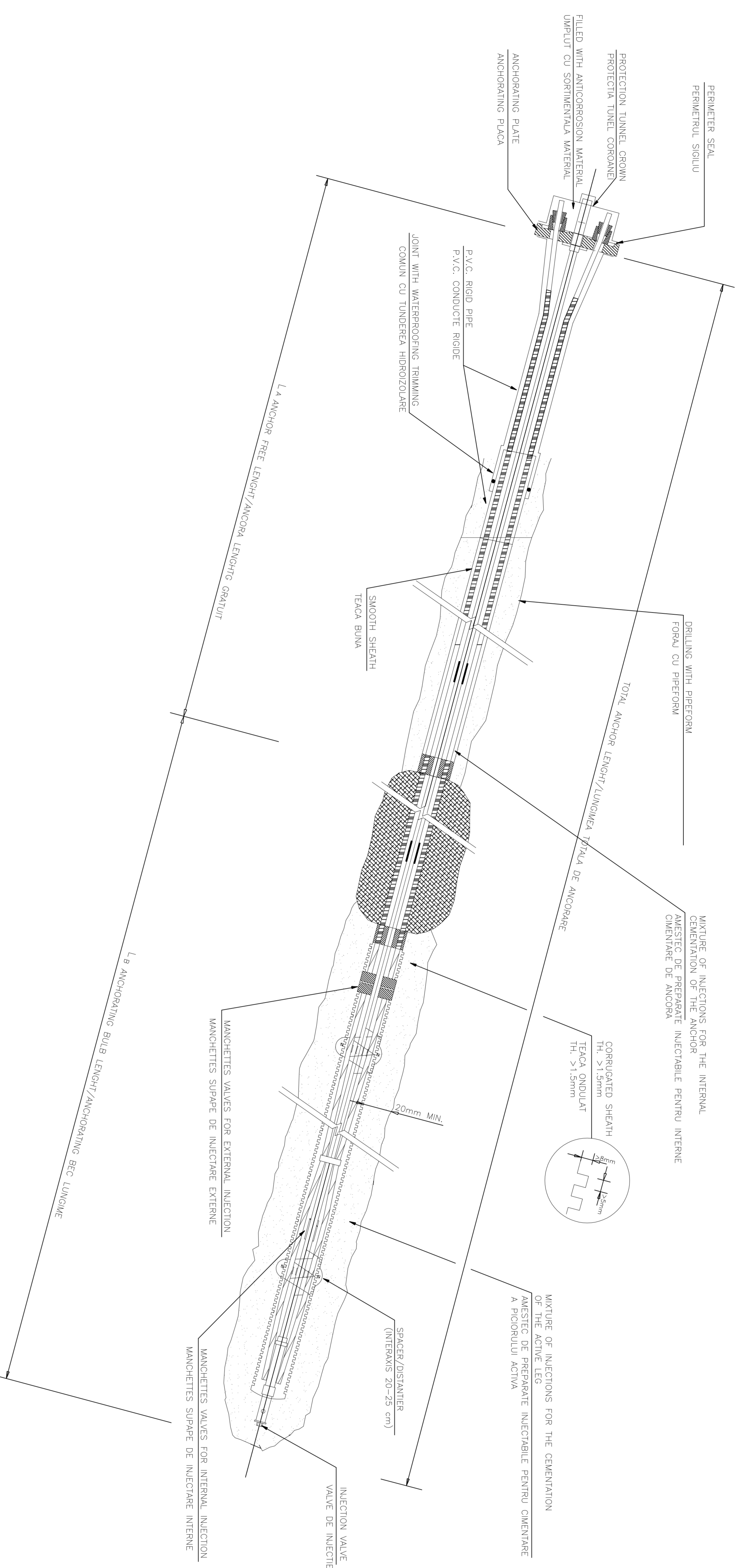

ANCHOR PILES CURB REINFORCED DETAIL

Scale/Scara 1:10

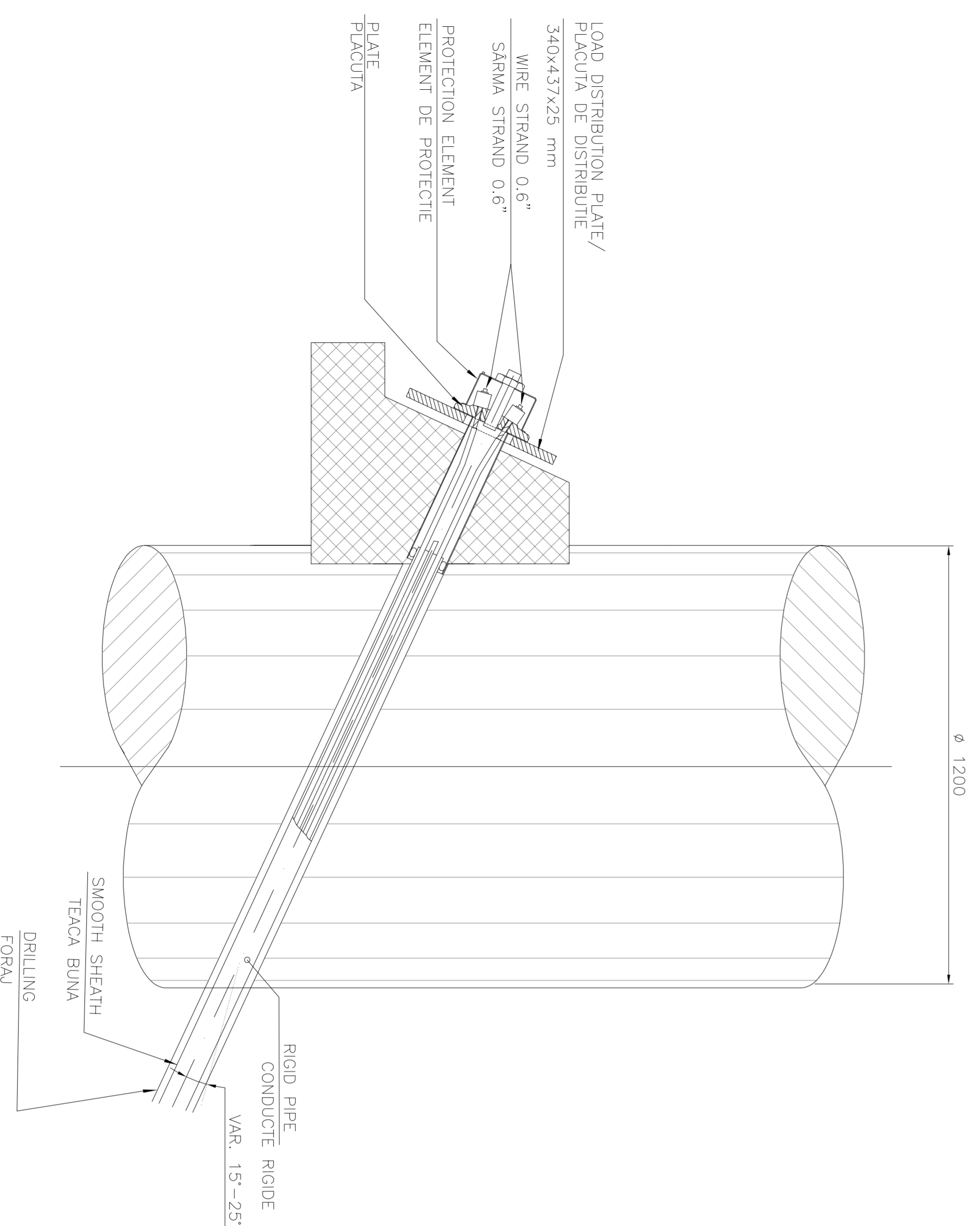

PILES PLAN/PILOTI PLAN

Scale/Scara 1:10

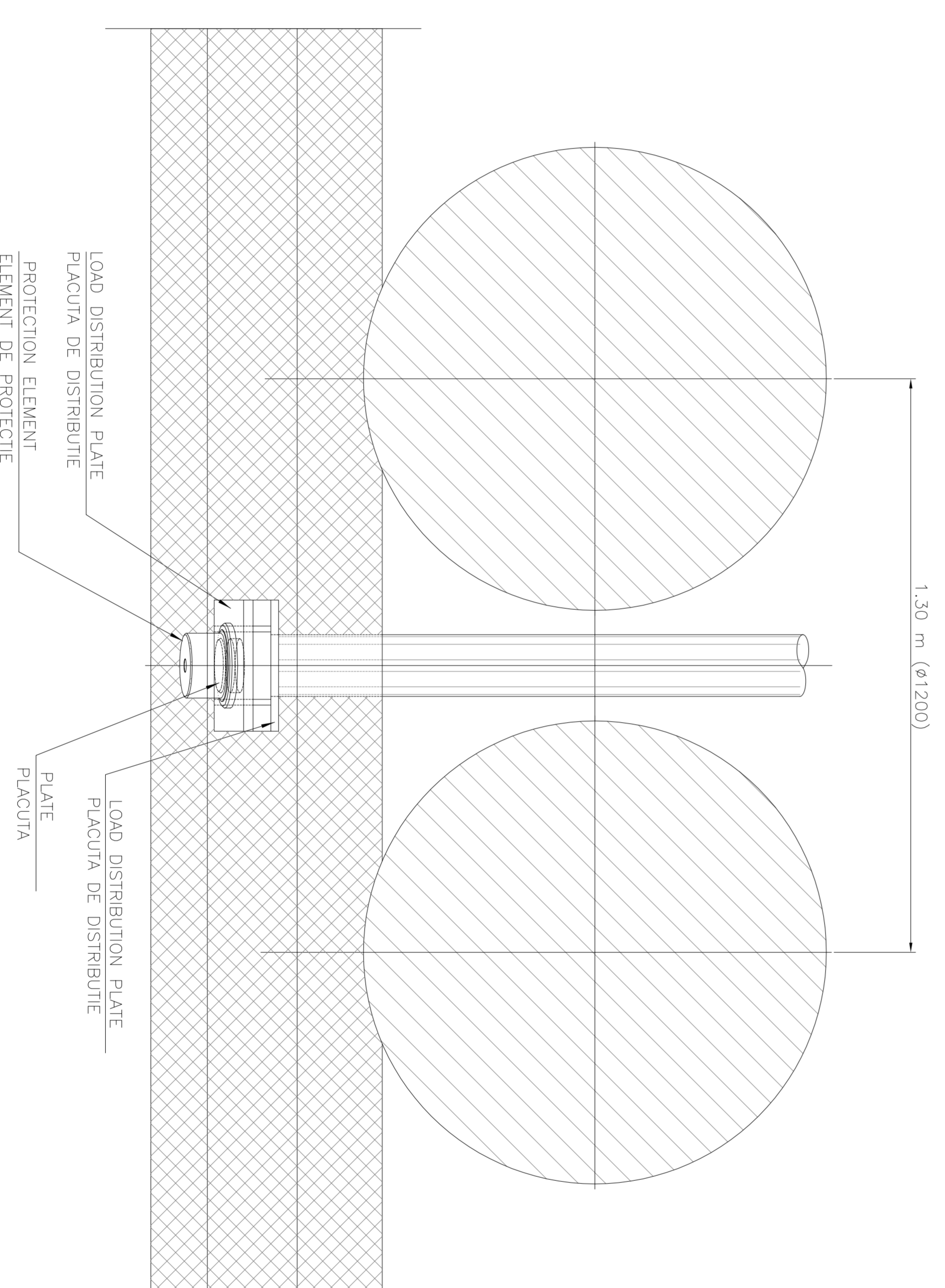

MATERIAL/MATERIALE

- STEEL/OTEL:
 - Fe S10
 - Øs = 133 mm , s = 12.5 mm
- REINFORCED CONCRETE PILE/BETON ARMAT PILE:
 - concrete/Beton >= 30 MPa
 - type/tip S4
 - concrete cover = 5 cm
 - reinforcing steel: B 450 C
- ANCHOR:
 - wire strand specifications: diameter mm 15.50 (6/10)
 - section mmq 139
 - steel for prestressed concrete: f_{yk} >= 1850 N/mm²
 - f_p k >= 1670 N/mm²
 - injection pipe: minimum diameter = 18 mm
 - for low pressure injection: >10 MPa
 - for high pressure injection: mixed concrete for injection
 - total chlorine content of less than 0.05% of the weight of concrete and the content of total sulphur in the lower weight of 0.15% of cement to avoid danger stress corrosion.
 - smooth end corrugated sheath polyethylene or polypropylene

0									
1									
2									
3									
4									
5									
6									
7									
8									
9									
10									

CLIENT / CLIENT 		CLIENT / CLIENT 	
CONSULTANT / CONSULTANT 		CONSULTANT / CONSULTANT 	
Approved: R. LUTZA Author: C. GEMELLI Verified: C. GEMELLI Issued: C. GEMELLI	Date: _____ Date: _____ Date: _____ Date: _____	Approved: _____ Author: _____ Verified: _____ Issued: _____	Date: _____ Date: _____ Date: _____ Date: _____
SUBCONSULTANT / SUBCONSULTANT Approved: _____ Author: _____ Verified: _____ Issued: _____		Approved: _____ Author: _____ Verified: _____ Issued: _____	

Reproduction of the railway line bridge - Simona, parts component a zosterului TV Pan European, pentru dealul Simona cu viteza maxima de 160 km/h. Particular section: Section 1 Brailov - Sibitova Section 1 Brailov - Sibitova	Proiect/Project Z044/R02/16/29/2002 Faza /Phase: P.I.N. / I.D.
--	---

Confiderea / Confidentiality: S, N, P E A S I 0 1 C 1 4 B Z G A 0 7 0 0 0 0 4 0	Status / Statut: _____ Variant / Varianta: _____ LOT: _____ Nr. / No: _____
--	--