

PILES WALL/PILA  
Ø1200/1.30m  
H=15.00m  
Scale/Scale 1:50

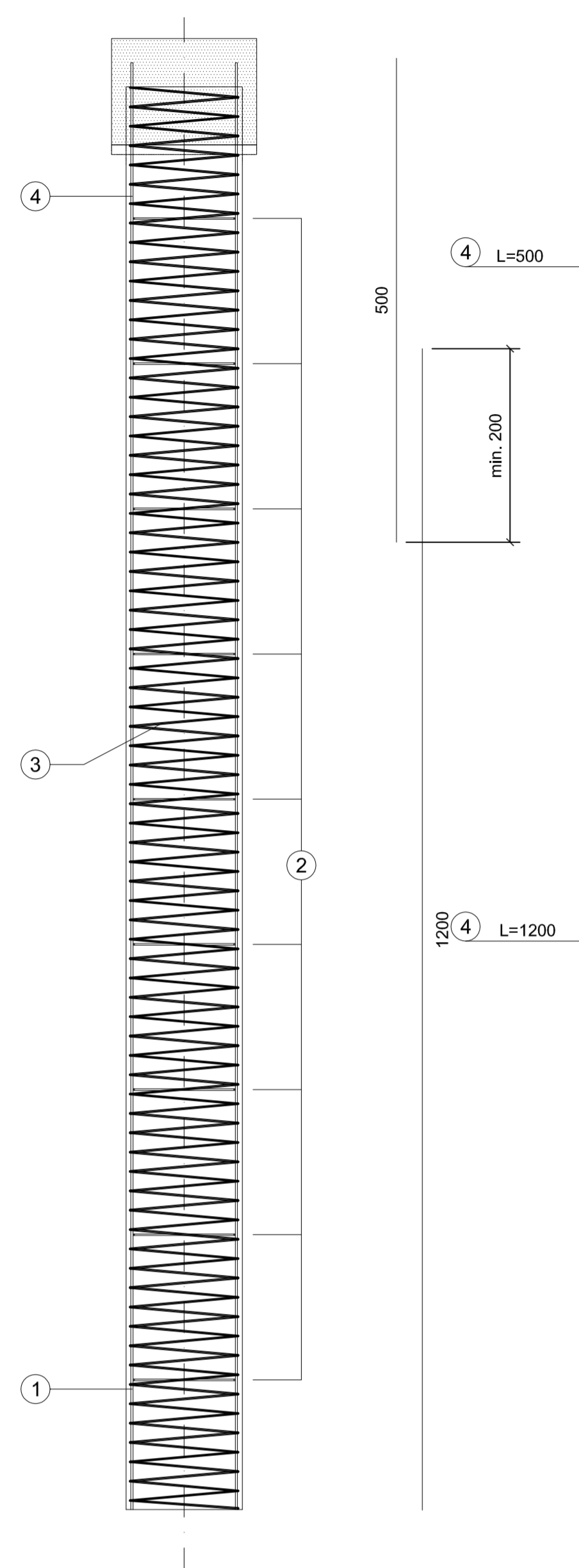

PILES WALL/PILA  
Ø1200/1.30m  
H=17.00m  
Scale/Scale 1:50

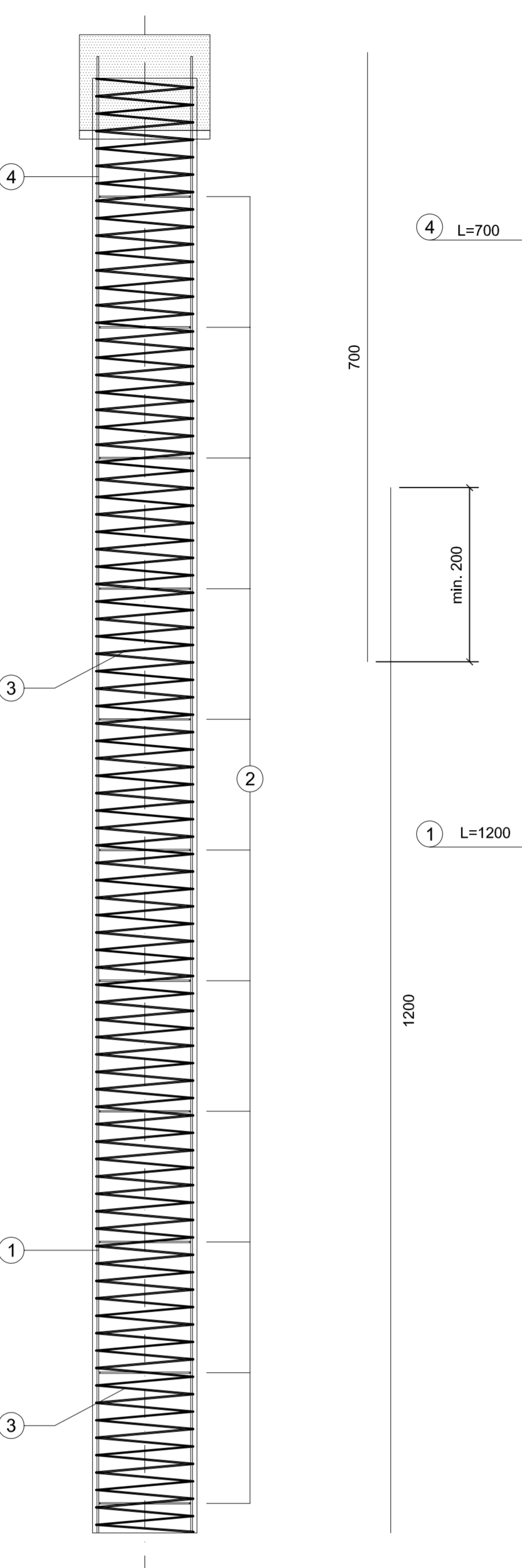

PILES WALL/PILA  
Ø1200/1.30m  
H=22.00m  
Scale/Scale 1:50

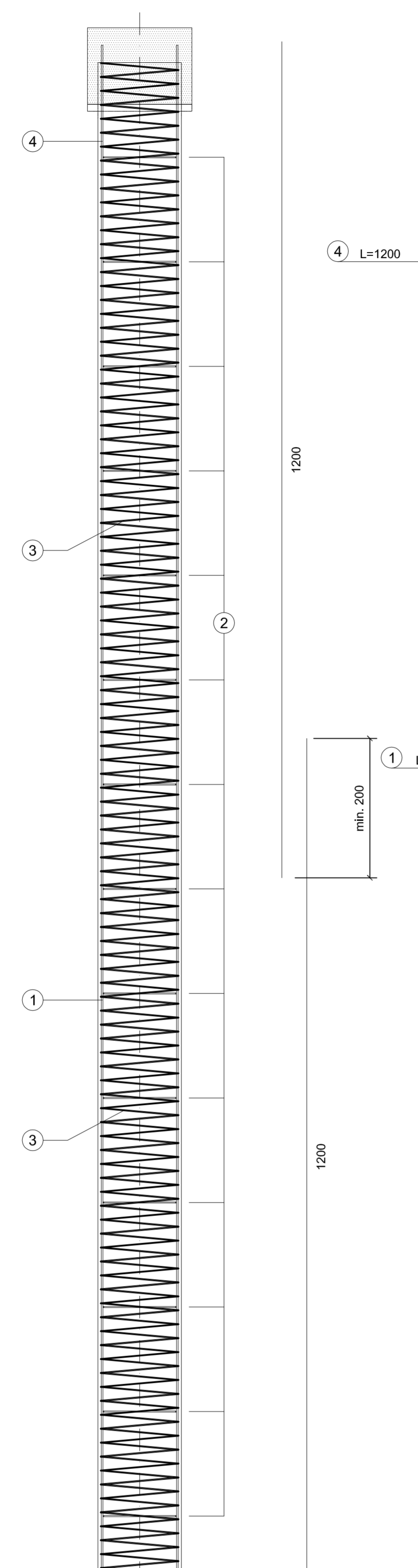

PILES WALL/PILA  
Ø1200/1.30m  
H=25.00m  
Scale/Scale 1:50

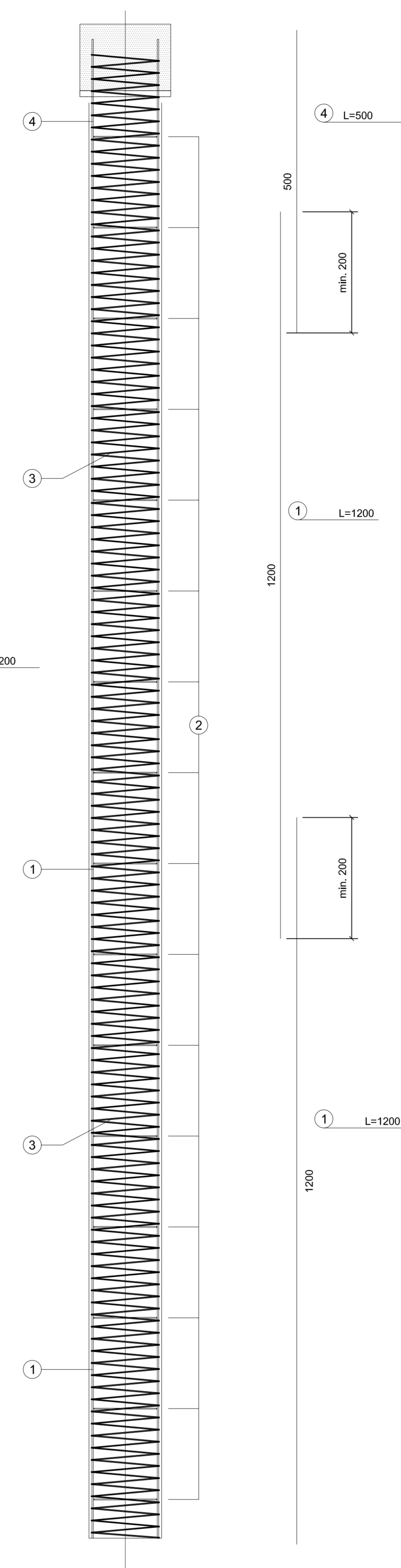

PILES WALL/PILA  
Ø1200/1.30m  
H=28.00m  
Scale/Scale 1:50

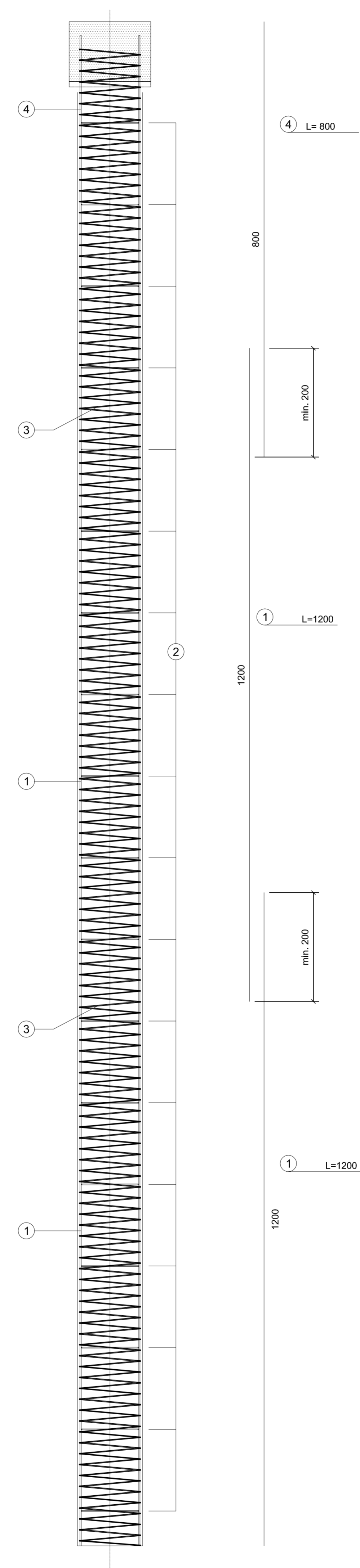

PILES WALL/PILA Ø1200/1.30m  
H=15.00m TIPE/TIP 1

POS.	Ø [mm]	FORM	LENGHT [cm]
1	14	1200	1200 20
2	20 / 1500	345	345 9
3	12 / 200	348	348 75
4	20	500 (200)	500 26

PILES WALL/PILA Ø1200/1.30m  
H=17.00m TIPE/TIP 2

POS.	Ø [mm]	FORM	LENGHT [cm]
1	16	1200	1200 20
2	20 / 1500	345	345 11
3	12 / 200	348	348 83
4	20	700 (200)	700 26

PILES WALL/PILA Ø1200/1.30m  
H=22.00m TIPE/TIP 3

POS.	Ø [mm]	FORM	LENGHT [cm]
1	20	1200	1200 26
2	20 / 1500	345	345 14
3	12 / 200	348	348 109
4	16	1200 (200)	1200 20

PILES WALL/PILA Ø1200/1.30m  
H=25.00m TIPE/TIP 4

POS.	Ø [mm]	FORM	LENGHT [cm]
1	26	1200	1200 30
2	20 / 1500	345	345 16
3	12 / 200	348	348 122
4	26	510 (200)	510 35

PILES WALL/PILA Ø1200/1.30m  
H=28.00m TIPE/TIP 5

POS.	Ø [mm]	FORM	LENGHT [cm]
1	26	1200	1200 35
2	20 / 1500	345	345 18
3	14 / 200	348	348 137
4	26	800 (200)	800 35

PILES WALL/PILA Ø1200/1.30m  
H=15.00m

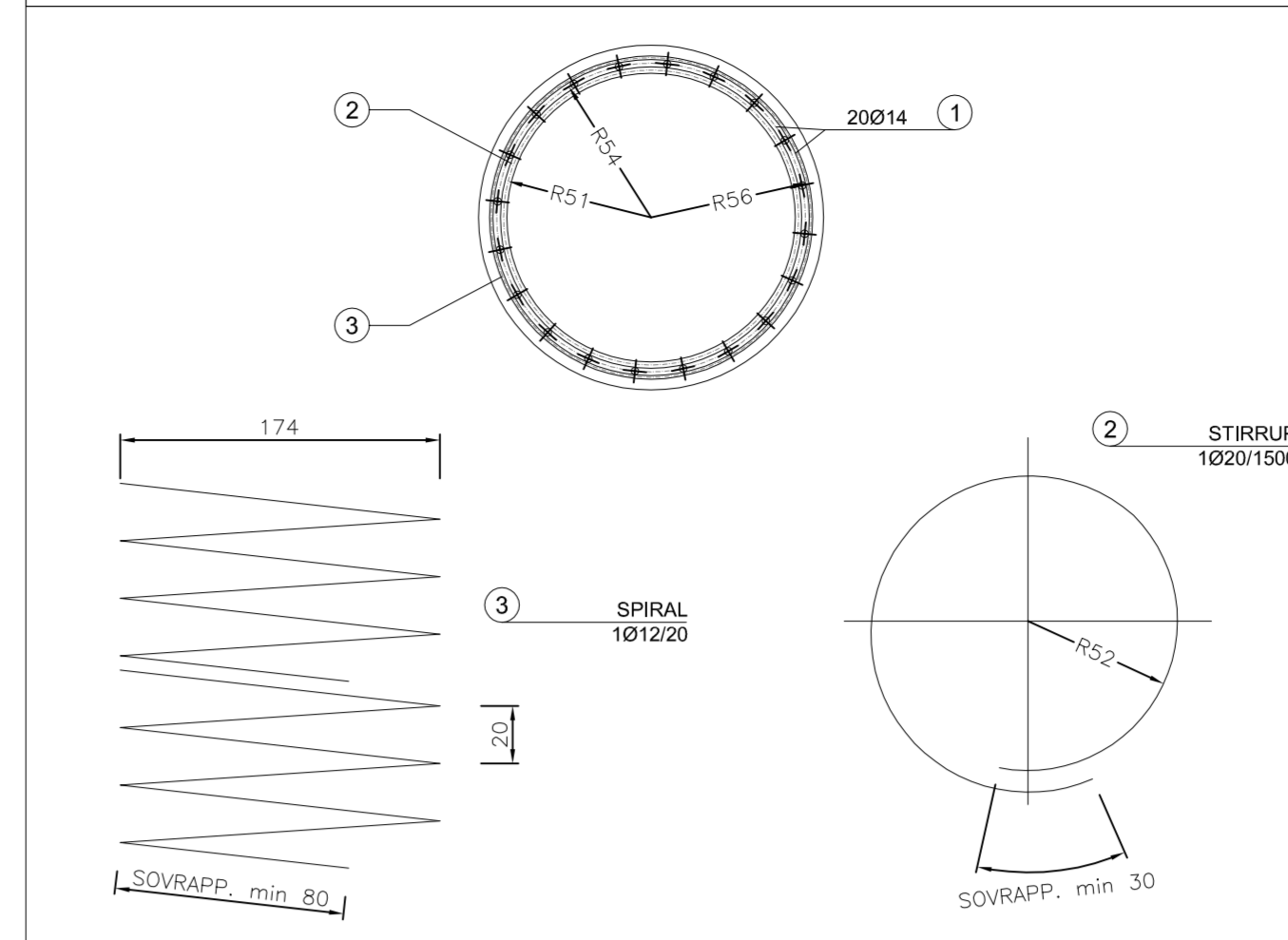

PILES WALL/PILA Ø1200/1.30m  
H=17.00m

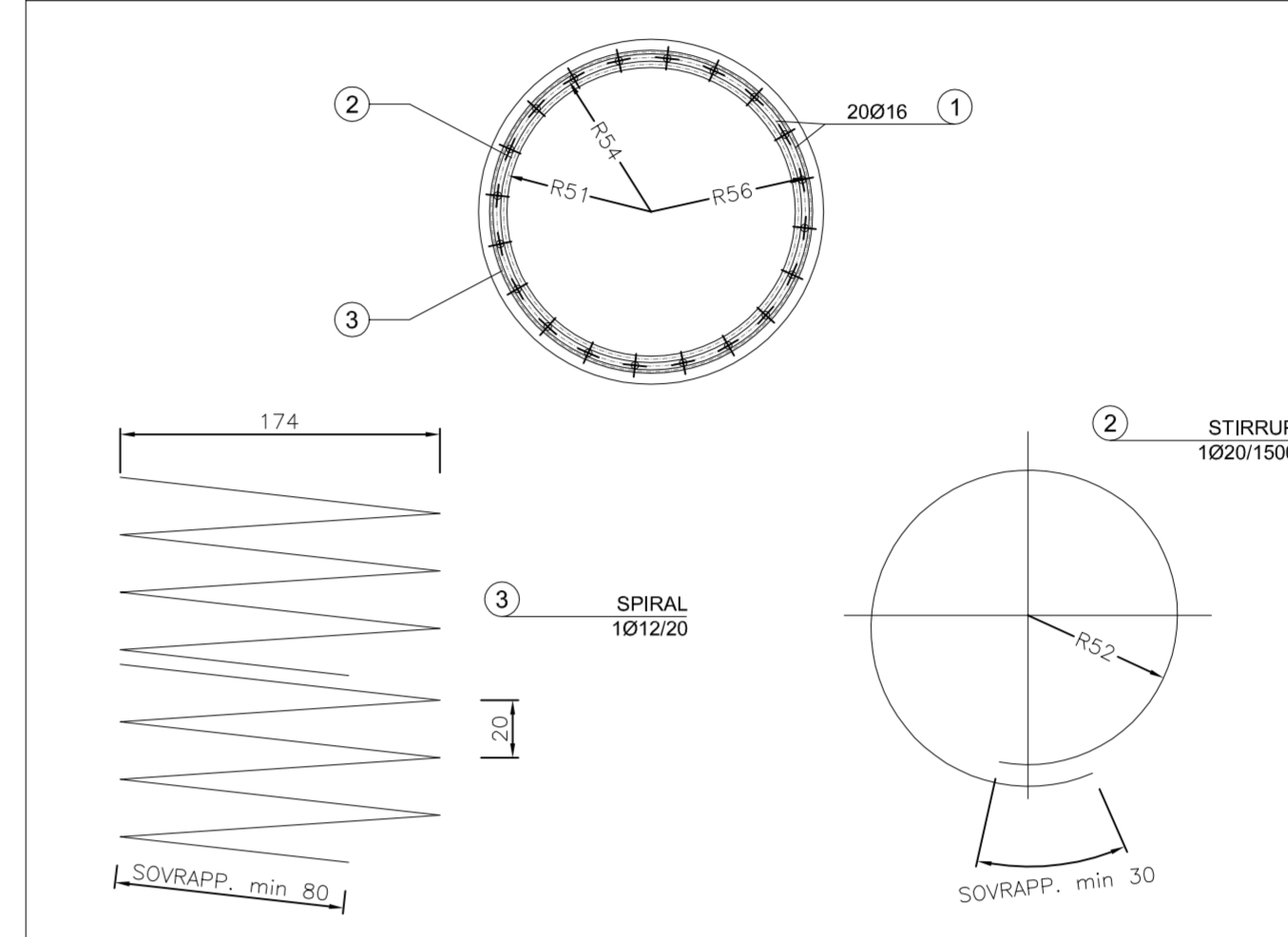

PILES WALL/PILA Ø1200/1.30m  
H=22.00m

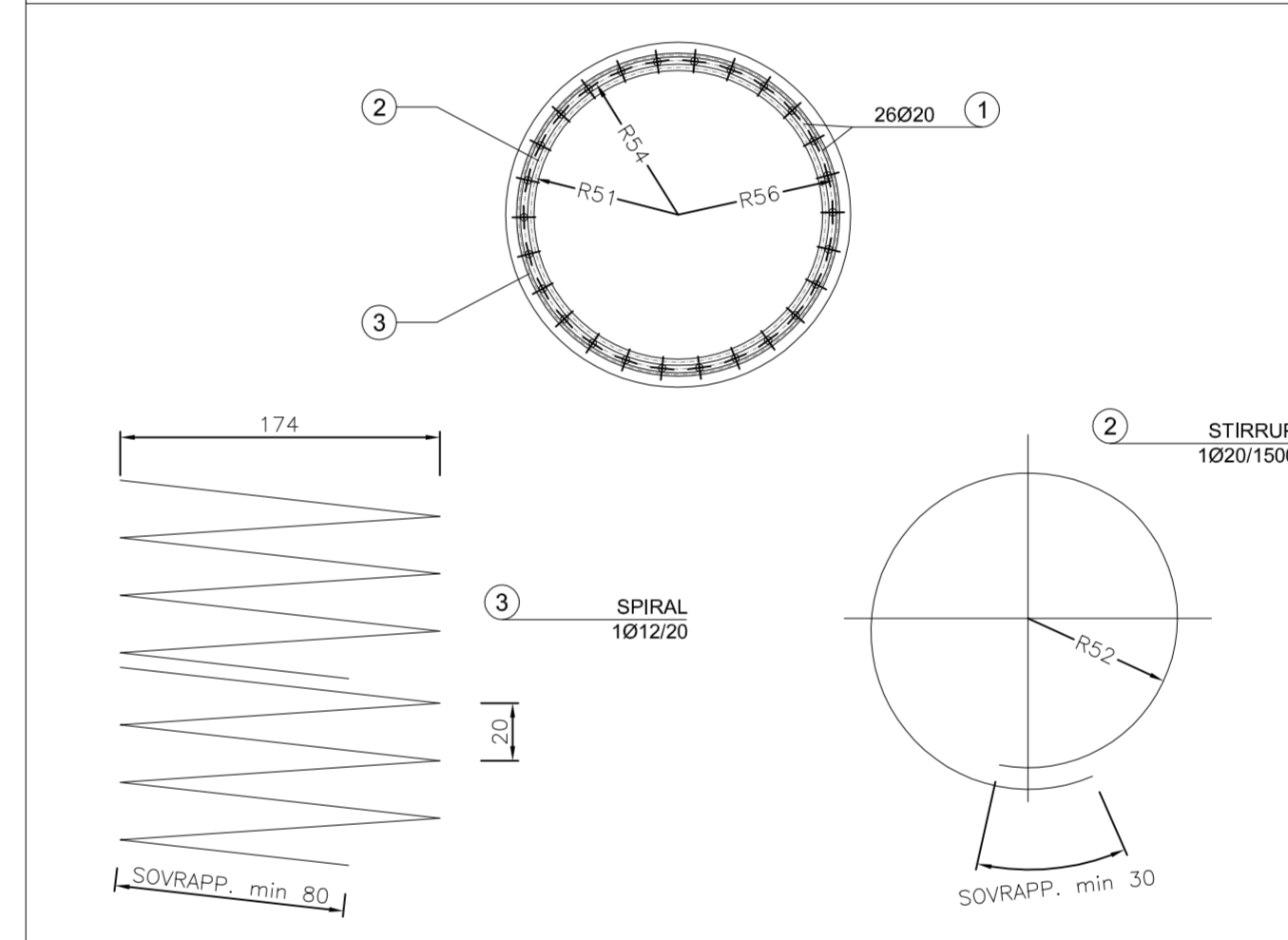

PILES WALL/PILA Ø1200/1.30m  
H=25.00m

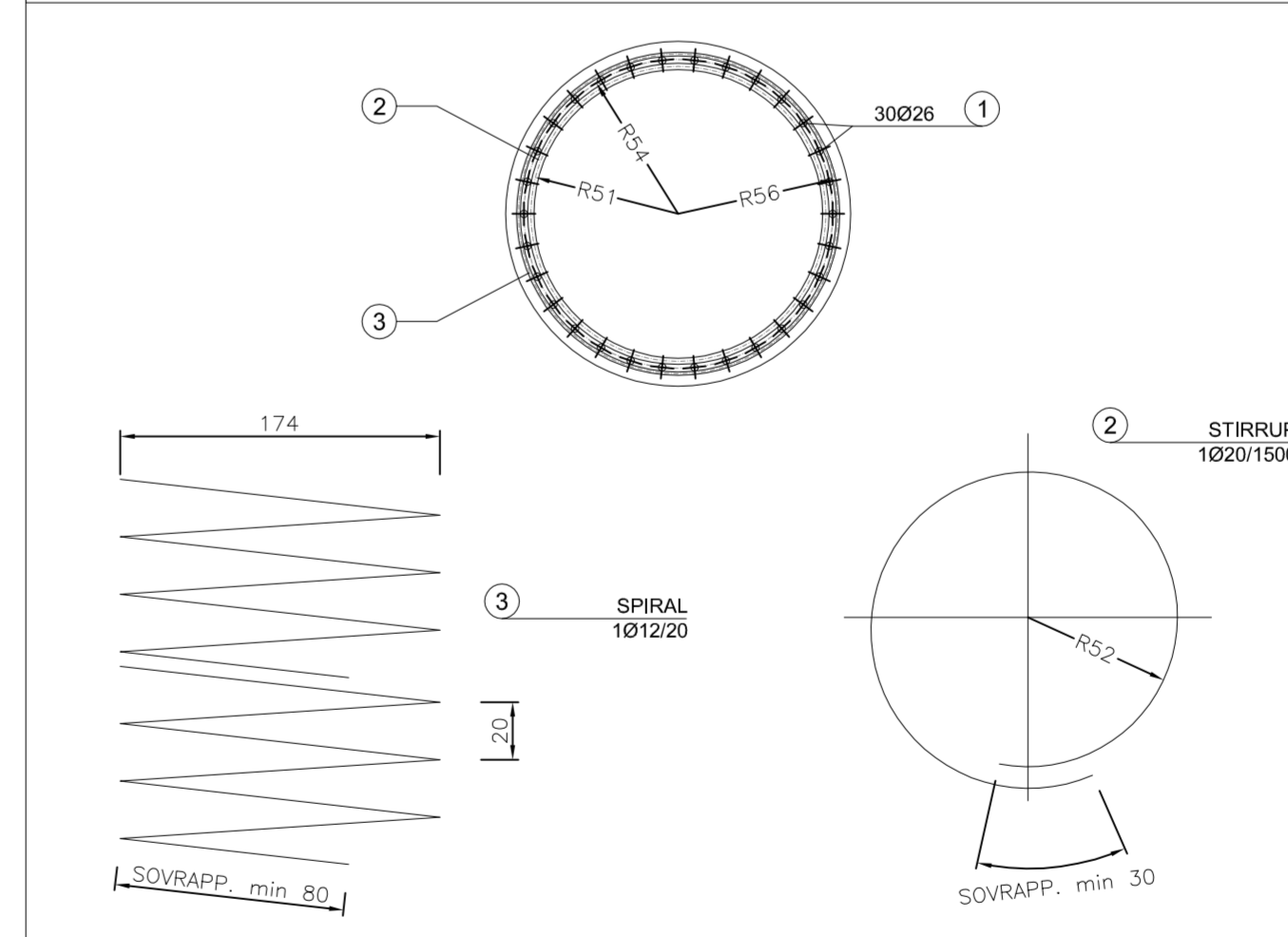

PILES WALL/PILA Ø1200/1.30m  
H=28.00m

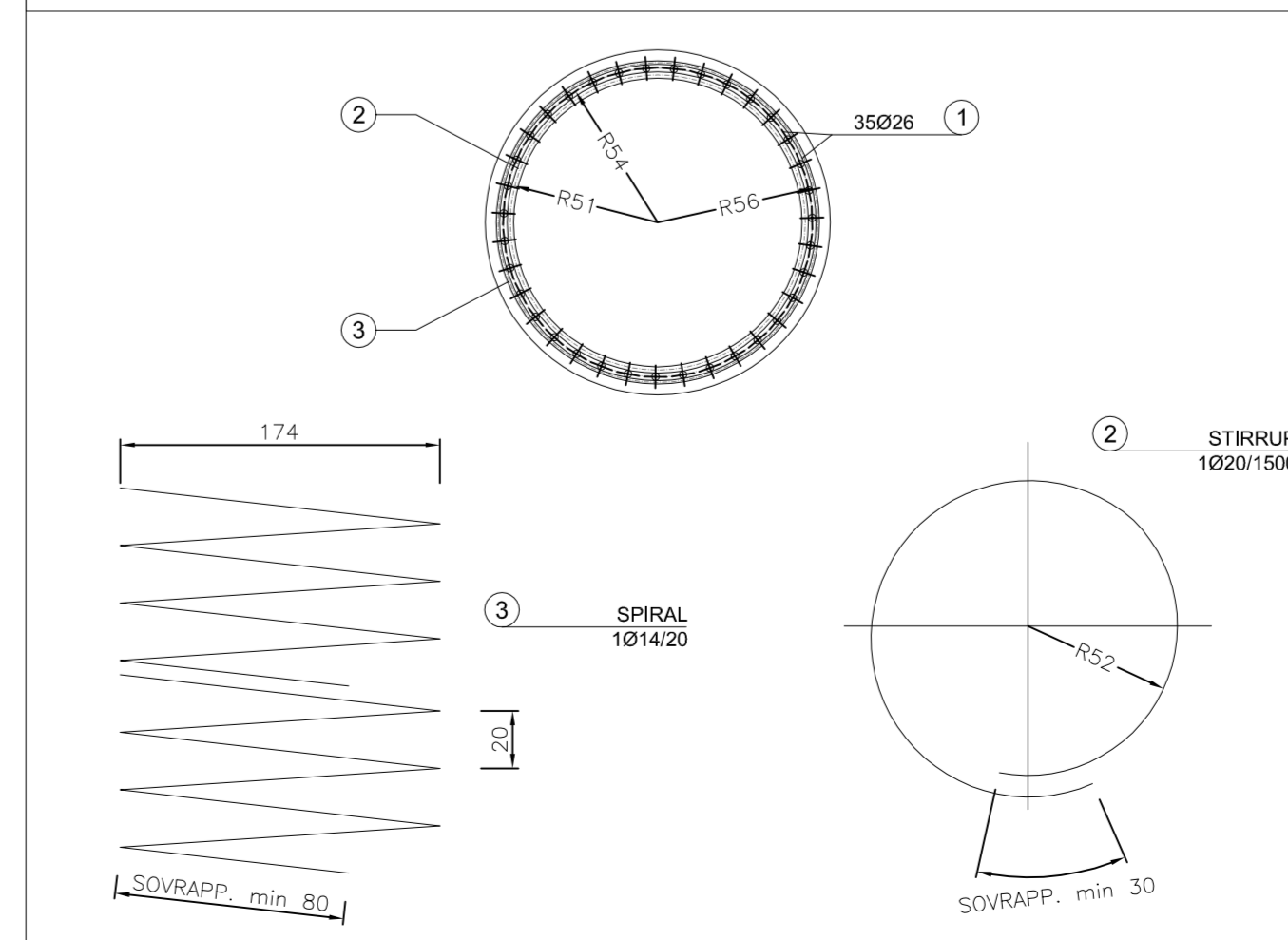

STEELS TABLE	
<b>REINFORCING STEEL:</b>	
- B450C (weldable)	
Bending diameter $d_{br} \geq$	
$\phi$ Bar $< \phi 20 \rightarrow d_{br} = 6\phi$	
$\phi$ Bar $\geq 20 \rightarrow d_{br} = 8\phi$	
<b>MATERIAL TABLE</b>	
<b>CONCRETE PILE:</b>	
- Type H2	
- $f_{ck} \geq 25$ MPa	
- Water/cement ratio $< 0.50$	
- Minimum structural Class S4/S5	
- Cement type CEM III/V	
- Class of chloride content Cl 0.20	
- $\phi$ max aggregate = 22.4 mm	
<b>CONCRETE CURB:</b>	
- Type H2	
- $f_{ck} \geq 25$ MPa	
- Water/cement ratio $< 0.50$	
- Minimum structural Class S4/S5	
- Cement type CEM III/V	
- Class of chloride content Cl 0.20	
- $\phi$ max aggregate = 22.4 mm	
<b>REINFORCING STEEL:</b>	
- B450C controlled by establishment	
- Weldable	
<b>LEAN CONCRETE:</b>	
- Type I	
- $f_{ck} \geq 12$ MPa	
- Cement type CEM I/V	

D					
C					
B					
A					

Index	Date	Modification/Revision	Projectant	Approved Consultant	Approved CFR



CONSULTANT / CONSULTANT		Date	Signature
Approved	Project manager		R. Liuzza
Approved	Coordinator/Section 1		C. Gambelli
Verified	Tunnel Expert		C. Gambelli
Checked	Tunnel Expert		C. Gambelli
Elaborated	Project Designer		C. Gambelli

SUBCONSULTANT / SUBCONSULTANT		Date	Signature
Approved	Responsible Subconsultant		
Elaborated	Project Designer		

Rehabilitarea liniei de cale ferata Brasov - Simeria, parte componenta a coridorului IV Pan European, pentru circulatia trenurilor cu viteza maxima de 160 km/h. Sectiunea 1 Brasov - Sighisoara

Rehabilitation of the railway line Brasov - Simeria, component Part of the IV Pan-European Corridor, for the trains circulation with maximum speed of 160 km/h. Section 1 Brasov - Sighisoara

Denumire desen / Drawing Title:		ARCHITA 2 TUNEL	
Entrance concrete pile wall		ENTRANCE ARCHITA SIDE	
Codificare / Codification System:		Scara / Scale: variat / various	
Lot:		Nr. / No: .	

E	A	5	1	0	1	C	1	4	B	2	G	A	0	9	0	0	0	0	2	0
---	---	---	---	---	---	---	---	---	---	---	---	---	---	---	---	---	---	---	---	---