

SECTION C-C
SECTIUNEA CURENTA C-C
Scale/Scara 1:50

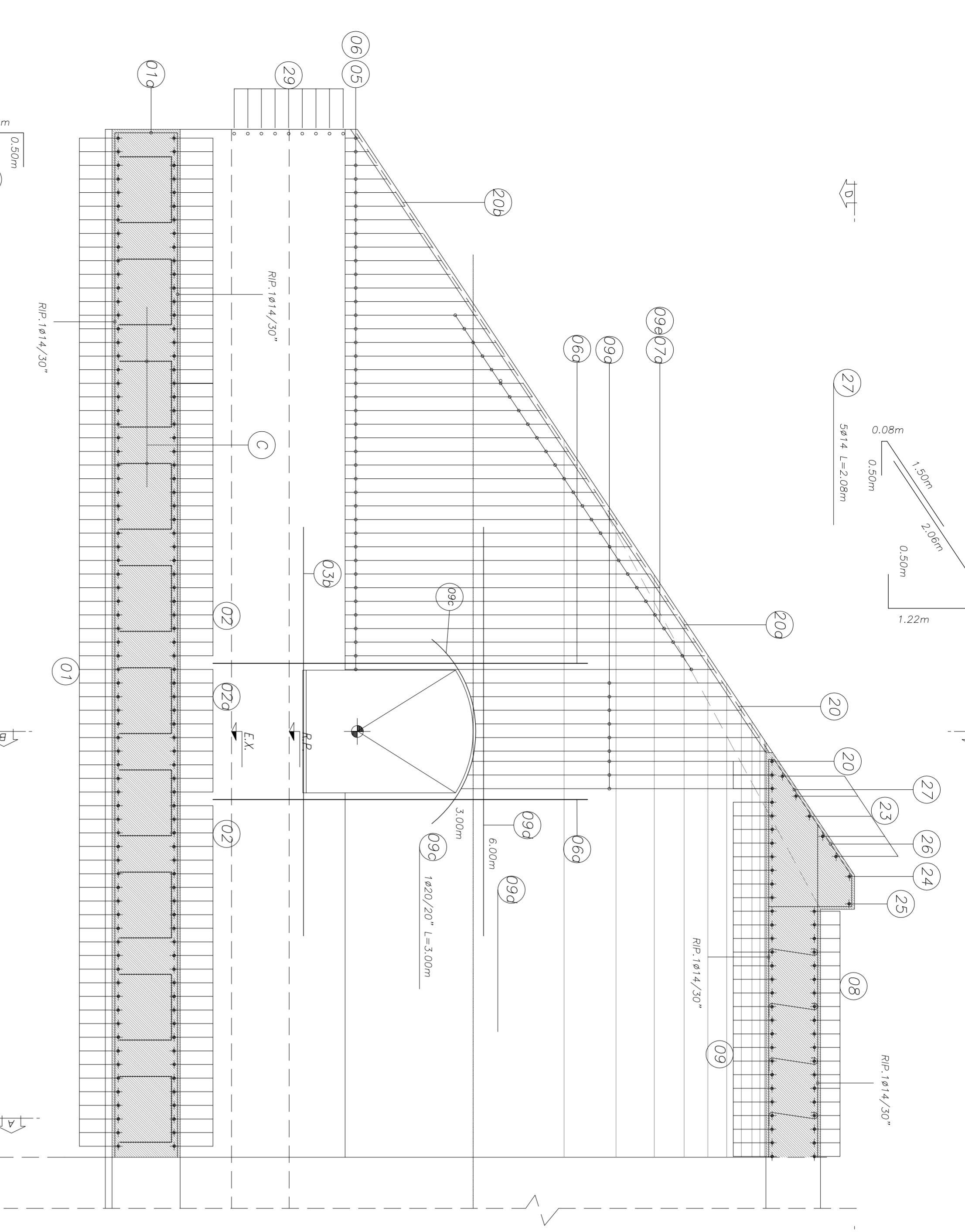

SECTION WITH SHELTER STAFF NICHE B-B
SECTIUNEA CU NISE PENTRU ADAPOSTUL PERSONALULUI B-B
Scale/Scara 1:50

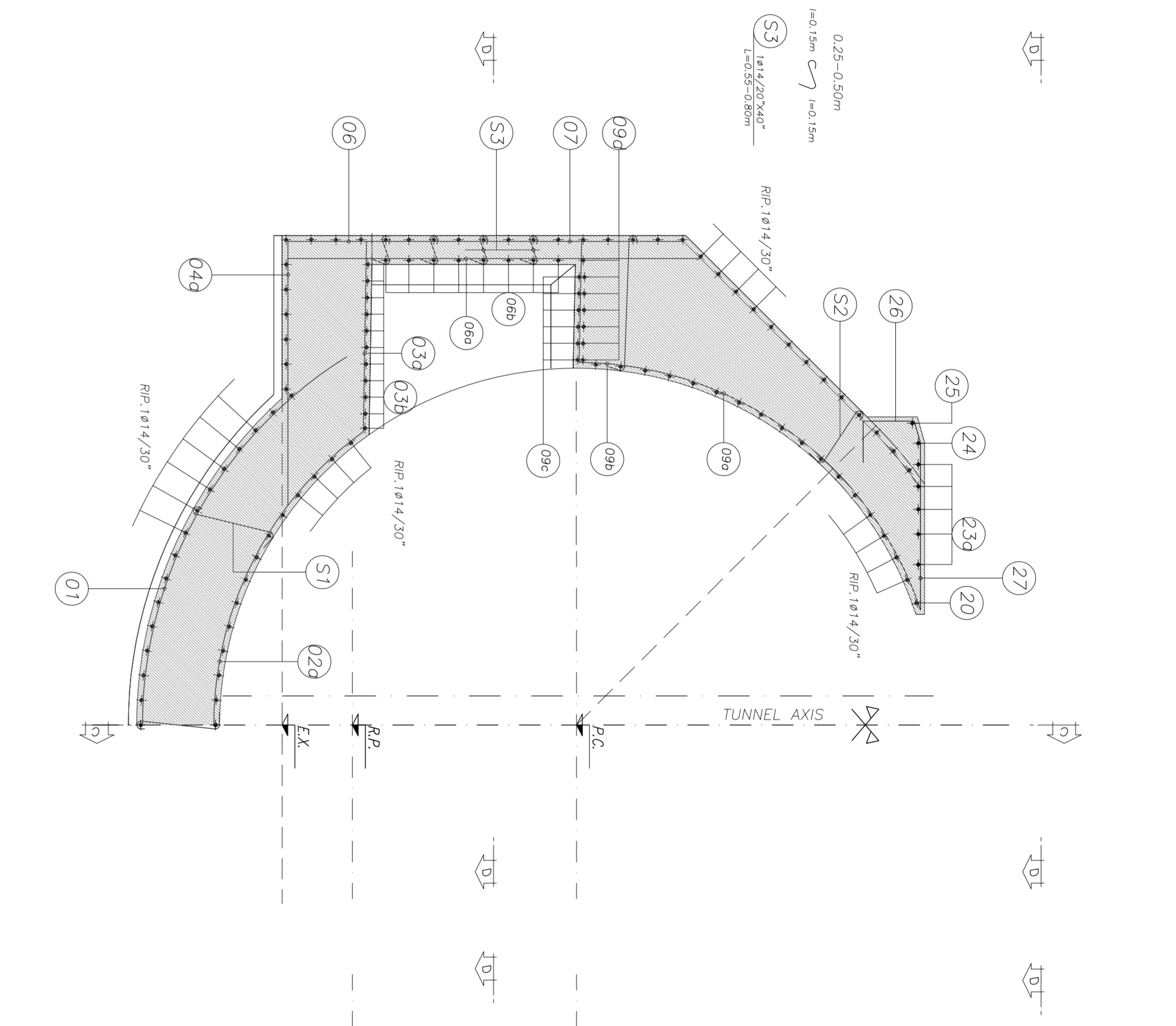

CURRENT SECTION A-A
SECTIUNEA CURENTA A-A
REINFORCEMENTS
ARMATURA
Scale/Scara 1:50

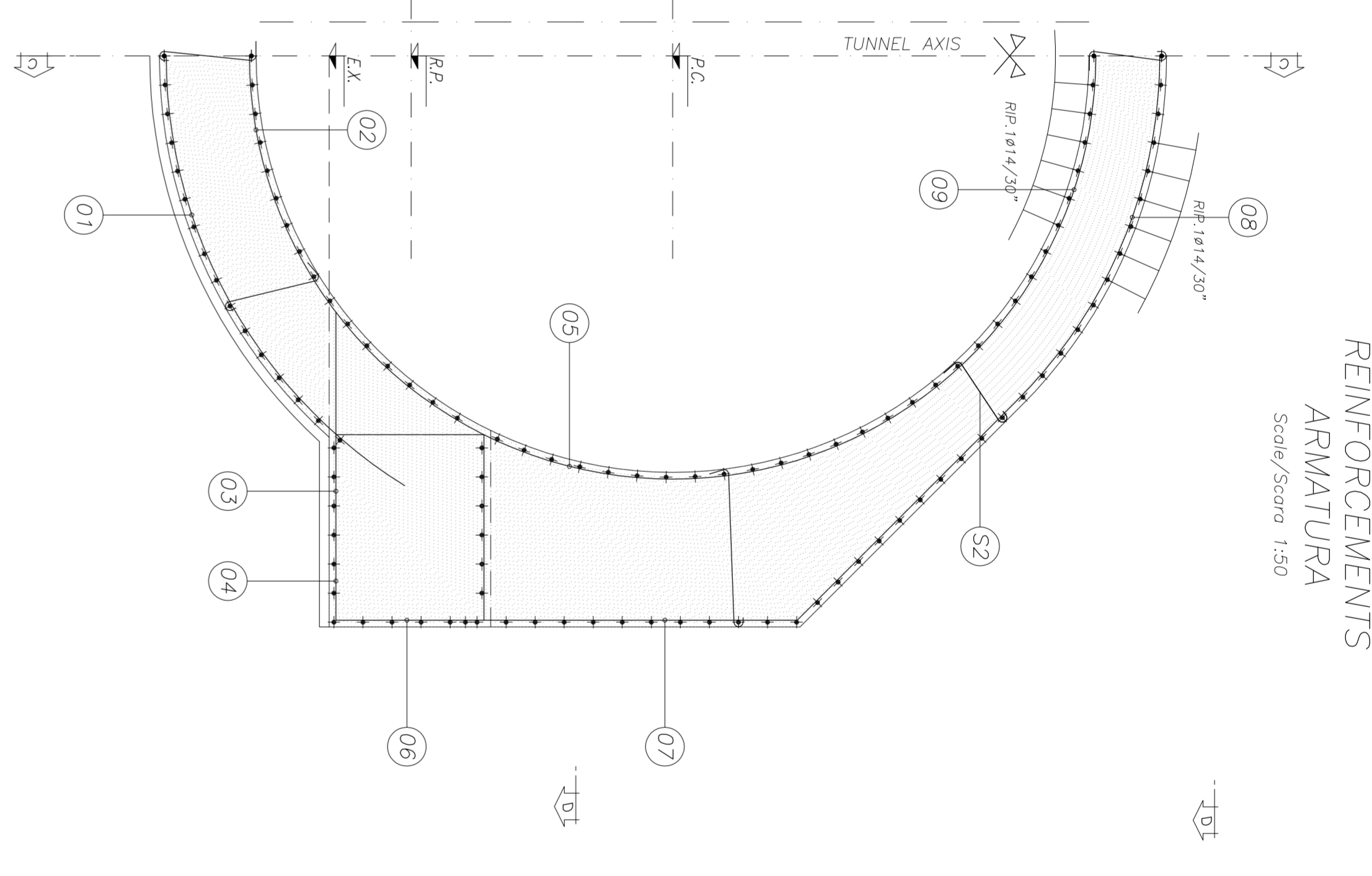

SECTION D-D
SECTIUNEA CURENTA D-D
Scale/Scara 1:50

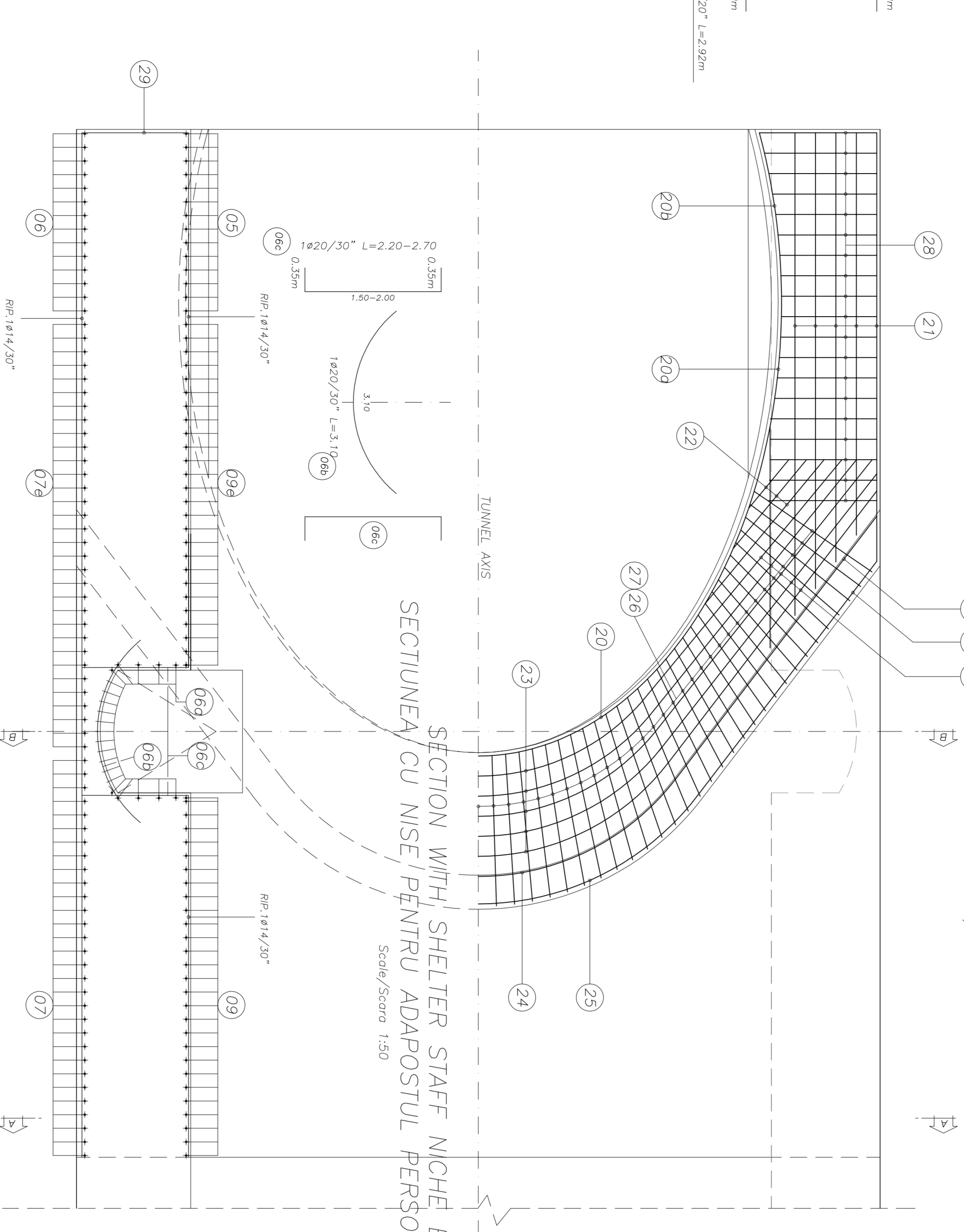

SECTION WITH SHELTER STAFF NICHE E-E
SECTIUNEA CU NISE PENTRU ADAPOSTUL PERSONALULUI E-E
Scale/Scara 1:50

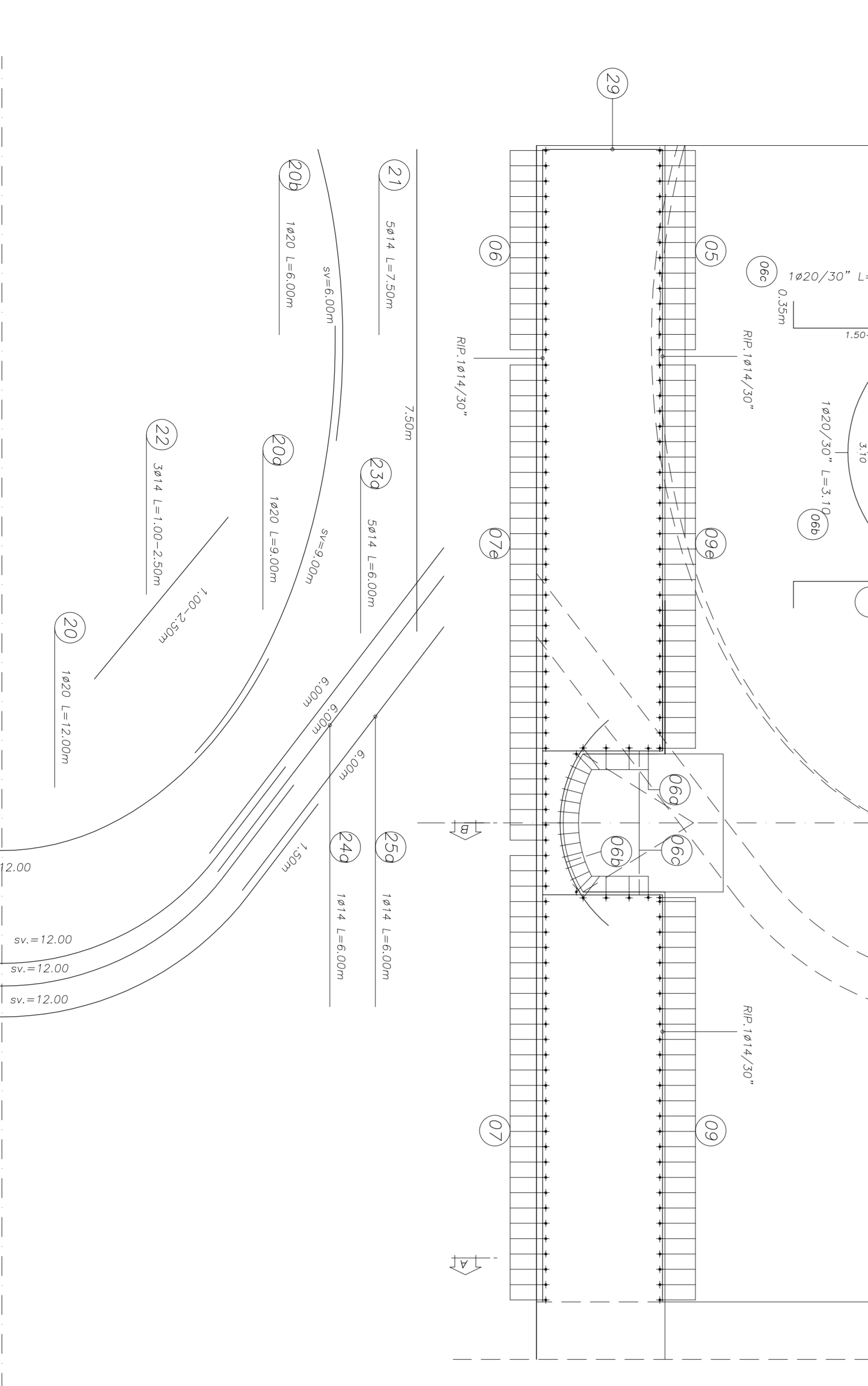

STEELS TABLE

Legend measures:

REINFORCING STEEL:
- B500C (weldable)
Binding diameter ϕ_{br} :
 ϕ Bar $\leq \phi 20 \rightarrow \phi_{br} = \phi$
 ϕ Bar $\phi 20 - \phi 25 \rightarrow \phi_{br} = 8\phi$

MATERIAL TABLE

TUNNEL LAYER CONCRETE:

- Type C2
- $f_{ck} \geq 20$ MPa
- $f_{ctm} \geq 2.0$ MPa
- Minimum structural class S3/S4
- Exposure class related to environmental conditions: MX2
- Concrete cover related to reinforcement: $c_{min} = 40$ mm
- Class of durable content: C 0.20
- ϕ max aggregate = 32 mm

TUNNEL LAYER CONCRETE:

- Type C1
- $f_{ck} \geq 15$ MPa
- $f_{ctm} \geq 1.5$ MPa
- Minimum structural class S3/S4
- Exposure class related to environmental conditions: MX2
- Concrete cover related to reinforcement: $c_{min} = 40$ mm
- Class of durable content: C 0.20
- ϕ max aggregate = 32 mm

REINFORCING STEEL:

- B500C covered by endorsement
- Weldable

LEAF CONCRETE:

- Type C1
- $f_{ck} \geq 15$ MPa
- $f_{ctm} \geq 1.5$ MPa
- Concrete cover: $c_{min} = 40$ mm

LEGEND

RP = REFERENCE PLANE
EX = EXCAVATIONS PLANE
PC = CENTERS PLANE

Index	DATA	Modificator	Proprietar	Adnotat	Adnotat
A	DATE	Modificator	Proprietar	Adnotat	Adnotat
B					
C					
D					

GUVERNUL ROMÂNIEI
ROMANIAN GOVERNMENT

PROIECT FINANȚAT DE UNIUNEA EUROPEANĂ
EUROPEAN UNION FINANCED PROJECT

CLIENT / CLIENT

CONSULTANT / CONSULTANT

SUBCONSULTANT / SUBCONSULTANT

Demnitate desen / Drawing Title :
HOMOROD TUNNEL
Tunel de tranșă în tunel amenajat
Perennial of tranche in tunnel amenajment

Proiect/Proiect
2024/03/07/2025/03/07
Faza / Phase:
P1.111 / P1.11

Scale/Scara: 1:50

Verificat / Various: Sava / Sava

U07

Nr. / No: 0