

STEEL RIBS TYPE 2 IPE 180
NERVURI DIN OTEL TIP 2 IPE 180
Scale/Scara 1:20

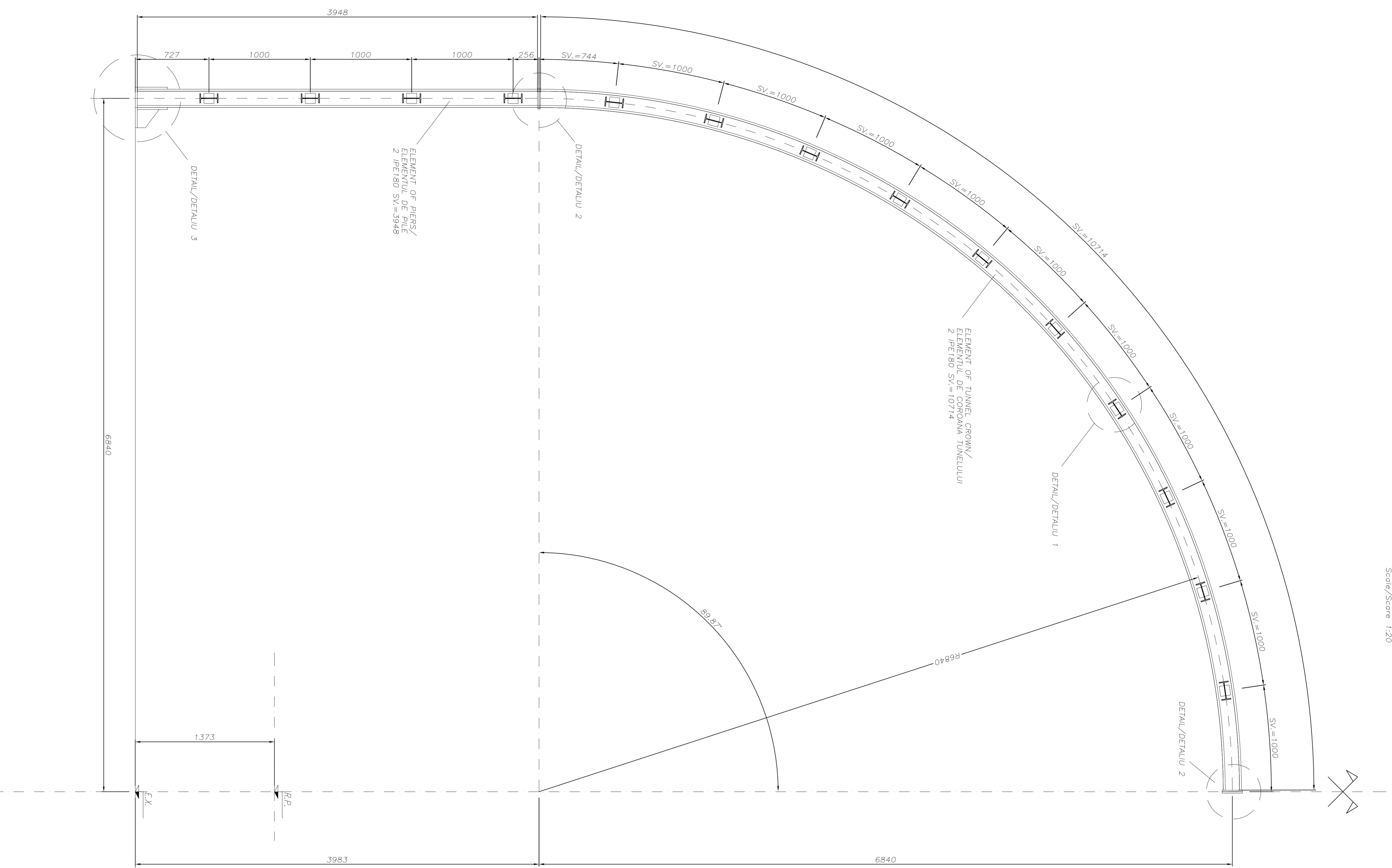

DETAIL "1"
DETALIU "1"
Scale/Scara 1:5

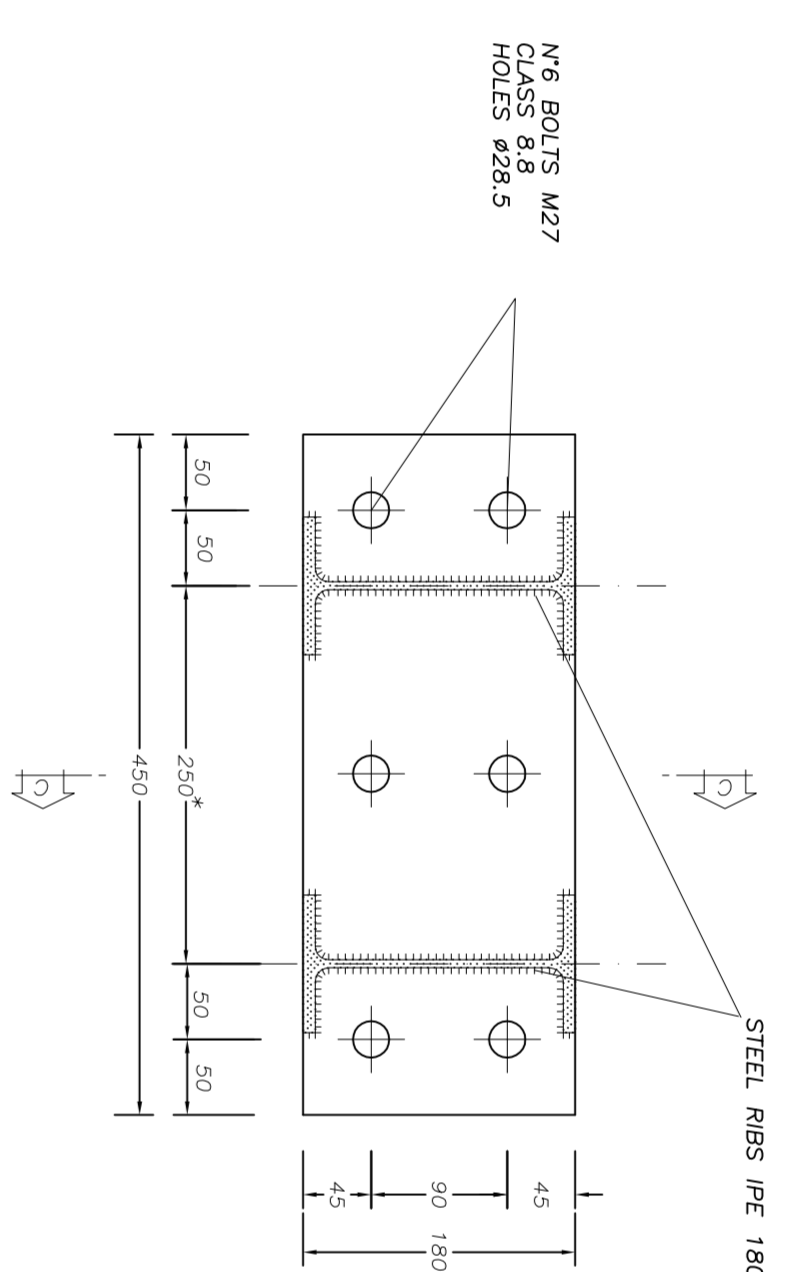

SECTION A-A
SECTIUNI A-A
Scale/Scara 1:5

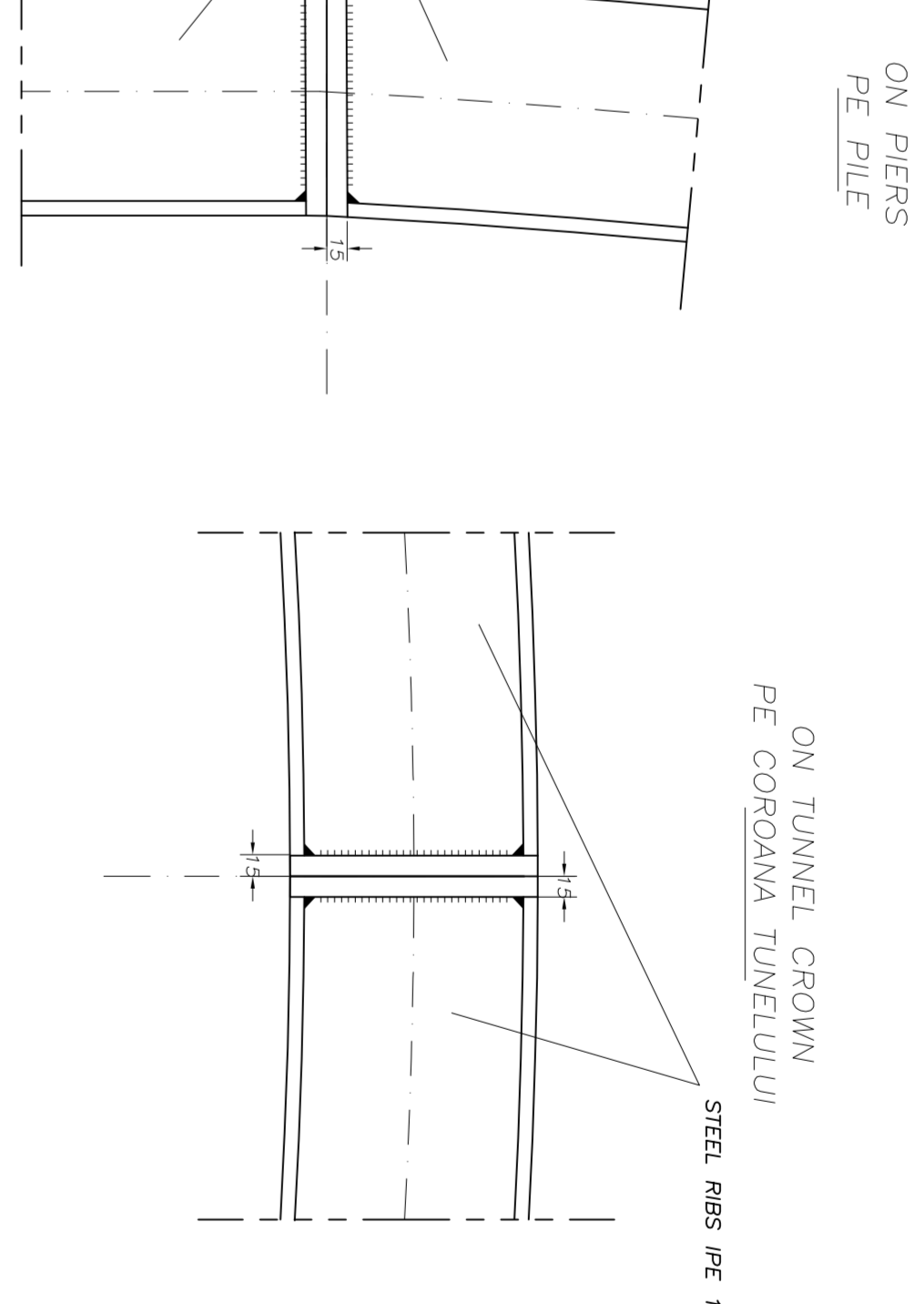

DETAIL "2"
DETALIU "2"
Scale/Scara 1:5

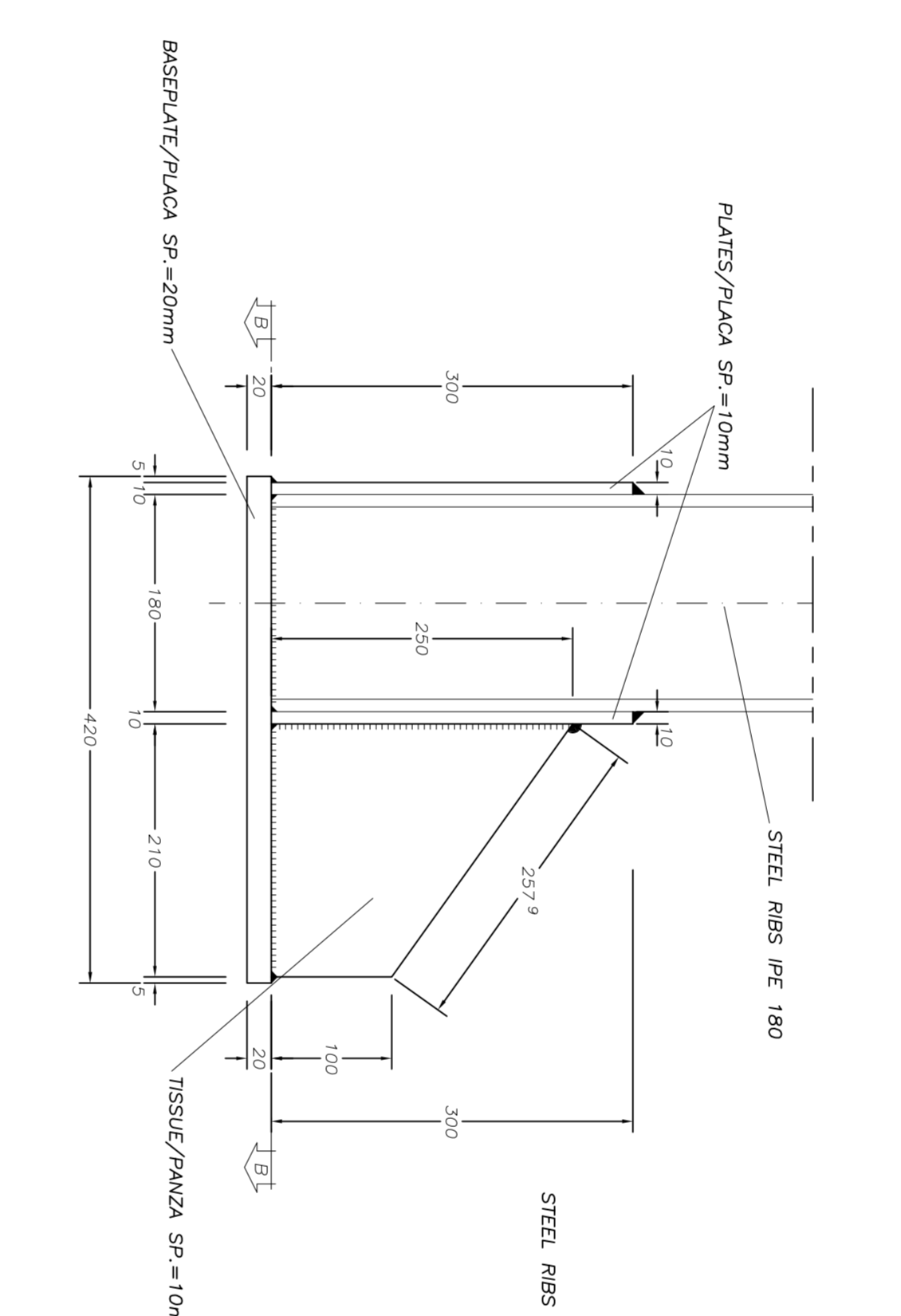

SECTION B-B
SECTIUNI B-B
Scale/Scara 1:5

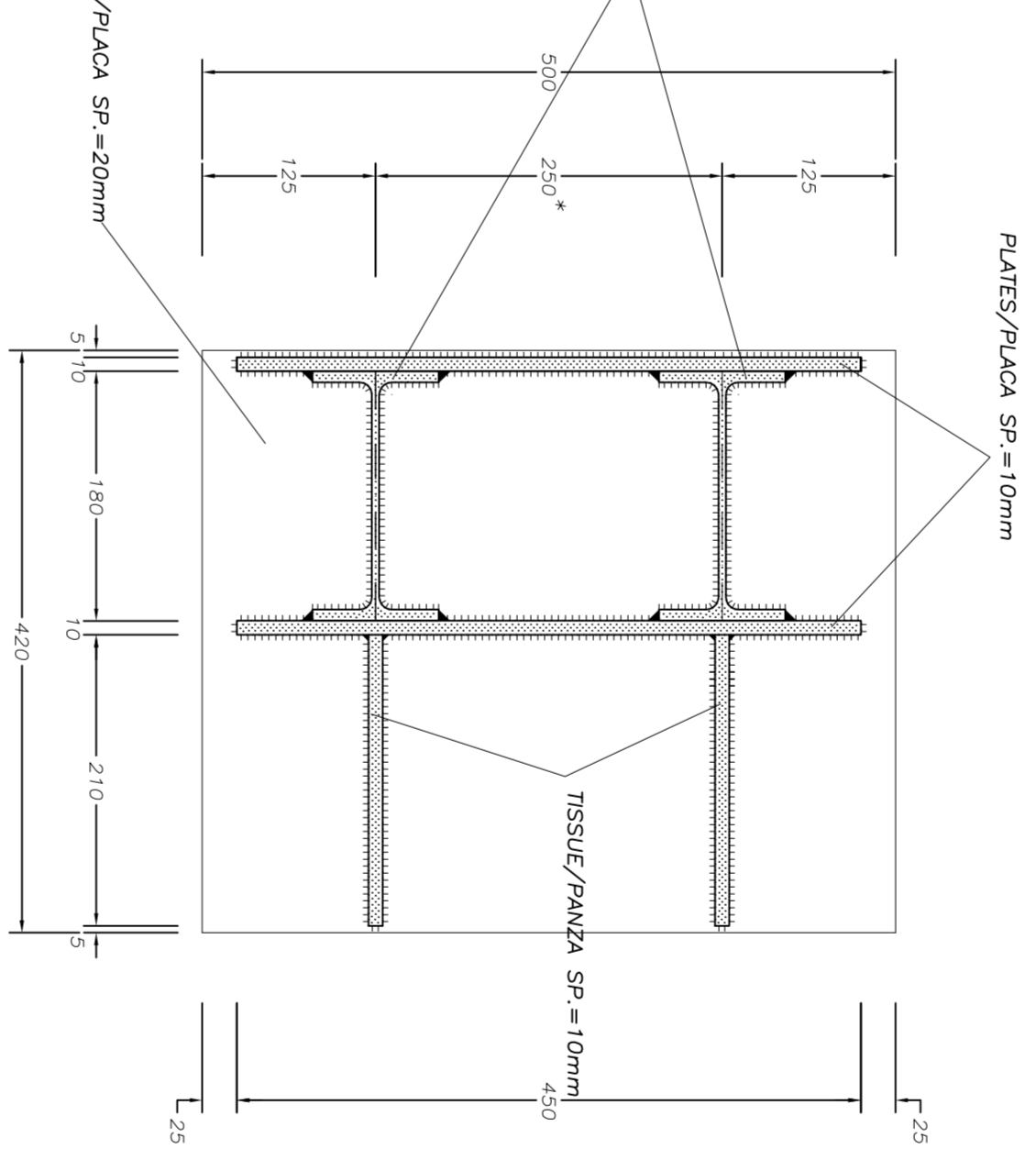

DETAIL "3"
DETALIU "3"
Scale/Scara 1:5

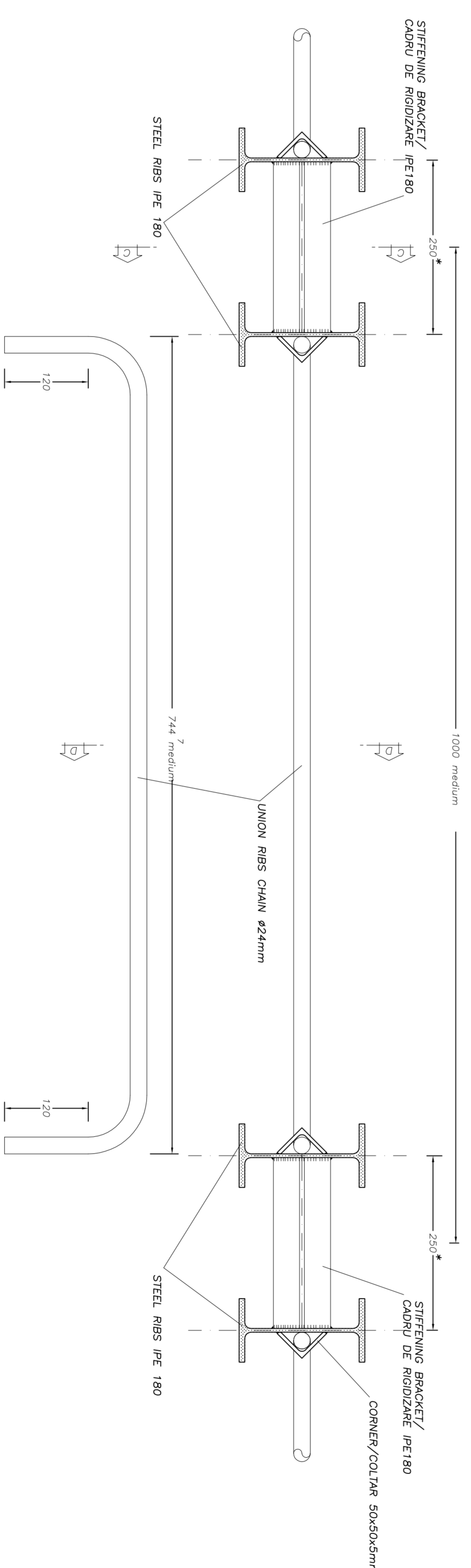

SECTION C-C
SECTIUNI C-C
Scale/Scara 1:5

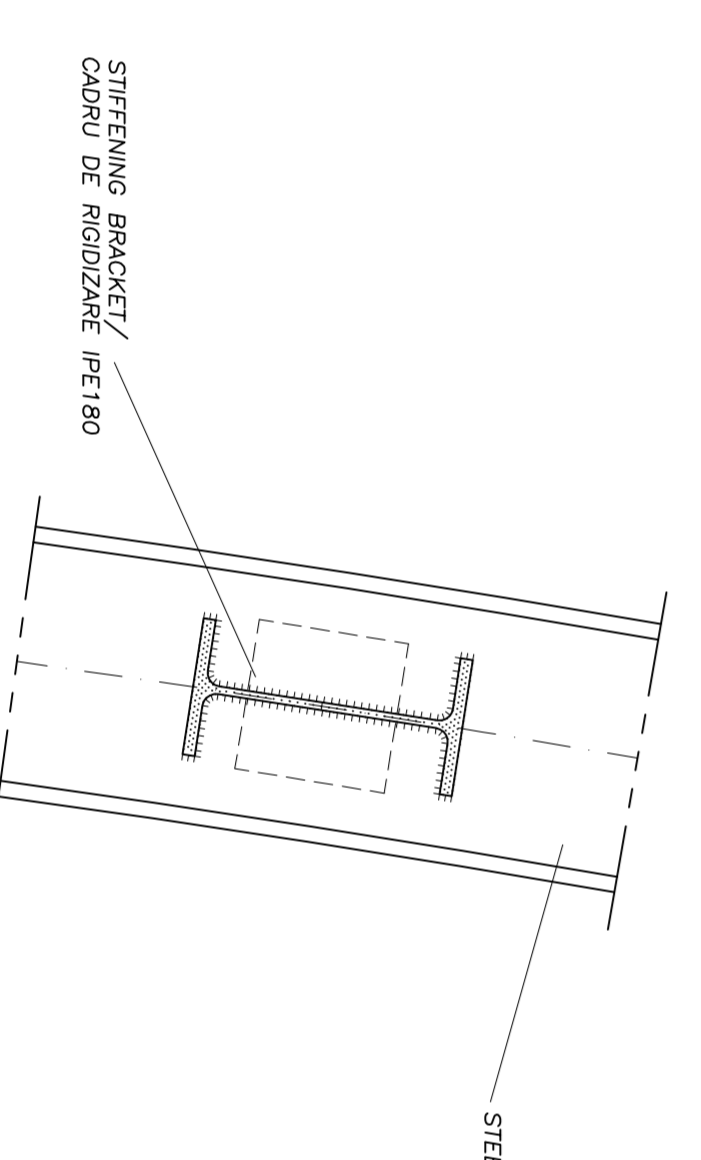

SECTION D-D
SECTIUNI D-D
Scale/Scara 1:5

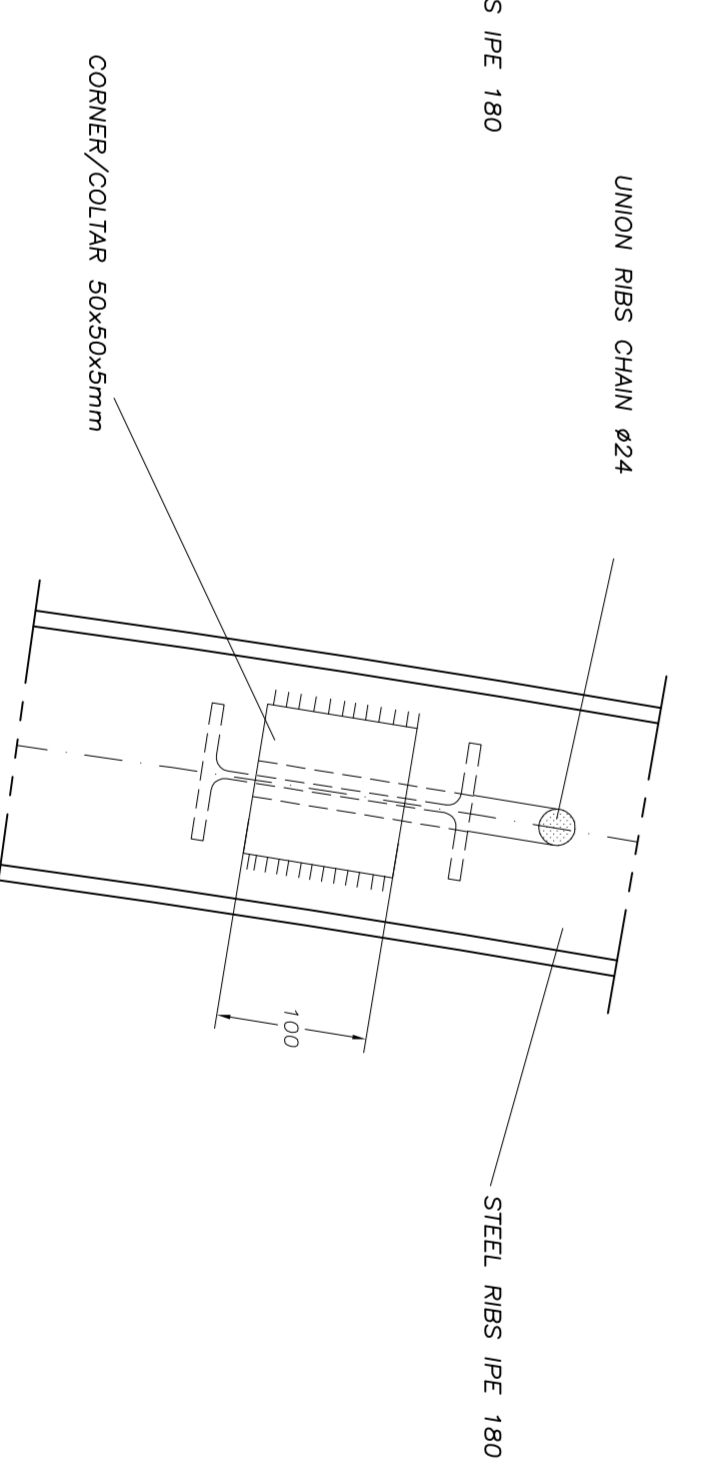

MATERIAL TABLE

REBRS, PLATE, STRENGTHING, BRACKET, CORNER :
- S 275 430 Wf9
- S 275 430 Wf9
- S 275 430 Wf9
- S 275 430 Wf9
- S 275 430 Wf9
- B450C controlled by establishment
- Weldable

MATERIAL TABLE

INSULATA DE OTEL, SECTIUNI CURELATE, CADRUL DE RINZORIRE, UNGHURE :
- S 275 430 Wf9
- S 275 430 Wf9
- S 275 430 Wf9
- S 275 430 Wf9
- S 275 430 Wf9
- B450C controlled by core unitate
- Sudabil

LEGEND
RP = REFERENCE PLANE
EX = EXCAVATIONS PLANE
PC = CENTERS PLANE

Index	Date	Modificari/Modifications	Proiectant/Designer	Verificator/Checker	Acordat/Approved
A					
B					
C					
D					

CLIENT / CLIENT
CFR
C.N.C.F. "C.F.R." S.A.

CONSULTANT / CONSULTANT
TECNIC
CONSULTING ENGINEERS

SUBCONSULTANT / SUBCONSULTANT
MURENII TUNNEL

Project/Proiect
2044630/16/974002
Faza / Phase:
P.I.N. / I.D.

Conditiuni / Conditions System	Scara / Scale	Lot	Nr. / No.
E A 5 1	0 1	C	1 6
B B	G A	1 1	0 0
0 0 2	0	0	0