

SECTIUNE TRANSVERSALA / CROSS SECTION

Scara 1:100

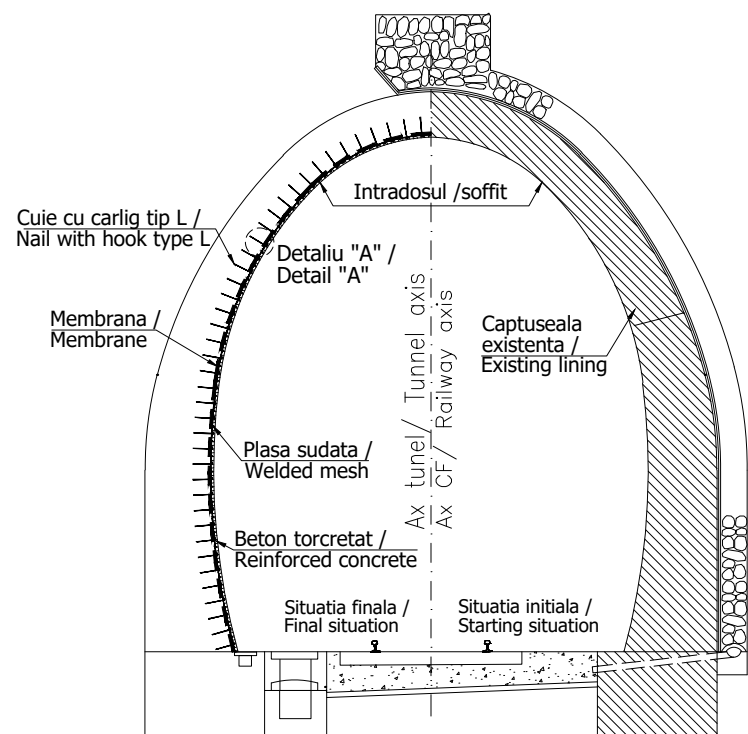

Nota 1:
Hidroizolarea la intrados a zonelor cu infiltrati cu o membrana de 2-3 mm grosime aplicata prin pulverizare, protejata cu un beton torcretat de 4-5 cm grosime.
Inainte de aplicarea hidroizolatiei, se da jos torcretul existent de pe intradosul tunelului, se curata suprafata si se injecteaza eventualele fisuri.

Note 1:
Waterproofing on the soffit area with infiltrates with a membrane of 2-3 mm thickness applied through spray, protected with a shotcrete of 4-5 cm thick.
Before application waterproofing, it comes down the existing shot from the underside of the tunnel, clean the surface and inject any cracks.

Sectione 1-1 / Section 1-1

Scara 1:5

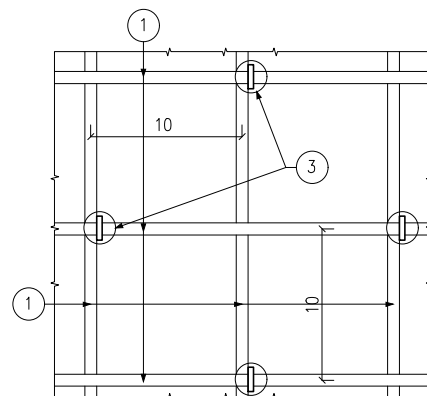

LEGENDA / LEGEND

- ① Plasa sudata 8 mm, ochiuri 100x100mm / Welded mesh 8 mm, mesh 100x100mm
- ② Membrana 2-3 mm grosime / Membrane 2-3 mm thick
- ③ Cuie cu carlig tip L / Nail with hook type L
- ④ Beton torcretat 4-5 cm grosime / Reinforced concrete 4-5 cm thick
- ⑤ Captuseala din beton armat / Lining reinforced concrete

Detaliu "B" / Detail "B"

Scara 1:2

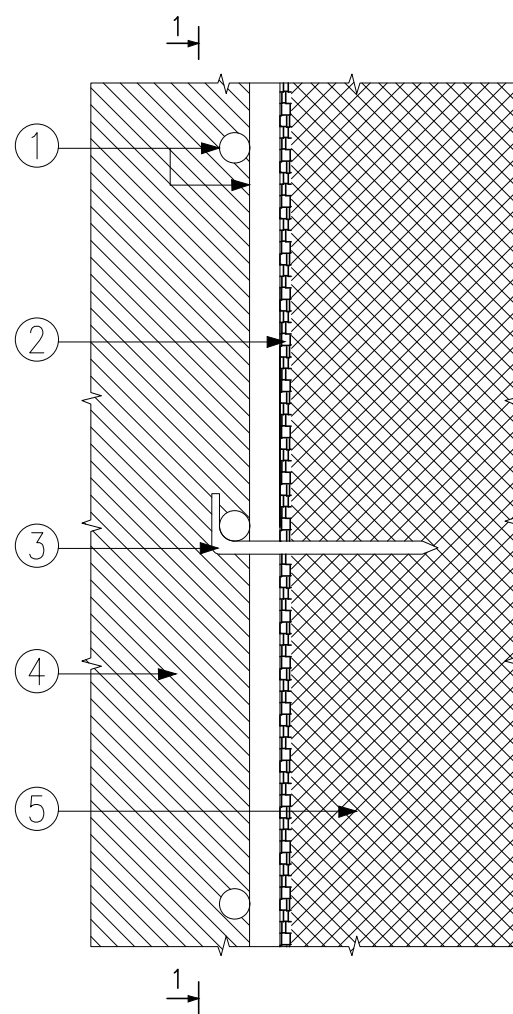

Nota 2:
Acest tip de interventie se aplica pentru urmatuare tuneluri: MOSU, BAHNA, FENES.

Note 2:
This type of intervention applies to the following tunnels: MOSU, BAHNA, FENES.



CLIENT / CLIENT

C.N.C.F. "C.F.R." - S.A.



CONSULTANT / CONSULTANT

Faza / Phase	Positia / Position	Nume / Name	Data / Date	Semnatura / Signature
Aprobat / Approved	Manager de Proiect / Project Manager	Sergio MENICHINI	10.2020	
Verificat / Checked	Expert Cheie / Key Expert	Lorenzo SABINI	10.2020	
Întocmit / Elaborated	Proiectant / Designer	Rosario RUSSO	10.2020	

SUBCONSULTANT / SUBCONSULTANT

Aprobat / Approved	Responsabil Subconsultant / Subconsultant Responsible			
Întocmit / Elaborated	Proiectant / Designer			

Studiu de Fezabilitate pentru Reabilitarea liniei feroviare Craiova - Drobeta Turnu Severin - Caransebes, parte a Coridorului Orient/Est Mediteranean - Feasibility Study For The Rehabilitation Of The Railway Line Craiova - Caransebes

Proiect/Project
74 / 2018
Faza/Phase
S.F.

Denumire / Title :

Lucrari de reabilitare ale tunelurilor - solutie pentru hidroizolatie

Tunnel rehabilitation works - solution for waterproofing

Codificare / Codification System

E 2 1 8 0 S F 0 0 W Z T U 0 0 0 0 0 2 A

Istoricul reviziilor / Revision History

Rev.	Data/Date	Descriere Modificare / Modification description
1		
2		
3		
4		

Responsabilitatea privind această publicație revine integral autorului. Uniunea Europeană nu este responsabilă pentru modul în care sunt utilizate informațiile publicate.

The contents of this publication are the sole responsibility of (name of the implementing partner) and do not necessarily reflect the opinion of the European Union.