

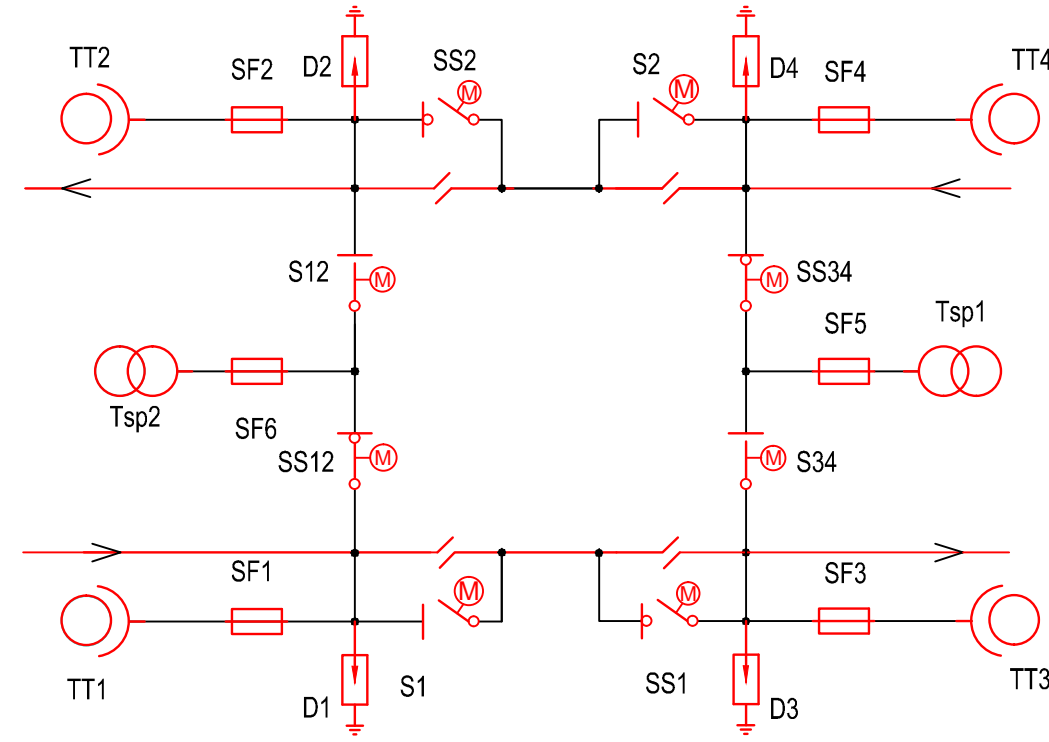

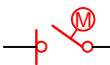

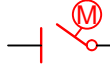

POST de SECTIONARE - LINIE DUBLA
DOUBLE TRACK - SECTIONNING POST



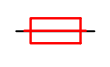
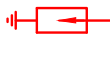

Legenda/Legend

-  Separator de sarcina de exterior, deschidere vizibila
Outdoor single-phase switch - visible opening
-  Separator monopolar de exterior actionat cu motor
Outdoor single-phase disconnect, motor-operated
-  Transformator de putere
Power transformer
-  Transformator de tensiune
Voltage transformer
-  Siguranta fuzibila
Fuse
-  Descarcator cu ZnO
ZnO surge arrester
-  Lama de aer
Insulating overlap







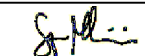

CLIENT / CLIENT **C.N.C.F. "C.F.R." - S.A.**

CONSULTANT / CONSULTANT

Faza Phase	Positia Position	Nume Name	Data Date	Semnatura Signature
Aprobat Approved	Manager de Proiect Project Manager	Sergio MENICHINI	05.2020	
Verificat Checked	Expert Cheie Key Expert	Cristina Spack	05.2020	
Întocmit Elaborated	Proiectant Designer	Mihaela Jigau	05.2020	

SUBCONSULTANT / SUBCONSULTANT

Aprobat Approved	Responsabil Subconsultant Subconsultant Responsible			
Întocmit Elaborated	Proiectant Designer			

Studiu de Fezabilitate pentru Reabilitarea liniei feroviare Craiova - Drobeta Turnu Severin - Caransebes, parte a Coridorului Orient/Est Mediteranean - Feasibility Study For The Rehabilitation Of The Railway Line Craiova - Caransebes

Proiect/Project
74 / 2018
Faza/Phase
S.F.

Denumire / Title :

**POST DE SECȚIONARE LINIE DUBLA / DOUBLE LINE-SECTIONING POST
SCHEMA ELECTRICĂ A POSTULUI DE SECȚIONARE
ELECTRICAL DIAGRAM FOR SECTIONING POST**

Codificare / Codification System

E	2	1	8	0	S	F	0	0	D	X	E	G	3	0	0	0	0	7	0
---	---	---	---	---	---	---	---	---	---	---	---	---	---	---	---	---	---	---	---

Istoricul reviziilor / Revision History

Rev.	Data/Date	Descriere Modificare / Modification description
1		
2		
3		
4		

Responsabilitatea privind această publicație revine integral autorului. Uniunea Europeană nu este responsabilă pentru modul în care sunt utilizate informațiile publicate.
The contents of this publication are the sole responsibility of (name of the implementing partner) and do not necessarily reflect the opinion of the European Union.