

OCC Craiova

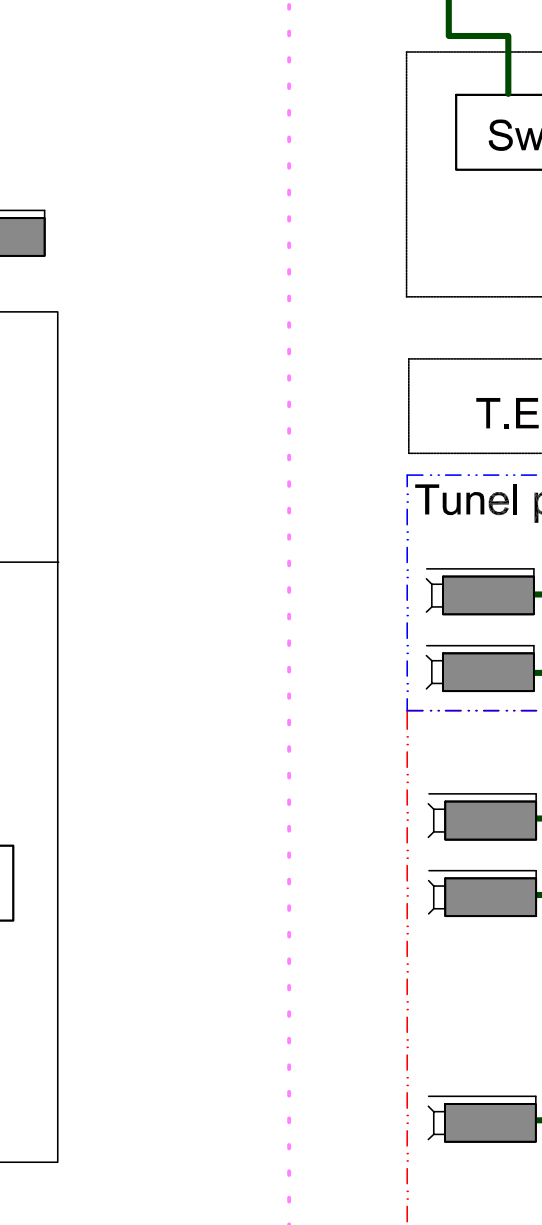

LINIE CURENTA

STATIE

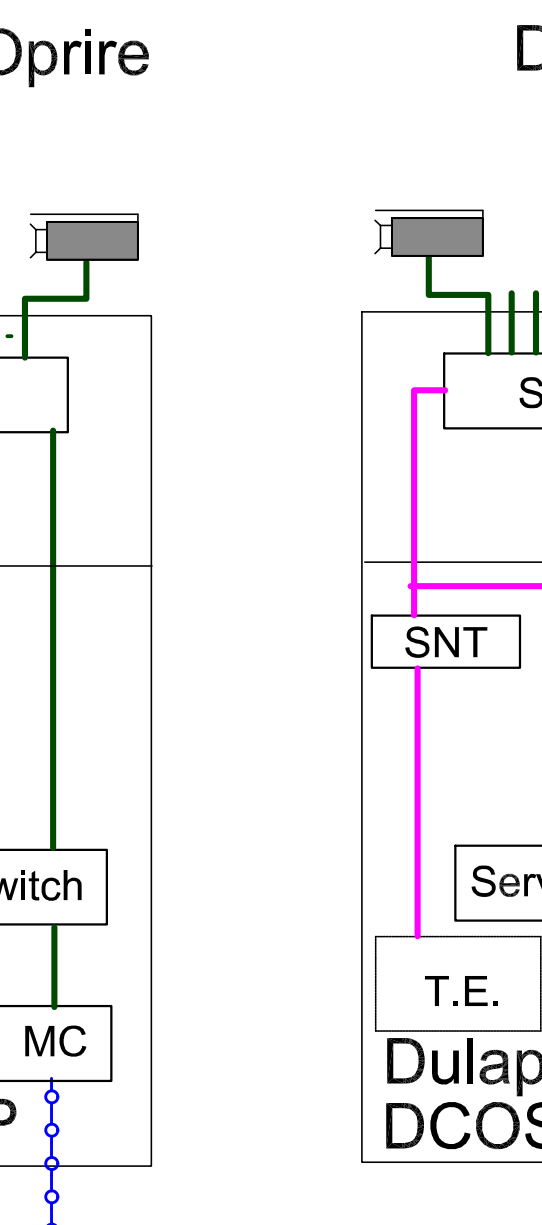
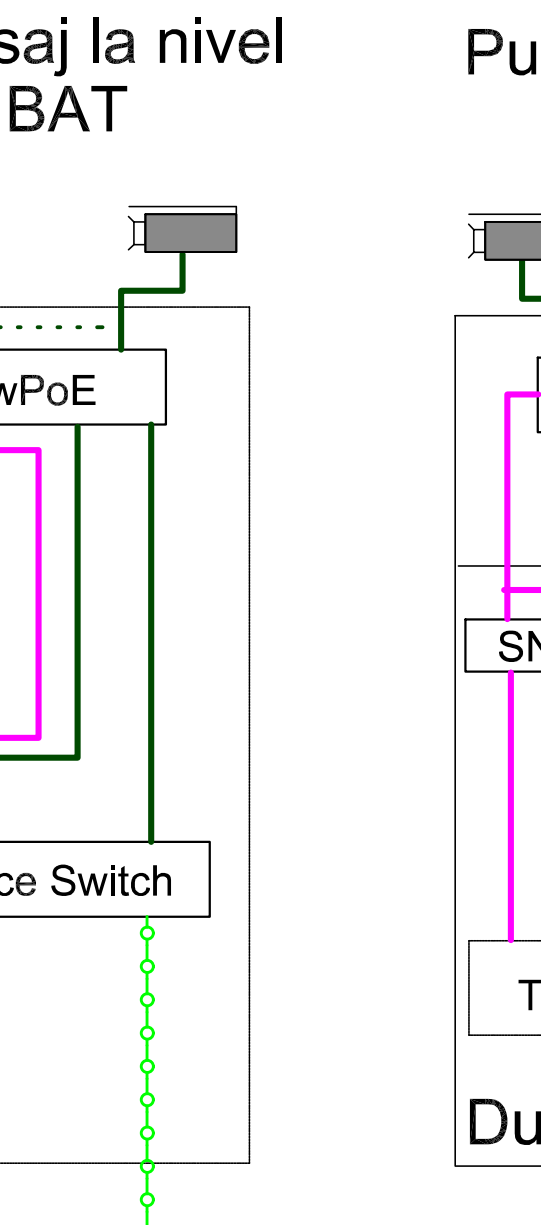
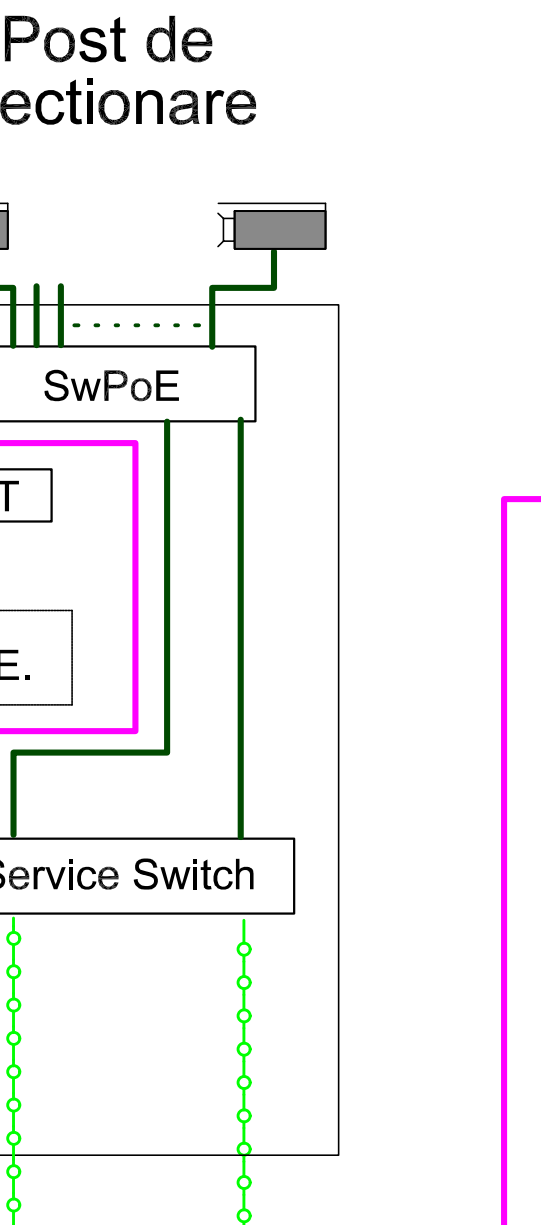
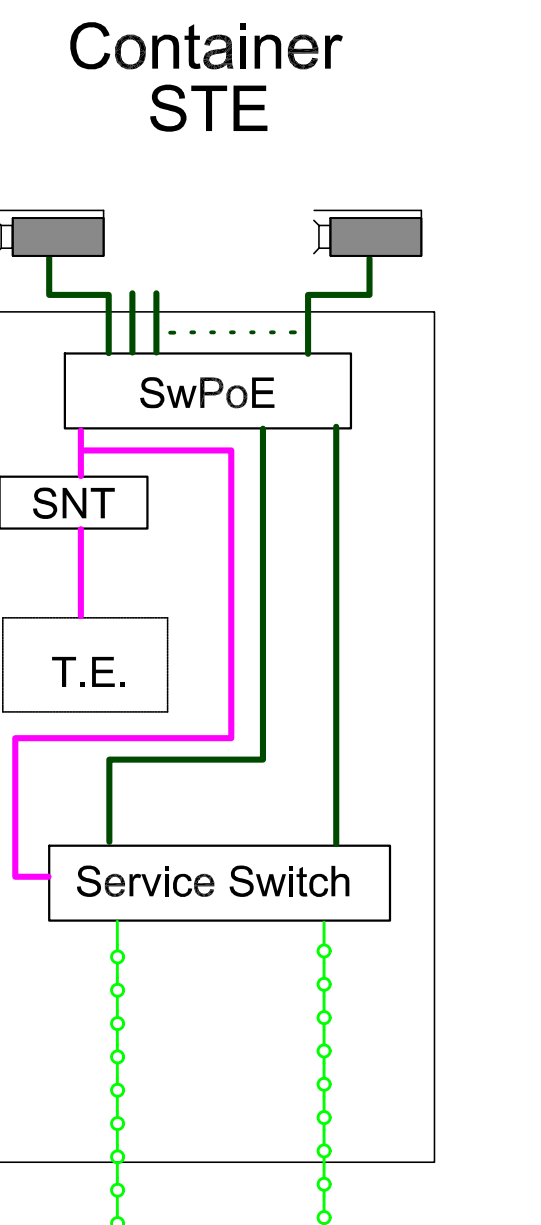
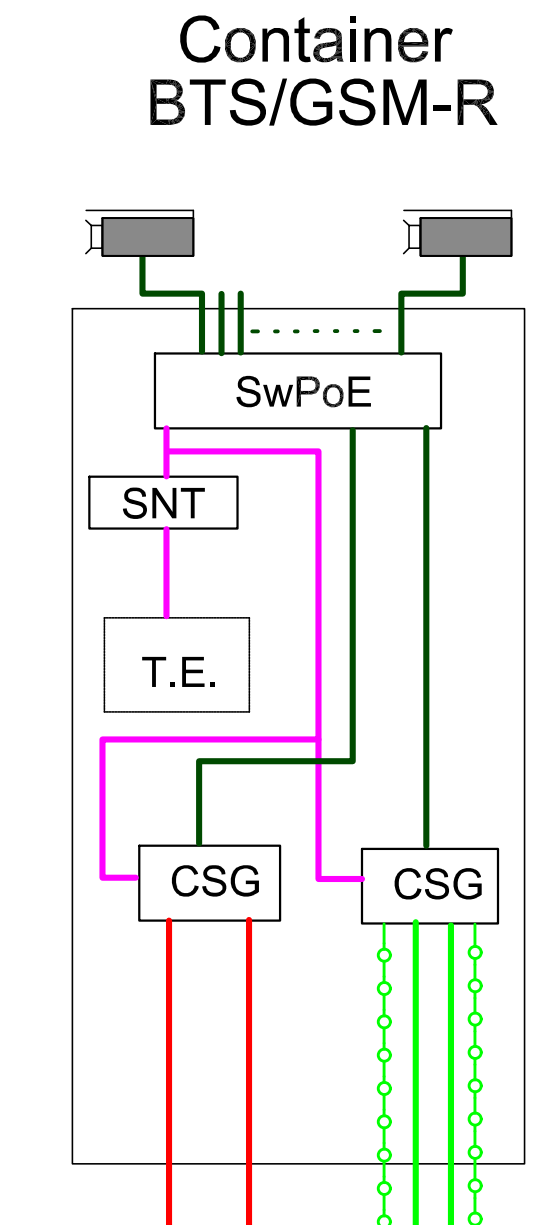
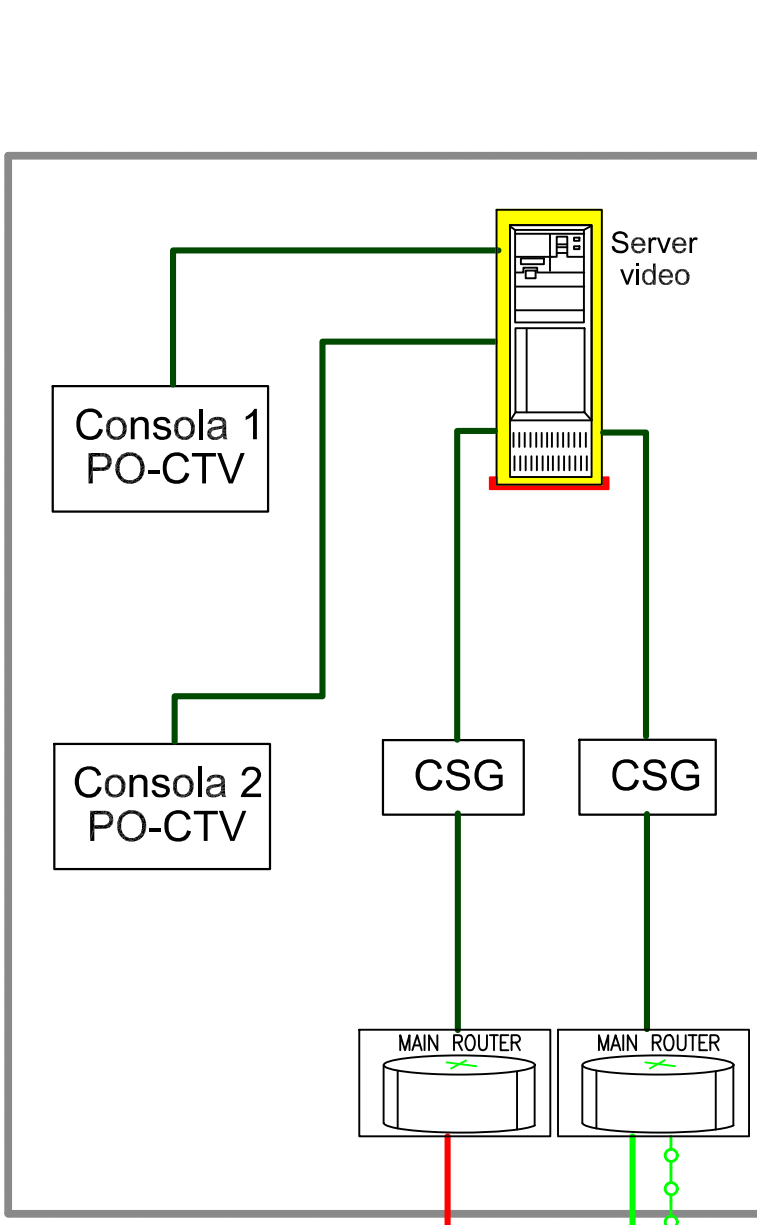
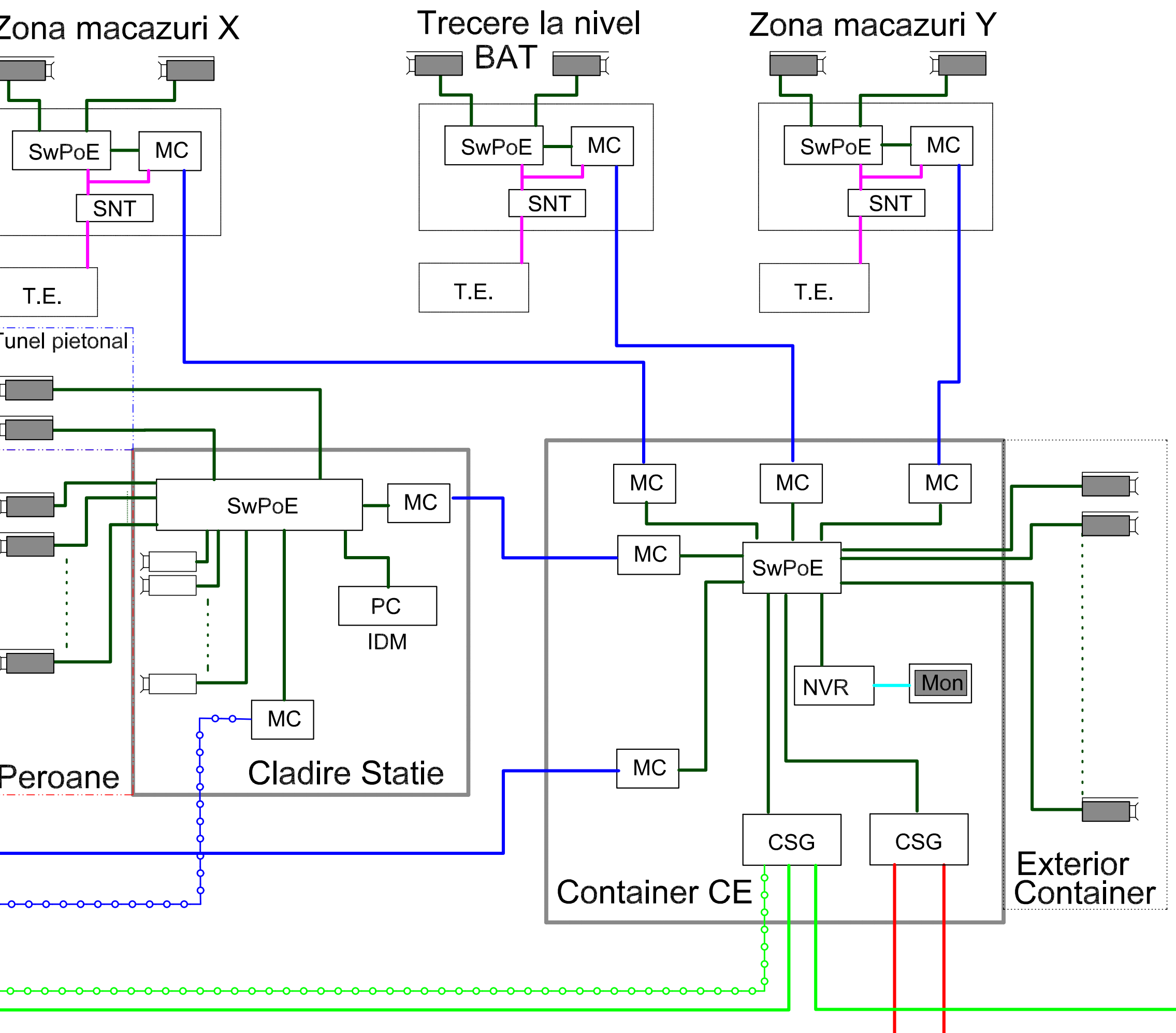

LEGENDA

- Inelul verde de fibre optice al Retei de transport
 - Inelul rosu de fibre optice al Retei de transport
 - - - FO secundara in cablu 1FO, pentru supraveghere video
 - - - FO in cablu FO-TTR magistral de 24 fibre, pentru SAP
 - Cablu FO local
 - Cablu F2TP
 - Cablu semnal video
 - Cablu pentru alimentarea cu energie electrica
- NVR Unitate de inregistrare a imaginilor video
 - MC Convertor mediu digital-optic
 - SwPoE Switch cu porturi inclusiv PoE
 - CSG CSG - Cell Site gateway
 - Consola .. PO-CTV Consola post de operare CTV
 - SNT Sursa de tensiune neintreruptibila (UPS+Acumulatori)
 - T.E. Sursa de alimentare 230 V c.a.
 - Mon Monitor
 - [Camera] Camera video de interior
 - [Camera] Camera video de exterior

NOTA
Configuratia inelurilor de fibre optice a Retei de transport este prezentata in desenul nr. E218.0.SF.00.DX.SE.4.01.001

CLIENT / CLIENT C.N.C.F. "C.F.R." - S.A.

CONSULTANT / CONSULTANT				
Faza / Phase	Postiia / Position	Nume / Name	Data / Date	Semnatura / Signature
Aprobat / Approved	Manager de Proiect / Project Manager	Sergio MENICHINI	09.2020	
Verificat / Checked	Expert Cheie / Key Expert	Pino AMODIO	09.2020	
Intocmit / Elaborated	Proiectant / Designer	Dan ANDREI	09.2020	

SUBCONSULTANT / SUBCONSULTANT				
Aprobat / Approved	Responsabil Subconsultant / Subconsultant Responsible	Intocmit / Elaborated	Proiectant / Designer	

Studiu de Fezabilitate pentru Reabilitarea liniei feroviare Craiova - Drobeta Turnu Severin - Caransebes, parte a Coridorului Orient/Est Mediteranean - Feasibility Study For The Rehabilitation Of The Railway Line Craiova - Caransebes

Project/Project 74 / 2018
Faza/Phase S.F.

SCHEMA BLOC A SISTEMULUI DE SUPRAVEGHERE VIDEO

Codificare / Codification System

E	2	1	8	0	S	F	0	0	D	X	T	C	4	0	0	1	1
---	---	---	---	---	---	---	---	---	---	---	---	---	---	---	---	---	---

Istoricul reviziilor / Revision History		
Rev.	Data/Date	Descriere Modificare / Modification description
1	09.2020	Conform solicitărilor Beneficiarului din act nr.11/2/504/2020
2		
3		
4		

Responsabilitatea privind această publicație revine integral autorului. Uniunea Europeană nu este responsabilă pentru modul în care sunt utilizate informațiile publicate.
The contents of this publication are the sole responsibility of (name of the implementing partner) and do not necessarily reflect the opinion of the European Union.