

MATERIALE

1. Beton cf. CP 012/2007

Element constructiv	Beton	Clasa de expunere	Tasare	A/C	Ciment	Armatura
Beton egalizare	C8/10	-	-	-	-	-
Pereu	C30/37	XC4;XF2	S4	0.500	300	-
Piloti	C25/30	XC2	S4	0.60	375	B500SC/BST500SC
Radier	C25/30	XC2;XF2	S4	0.60	260	B500SC/BST500SC
Elevatii	C30/37	XC4;XF2;XD1	S3	0.55	300	B500SC/BST500SC
	C35/45	XC4;XF2;XD3	S3	0.50	320	B500SC/BST500SC
Placi racordare / Grinda rezemare	C25/30	XC2;XF2	S4	0.60	300	B500SC/BST500SC
Grinda prefabricata post-tensionata	C45/55	XC4;XD1;XF2	S4	0.40	320	B500SC/BST500SC
Grinda prefabricata pretensionata	C50/60	XC4;XD1;XF2	S4	0.40	320	B500SC/BST500SC
Placa suprabetonare / Borduri	C35/45	XC4;XF4;XD3	S3	0.50	340	B500SC/BST500SC
Predale prefabricate	C35/45	XC4;XD1;XF4	S4	0.50	340	B500SC/BST500SC
Prefabricat grinda parapet	C35/45	XC4;XD3;XF4	S4	0.45	340	B500SC/BST500SC

2. Otel

Armatura moale	B500SC/BST500SC
Armatura pretensionata	TBP Y1860S7
Otel tablier metalic	S355NL / S355J2+N, echivalent OL52EP

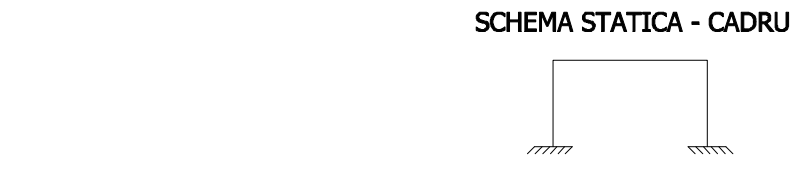
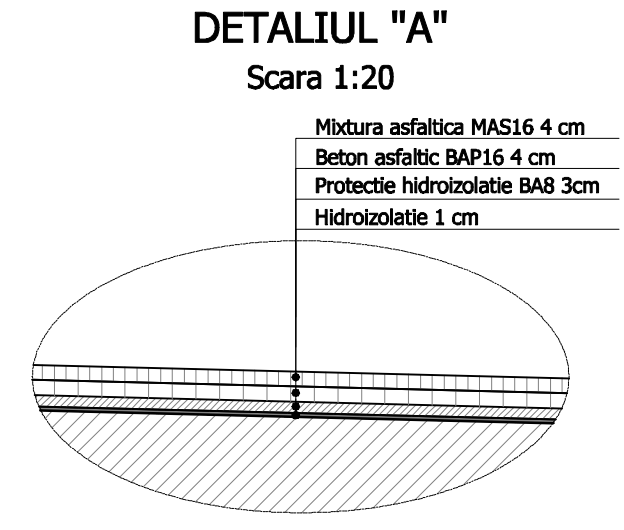

Convol de calcul: LM1, LM2, conf. SR EN 1991-2/2005
 Categoria de importanta: "B"
 Exigente de verificare: A4, B2, D
 Parametri seismici: $a_g=0.25g$, $T_c=0.70s$ conf. cod P100/1-2013, SR EN 1998-2/2006

PROIECT CO-FINANTAT DE UNIUNEA EUROPEANA PRIN PROGRAMUL OPERATIONAL INFRASTRUCTURA MARE

UNIUNEA EUROPEANA

GUVERNUL ROMANIEI

INSTRUMENTUL STRATEGIC 2014-2020 POIM

AMPLASAMENT

BENEFICIAR

MINISTERUL TRANSPORTURILOR SI INFRASTRUCTURII

COMPANIA NATIONALA DE ADMINISTRARE A INFRASTRUCTURII RUTIERE

CNAIR

PROIECTANT GENERAL

acciona

SUBPROIECTANT

INVESTITIA

COMPLETAREA STUDIULUI DE FEZABILITATE PENTRU AUTOSTRADA TARGU MURES-TARGU NEAMT

FAZA DE PROIECTARE

Studiu de Fezabilitate

Coordonator de proiect ing. CHIOTAN Vlad	Proiectat ing. ZAINESCU Alina
	Verificat ing. PREDESCU Mihai

Proiect nr: 92/36788 / 28.05.2019

Scara: 1:500 / 1:200 / 1:20

Data: Februarie 2022

Pod pe autostrada peste vale km 80+231
DISPOZITIE GENERALA

Cod: MN-T2-S3-STR-ST47-DG-047 Rev. 04