

| TRASARE RADIER CULEE "C1"-fir stg | | | |
|-----------------------------------|-----------|-----------|------|
| Pct. | X-(EST) | Y-(NORD) | Z |
| S24-C1S-R01 | 241581.73 | 590985.65 | 91.7 |
| S24-C1S-R02 | 241573.50 | 590983.53 | 91.7 |
| S24-C1S-R03 | 241570.59 | 590994.81 | 91.7 |
| S24-C1S-R04 | 241578.82 | 590996.93 | 91.7 |

| TRASARE PILOTI CULEE "C1"-fir stg | | | | |
|-----------------------------------|-----------|-----------|------|------|
| Pct. | X-(EST) | Y-(NORD) | Zsup | Zinf |
| S24-C1S-P01 | 241571.93 | 590994.02 | 91.8 | 71.7 |
| S24-C1S-P02 | 241574.98 | 590994.80 | 91.8 | 71.7 |
| S24-C1S-P03 | 241578.03 | 590995.59 | 91.8 | 71.7 |
| S24-C1S-P04 | 241572.71 | 590990.97 | 91.8 | 71.7 |
| S24-C1S-P05 | 241575.76 | 590991.75 | 91.8 | 71.7 |
| S24-C1S-P06 | 241578.81 | 590992.54 | 91.8 | 71.7 |
| S24-C1S-P07 | 241573.50 | 590987.92 | 91.8 | 71.7 |
| S24-C1S-P08 | 241576.55 | 590988.70 | 91.8 | 71.7 |
| S24-C1S-P09 | 241579.60 | 590989.49 | 91.8 | 71.7 |
| S24-C1S-P10 | 241574.29 | 590984.86 | 91.8 | 71.7 |
| S24-C1S-P11 | 241577.34 | 590985.65 | 91.8 | 71.7 |
| S24-C1S-P12 | 241580.39 | 590986.44 | 91.8 | 71.7 |

Oradea

| TRASARE RADIER CULEE "C1"-fir dr | | | |
|----------------------------------|-----------|-----------|-------|
| Pct. | X-(EST) | Y-(NORD) | Z |
| S24-C1D-R01 | 241577.98 | 591000.17 | 91.70 |
| S24-C1D-R02 | 241569.75 | 590998.05 | 91.70 |
| S24-C1D-R03 | 241566.84 | 591009.33 | 91.70 |
| S24-C1D-R04 | 241575.07 | 591011.45 | 91.70 |

| TRASARE PILOTI CULEE "C1"-fir dr | | | | |
|----------------------------------|-----------|-----------|-------|-------|
| Pct. | X-(EST) | Y-(NORD) | Zsup | Zinf |
| S24-C1D-P01 | 241568.18 | 591008.54 | 91.80 | 71.70 |
| S24-C1D-P02 | 241571.23 | 591009.33 | 91.80 | 71.70 |
| S24-C1D-P03 | 241574.28 | 591010.11 | 91.80 | 71.70 |
| S24-C1D-P04 | 241568.97 | 591005.49 | 91.80 | 71.70 |
| S24-C1D-P05 | 241572.02 | 591006.28 | 91.80 | 71.70 |
| S24-C1D-P06 | 241575.07 | 591007.06 | 91.80 | 71.70 |
| S24-C1D-P07 | 241569.76 | 591002.44 | 91.80 | 71.70 |
| S24-C1D-P08 | 241572.81 | 591003.23 | 91.80 | 71.70 |
| S24-C1D-P09 | 241575.86 | 591004.01 | 91.80 | 71.70 |
| S24-C1D-P10 | 241570.54 | 590999.39 | 91.80 | 71.70 |
| S24-C1D-P11 | 241573.59 | 591000.18 | 91.80 | 71.70 |
| S24-C1D-P12 | 241576.64 | 591000.96 | 91.80 | 71.70 |

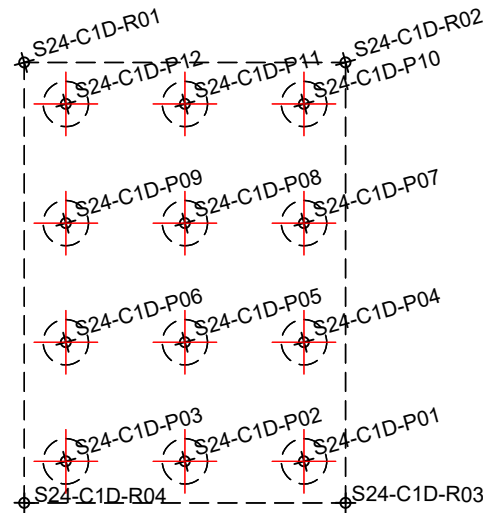
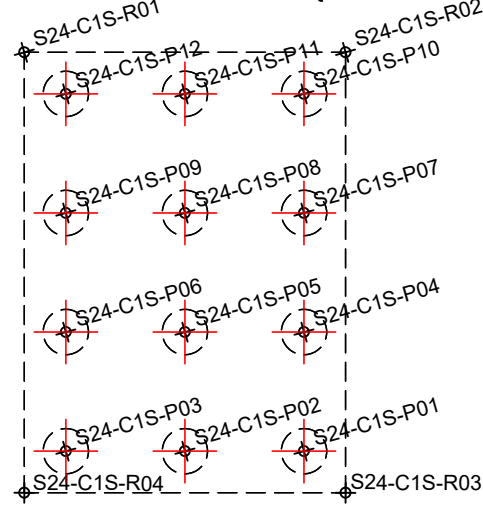
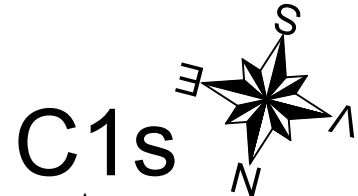

C1d

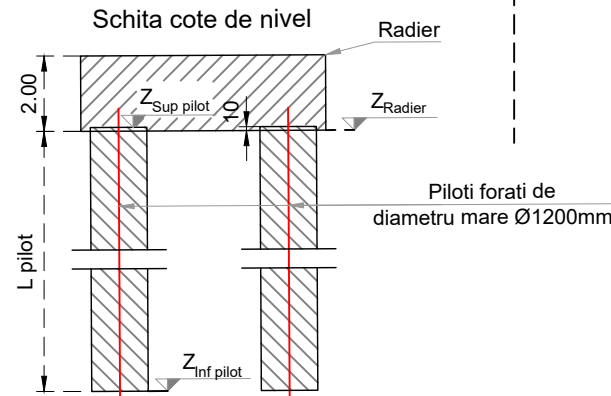

| TRASARE RADIER PILA "P1"- fir stanga | | | |
|--------------------------------------|-----------|-----------|-------|
| Pct. | Y-(EST) | X-(NORD) | Z |
| S24-P1S-R01 | 241540.67 | 590975.06 | 91.84 |
| S24-P1S-R02 | 241538.54 | 590974.51 | 91.84 |
| S24-P1S-R03 | 241535.63 | 590985.79 | 91.84 |
| S24-P1S-R04 | 241537.76 | 590986.34 | 91.84 |

| TRASARE PILOTI PILA "P1"- fir stanga | | | | |
|--------------------------------------|-----------|-----------|-------|-------|
| Pct. | Y-(EST) | X-(NORD) | Zsup | Zinf |
| S24-P1S-P01 | 241536.97 | 590985.00 | 91.94 | 71.84 |
| S24-P1S-P02 | 241537.76 | 590981.95 | 91.94 | 71.84 |
| S24-P1S-P03 | 241538.54 | 590978.90 | 91.94 | 71.84 |
| S24-P1S-P04 | 241539.33 | 590975.85 | 91.94 | 71.84 |

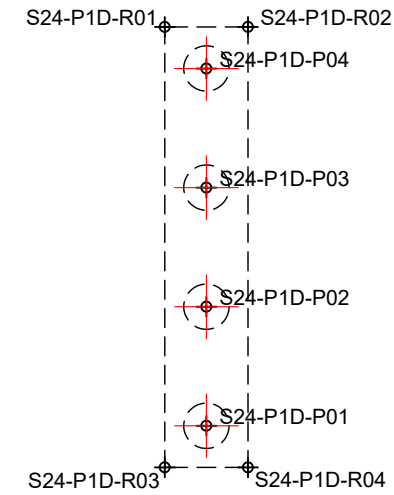
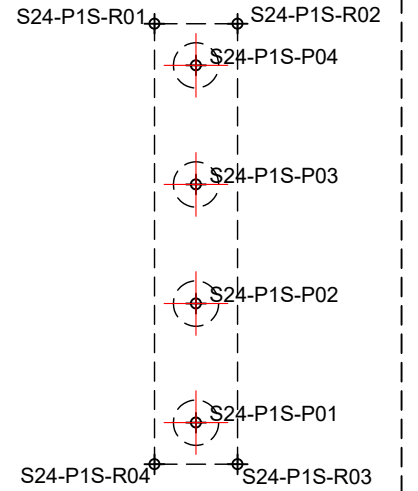

P1d

| TRASARE RADIER PILA "P1"- fir dreapta | | | |
|---------------------------------------|-----------|-----------|-------|
| Pct. | Y-(EST) | X-(NORD) | Z |
| S24-P1D-R01 | 241553.39 | 590993.83 | 91.51 |
| S24-P1D-R02 | 241551.26 | 590993.28 | 91.51 |
| S24-P1D-R03 | 241550.48 | 591005.11 | 91.51 |
| S24-P1D-R04 | 241548.35 | 591004.56 | 91.51 |

| TRASARE PILOTI PILA "P1"- fir dreapta | | | | |
|---------------------------------------|-----------|-----------|-------|-------|
| Pct. | Y-(EST) | X-(NORD) | Zsup | Zinf |
| S24-P1D-P01 | 241549.69 | 591003.77 | 91.61 | 71.51 |
| S24-P1D-P02 | 241550.47 | 591000.72 | 91.61 | 71.51 |
| S24-P1D-P03 | 241551.26 | 590997.67 | 91.61 | 71.51 |
| S24-P1D-P04 | 241552.05 | 590994.62 | 91.61 | 71.51 |

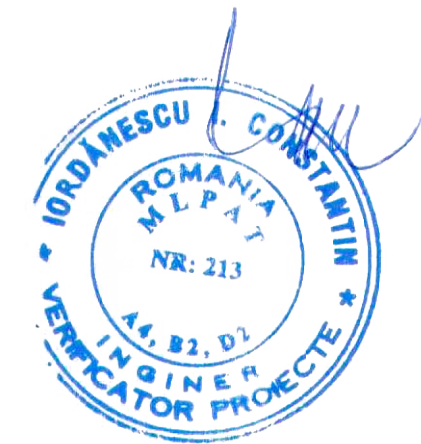

PROIECTANT / DESIGNER:
S.C. CONSITRANS S.R.L.



BENEFICIAR / BENEFICIARY:
MUNICIPIUL ARAD, MUNICIPIUL ORADEA, CONSILIUL JUDETEAN ARAD, CONSILIUL JUDETEAN BIHOR CNAIR

FUNCTIA / POSITION:

NUME / NAME:

SEMNTATURA / SIGNATURE:

Titlu plansa / Drawing title:
Plan trasare - plan 1/11
Layout plan - plan 1/11

REV/REV.:

DATA/DATE:

DETALII REVIZIE / REVISION DETAILS:
P.T.E.

PROIECTAT / DESIGNER:
Consitrans

INVESTITIA / INVESTMENT:
ACTUALIZARE/COMPLETARE/REVIZUIRE (S.F. + P.A.C. + P.O.E + P.T.E.) "DRUM EXPRES ARAD ORADEA"
ACTUALIZATION/COMPLETION (S.F. + P.A.C. + P.O.E + P.T.E.) "EXPRESS ROAD ARAD ORADEA"

COORDONATOR DE PROIECT / PROJECT MANAGER
ing. S. VEACESLAV

SEF PROIECT SPECIALITATE / TEAM LEADER
ing. D. COVELTIR

ing. V. URDAREANU

Pod pe DX la km 41+055 peste DN79 si CF
Bridge on DX at km 41+055 over DN79 and CF

REV/REV.:

DATA/DATE:

DETALII REVIZIE / REVISION DETAILS:

PROIECTAT / DESIGNER:

FAZA PROIECTARE / DESIGN STAGE:
PROIECT TEHNIC DE EXECUTIE / EXECUTION TECHNICAL PROJECT

PROIECTAT / DESIGNER:

ing. D. COVELTIR

VERIFICATOR / INTERNAL CHECKER:

Cod plansa / Drawing code:
CST-0121-PTE-02-DX- 02-P24-PTR-01-R00

REV/REV.:

DATA/DATE:

DETALII REVIZIE / REVISION DETAILS:

PROIECTAT / DESIGNER:



PROIECT CO-FINANAT DIN FONDUL DE COEZIUNE, PRIN PROGRAMUL OPERATIONAL INFRASTRUCTURA MARE / PROJECT CO-FINANCED FROM THE COHESION FUND, THROUGH THE LARGE INFRASTRUCTURE OPERATIONAL PROGRAM

Contract /Contract: 14724/01.07.2021
Data /Date: 11.2023
Scara /Scale: 1:200

VERIFICATOR / INTERNAL CHECKER:

ing. D. COVELTIR

VERIFICATOR / INTERNAL CHECKER:

Cod plansa / Drawing code:
CST-0121-PTE-02-DX- 02-P24-PTR-01-R00

REV/REV.:

DATA/DATE:

DETALII REVIZIE / REVISION DETAILS:

PROIECTAT / DESIGNER:

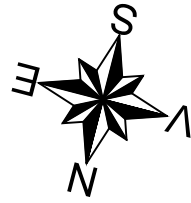

P2s

| TRASARE RADIER PILA "P2"- fir stanga | | | |
|--------------------------------------|-----------|-----------|-------|
| Pct. | Y-(EST) | X-(NORD) | Z |
| S24-P2S-R01 | 241500.49 | 590964.70 | 92.08 |
| S24-P2S-R02 | 241498.36 | 590964.15 | 92.08 |
| S24-P2S-R03 | 241495.45 | 590975.43 | 92.08 |
| S24-P2S-R04 | 241497.58 | 590975.98 | 92.08 |

| TRASARE PILOTI PILA "P2"- fir stanga | | | | |
|--------------------------------------|-----------|-----------|-------|-------|
| Pct. | Y-(EST) | X-(NORD) | Zsup | Zinf |
| S24-P2S-P01 | 241496.79 | 590974.64 | 92.18 | 72.08 |
| S24-P2S-P02 | 241497.57 | 590971.59 | 92.18 | 72.08 |
| S24-P2S-P03 | 241498.36 | 590968.54 | 92.18 | 72.08 |
| S24-P2S-P04 | 241499.15 | 590965.49 | 92.18 | 72.08 |

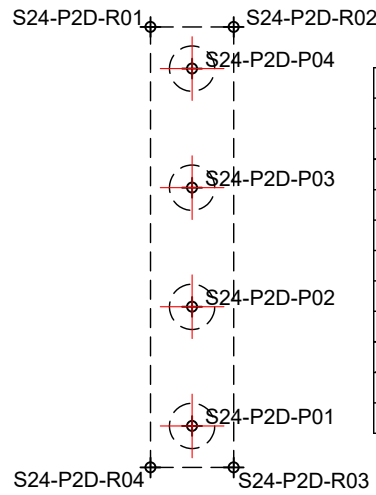
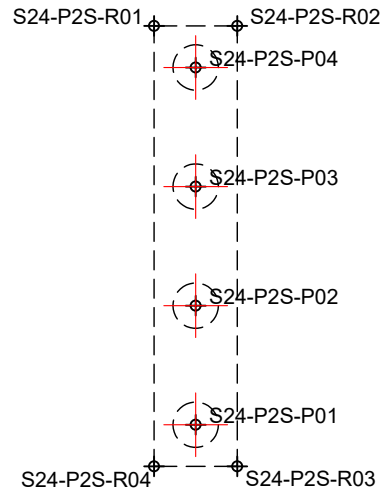

| TRASARE RADIER PILA "P2"- fir dreapta | | | |
|---------------------------------------|-----------|-----------|-------|
| Pct. | Y-(EST) | X-(NORD) | Z |
| S24-P2D-R01 | 241513.20 | 590983.47 | 91.79 |
| S24-P2D-R02 | 241511.07 | 590982.92 | 91.79 |
| S24-P2D-R03 | 241508.16 | 590994.20 | 91.79 |
| S24-P2D-R04 | 241510.29 | 590994.75 | 91.79 |

| TRASARE PILOTI PILA "P2"- fir dreapta | | | | |
|---------------------------------------|-----------|-----------|-------|-------|
| Pct. | Y-(EST) | X-(NORD) | Zsup | Zinf |
| S24-P2D-P01 | 241509.50 | 590993.41 | 91.89 | 71.79 |
| S24-P2D-P02 | 241510.29 | 590990.36 | 91.89 | 71.79 |
| S24-P2D-P03 | 241511.07 | 590987.31 | 91.89 | 71.79 |
| S24-P2D-P04 | 241511.86 | 590984.26 | 91.89 | 71.79 |

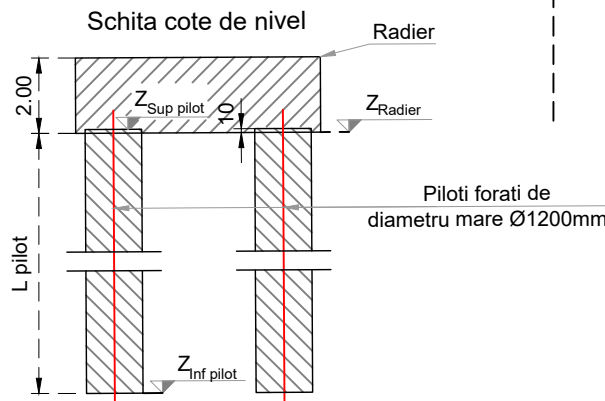

| TRASARE RADIER PILA "P3"- fir stanga | | | |
|--------------------------------------|-----------|-----------|-------|
| Pct. | Y-(EST) | X-(NORD) | Z |
| S24-P3S-R01 | 241472.88 | 590957.60 | 91.84 |
| S24-P3S-R02 | 241467.85 | 590956.31 | 91.84 |
| S24-P3S-R03 | 241464.95 | 590967.54 | 91.84 |
| S24-P3S-R04 | 241469.99 | 590968.84 | 91.84 |

| TRASARE PILOTI PILA "P3"- fir stanga | | | | |
|--------------------------------------|-----------|-----------|-------|-------|
| Pct. | Y-(EST) | X-(NORD) | Zsup | Zinf |
| S24-P3S-P01 | 241466.28 | 590966.77 | 91.94 | 71.84 |
| S24-P3S-P02 | 241469.19 | 590967.52 | 91.94 | 71.84 |
| S24-P3S-P03 | 241467.07 | 590963.72 | 91.94 | 71.84 |
| S24-P3S-P04 | 241469.98 | 590964.47 | 91.94 | 71.84 |
| S24-P3S-P05 | 241467.86 | 590960.67 | 91.94 | 71.84 |
| S24-P3S-P06 | 241470.76 | 590961.42 | 91.94 | 71.84 |
| S24-P3S-P07 | 241468.64 | 590957.62 | 91.94 | 71.84 |
| S24-P3S-P08 | 241471.55 | 590958.37 | 91.94 | 71.84 |

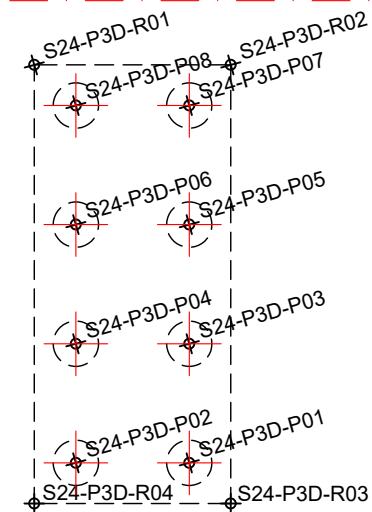
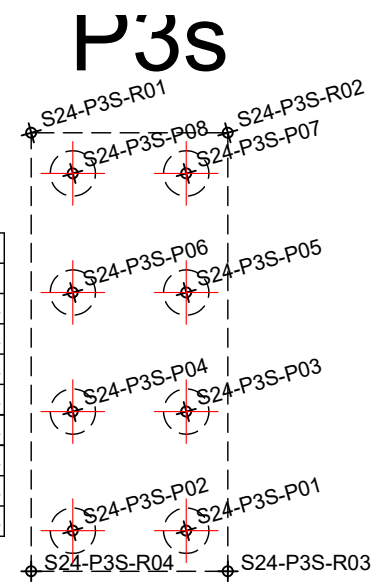

| TRASARE RADIER PILA "P3"- fir dreapta | | | |
|---------------------------------------|-----------|-----------|-------|
| Pct. | Y-(EST) | X-(NORD) | Z |
| S24-P3D-R01 | 241478.82 | 590974.63 | 91.69 |
| S24-P3D-R02 | 241473.78 | 590973.33 | 91.69 |
| S24-P3D-R03 | 241470.89 | 590984.56 | 91.69 |
| S24-P3D-R04 | 241475.92 | 590985.86 | 91.69 |

| TRASARE PILOTI PILA "P3"- fir dreapta | | | | |
|---------------------------------------|-----------|-----------|-------|-------|
| Pct. | Y-(EST) | X-(NORD) | Zsup | Zinf |
| S24-P3D-P01 | 241472.22 | 590983.79 | 91.79 | 71.69 |
| S24-P3D-P02 | 241475.13 | 590984.54 | 91.79 | 71.69 |
| S24-P3D-P03 | 241473.01 | 590980.74 | 91.79 | 71.69 |
| S24-P3D-P04 | 241475.91 | 590981.49 | 91.79 | 71.69 |
| S24-P3D-P05 | 241473.79 | 590977.69 | 91.79 | 71.69 |
| S24-P3D-P06 | 241476.70 | 590978.44 | 91.79 | 71.69 |
| S24-P3D-P07 | 241474.58 | 590974.64 | 91.79 | 71.69 |
| S24-P3D-P08 | 241477.49 | 590975.39 | 91.79 | 71.69 |

P3d



| | | | | | | | | | |
|--|---|--|--|--|---|--|--|--|--|
| PROIECTANT / DESIGNER: S.C. CONSITRANS S.R.L. | BENEFICIAR / BENEFICIARY: MUNICIPIUL ARAD, MUNICIPIUL ORADEA, CONSILIUL JUDETEAN ARAD, CONSILIUL JUDETEAN BIHOR CNAIR | FUNCTIA / POSITION: COORDONATOR DE PROIECT / PROJECT MANAGER | NUME / NAME: ing. S. VEACESLAV | SEMNETURA / SIGNATURE: | Titlu plansa / Drawing title: Plan trasare - plan 2/11 Layout plan - plan 2/11 | REV. / REV.: R00 | DATA / DATE: 11.2023 | DETALII REVIZIE / REVISION DETAILS: P.T.E. | PROIECTAT / DESIGNER: Consitrans |
| | | | | | | INVESTITIA / INVESTMENT: ACTUALIZARE/COMPLETARE/REVIZUIRE (S.F. + P.A.C. + P.O.E + P.T.E.) "DRUM EXPRES ARAD ORADEA" ACTUALIZATION/COMPLETION (S.F. + P.A.C. + P.O.E + P.T.E.) "EXPRESS ROAD ARAD ORADEA" | SEF PROIECT SPECIALITATE / TEAM LEADER: ing. D. COVELTIR | PROIECTAT / DESIGNER: ing. V. URDAREANU | Cod plansa / Drawing code: CST-0121-PTE-02-DX- 02-P24-PTR-02-R00 |
| FAZA PROIECTARE / DESIGN STAGE: PROIECT TEHNIC DE EXECUTIE / EXECUTION TECHNICAL PROJECT | Contract /Contract: 14724/01.07.2021 Project /Project no.: 001/2021 | Data / Date: 11.2023 | Scara /Scale: 1:200 | VERIFICAT / INTERNAL CHECKER: ing. D. COVELTIR | | | | | |

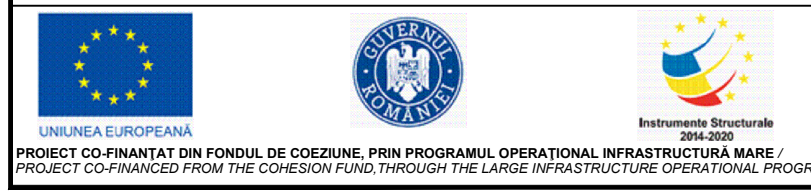

P4s

| TRASARE RADIER PILA "P4"- fir stanga | | | |
|--------------------------------------|-----------|-----------|-------|
| Pct. | Y-(EST) | X-(NORD) | Z |
| S24-P4S-R01 | 241431.73 | 590946.97 | 91.67 |
| S24-P4S-R02 | 241429.60 | 590946.42 | 91.67 |
| S24-P4S-R03 | 241426.70 | 590957.70 | 91.67 |
| S24-P4S-R04 | 241428.83 | 590958.25 | 91.67 |

| TRASARE PILOTI PILA "P4"- fir stanga | | | | |
|--------------------------------------|-----------|-----------|-------|-------|
| Pct. | Y-(EST) | X-(NORD) | Zsup | Zinf |
| S24-P4S-P01 | 241428.04 | 590956.91 | 91.77 | 71.67 |
| S24-P4S-P02 | 241428.82 | 590953.86 | 91.77 | 71.67 |
| S24-P4S-P03 | 241429.61 | 590950.81 | 91.77 | 71.67 |
| S24-P4S-P04 | 241430.40 | 590947.76 | 91.77 | 71.67 |

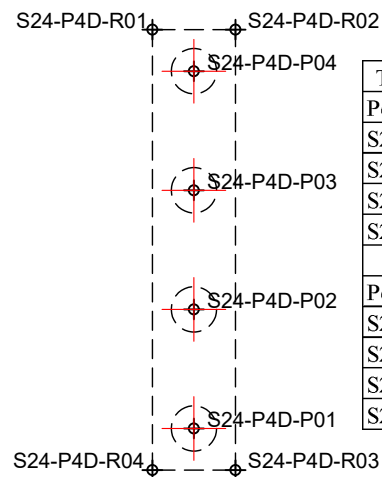
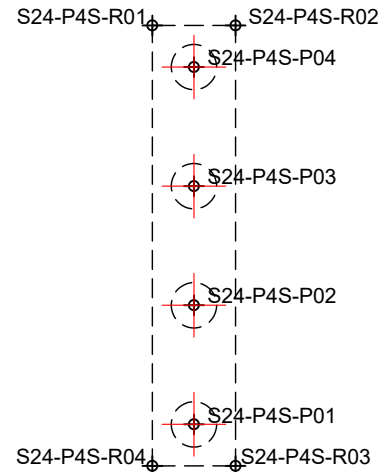

| TRASARE RADIER PILA "P4"- fir dreapta | | | |
|---------------------------------------|-----------|-----------|-------|
| Pct. | Y-(EST) | X-(NORD) | Z |
| S24-P4D-R01 | 241437.67 | 590963.99 | 91.53 |
| S24-P4D-R02 | 241435.54 | 590963.44 | 91.53 |
| S24-P4D-R03 | 241432.63 | 590974.72 | 91.53 |
| S24-P4D-R04 | 241434.76 | 590975.27 | 91.53 |

| TRASARE PILOTI PILA "P4"- fir dreapta | | | | |
|---------------------------------------|-----------|-----------|-------|-------|
| Pct. | Y-(EST) | X-(NORD) | Zsup | Zinf |
| S24-P4D-P01 | 241433.97 | 590973.93 | 91.63 | 71.53 |
| S24-P4D-P02 | 241434.76 | 590970.88 | 91.63 | 71.53 |
| S24-P4D-P03 | 241435.55 | 590967.83 | 91.63 | 71.53 |
| S24-P4D-P04 | 241436.33 | 590964.78 | 91.63 | 71.53 |

P4d

P5s

| TRASARE RADIER PILA "P5"- fir stanga | | | |
|--------------------------------------|-----------|-----------|-------|
| Pct. | Y-(EST) | X-(NORD) | Z |
| S24-P5S-R01 | 241391.55 | 590936.60 | 91.70 |
| S24-P5S-R02 | 241389.42 | 590936.05 | 91.70 |
| S24-P5S-R03 | 241386.51 | 590947.34 | 91.70 |
| S24-P5S-R04 | 241388.64 | 590947.88 | 91.70 |

| TRASARE PILOTI PILA "P5"- fir stanga | | | | |
|--------------------------------------|-----------|-----------|-------|-------|
| Pct. | Y-(EST) | X-(NORD) | Zsup | Zinf |
| S24-P5S-P01 | 241387.85 | 590946.54 | 91.80 | 71.70 |
| S24-P5S-P02 | 241388.64 | 590943.49 | 91.80 | 71.70 |
| S24-P5S-P03 | 241389.42 | 590940.44 | 91.80 | 71.70 |
| S24-P5S-P04 | 241390.21 | 590937.39 | 91.80 | 71.70 |

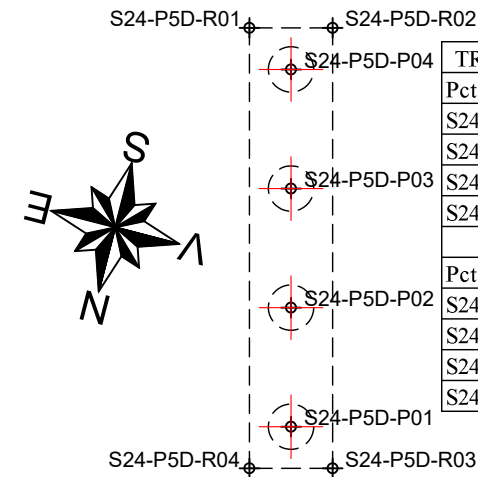
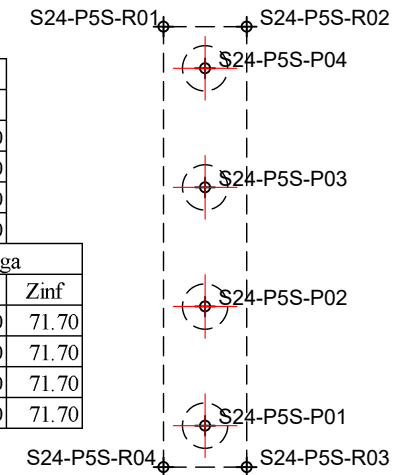

| TRASARE RADIER PILA "P5"- fir dreapta | | | |
|---------------------------------------|-----------|-----------|-------|
| Pct. | Y-(EST) | X-(NORD) | Z |
| S24-P5D-R01 | 241397.49 | 590953.63 | 91.58 |
| S24-P5D-R02 | 241395.36 | 590953.08 | 91.58 |
| S24-P5D-R03 | 241392.45 | 590964.36 | 91.58 |
| S24-P5D-R04 | 241394.58 | 590964.91 | 91.58 |

| TRASARE PILOTI PILA "P5"- fir dreapta | | | | |
|---------------------------------------|-----------|-----------|-------|-------|
| Pct. | Y-(EST) | X-(NORD) | Zsup | Zinf |
| S24-P5D-P01 | 241393.79 | 590963.57 | 91.68 | 71.58 |
| S24-P5D-P02 | 241394.57 | 590960.52 | 91.68 | 71.58 |
| S24-P5D-P03 | 241395.36 | 590957.47 | 91.68 | 71.58 |
| S24-P5D-P04 | 241396.15 | 590954.42 | 91.68 | 71.58 |

P5d

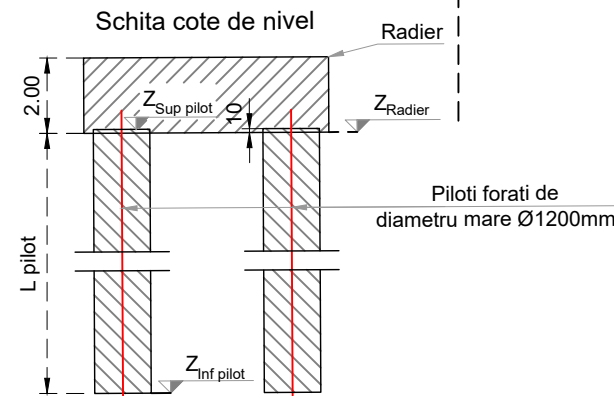

| | | | | | | | | | |
|--|---|--|--|---|---|--|--|--|--|
| PROIECTANT / DESIGNER: S.C. CONSITRANS S.R.L. | BENEFICIAR / BENEFICIARY: MUNICIPIUL ARAD, MUNICIPIUL ORADEA, CONSILIUL JUDETEAN ARAD, CONSILIUL JUDETEAN BIHOR CNAIR | FUNCTIA / POSITION: COORDONATOR DE PROIECT / PROJECT MANAGER | NUME / NAME: ing. S. VEACESLAV | SEMNTATURA / SIGNATURE: | Titlu plansa / Drawing title: Plan trasare - plan 3/11 Layout plan - plan 3/11 | REV. / REV.: R00 | DATA / DATE: 11.2023 | DETALII REVIZIE / REVISION DETAILS: P.T.E. | PROIECTAT / DESIGNER: Consitrans |
| | | | | | | INVESTITIA / INVESTMENT: ACTUALIZARE/COMPLETARE/REVIZUIRE (S.F. + P.A.C. + P.O.E + P.T.E.) "DRUM EXPRES ARAD ORADEA" ACTUALIZATION/COMPLETION (S.F. + P.A.C. + P.O.E + P.T.E.) "EXPRESS ROAD ARAD ORADEA" | SEF PROIECT SPECIALITATE / TEAM LEADER: ing. D. COVELTIR | SEMNTATURA / SIGNATURE: | Pod pe DX la km 41+055 peste DN79 si CF Bridge on DX at km 41+055 over DN79 and CF |
| FAZA PROIECTARE / DESIGN STAGE: PROIECT TEHNIC DE EXECUTIE / EXECUTION TECHNICAL PROJECT | PROIECTAT / DESIGNER: ing. D. COVELTIR | SEMNTATURA / SIGNATURE: | Cod plansa / Drawing code: CST-0121-PTE-02-DX- 02-P24-PTR-03-R00 | Contract / Contract: 14724/01.07.2021 | Data / Date: 11.2023 | Scara / Scale: 1:200 | VERIFICAT / INTERNAL CHECKER: ing. D. COVELTIR | UNIUNEA EUROPEANA PROIECT CO-FINANAT DIN FONDUL DE COEZIUNE, PRIN PROGRAMUL OPERATIONAL INFRASTRUCTURA MARE / PROJECT CO-FINANCED FROM THE COHESION FUND, THROUGH THE LARGE INFRASTRUCTURE OPERATIONAL PROGRAM | |

| TRASARE RADIER PILA "P6"- fir stanga | | | |
|--------------------------------------|-----------|-----------|-------|
| Pct. | Y-(EST) | X-(NORD) | Z |
| S24-P6S-R01 | 241353.29 | 590926.76 | 91.43 |
| S24-P6S-R02 | 241348.26 | 590925.47 | 91.43 |
| S24-P6S-R03 | 241345.36 | 590936.70 | 91.43 |
| S24-P6S-R04 | 241350.40 | 590938.00 | 91.43 |

| TRASARE PILOTI PILA "P6"- fir stanga | | | | |
|--------------------------------------|-----------|-----------|-------|-------|
| Pct. | Y-(EST) | X-(NORD) | Zsup | Zinf |
| S24-P6S-P01 | 241346.70 | 590935.93 | 91.53 | 71.43 |
| S24-P6S-P02 | 241349.60 | 590936.68 | 91.53 | 71.43 |
| S24-P6S-P03 | 241347.48 | 590932.88 | 91.53 | 71.43 |
| S24-P6S-P04 | 241350.39 | 590933.63 | 91.53 | 71.43 |
| S24-P6S-P05 | 241348.27 | 590929.83 | 91.53 | 71.43 |
| S24-P6S-P06 | 241351.17 | 590930.58 | 91.53 | 71.43 |
| S24-P6S-P07 | 241349.06 | 590926.78 | 91.53 | 71.43 |
| S24-P6S-P08 | 241351.96 | 590927.53 | 91.53 | 71.43 |

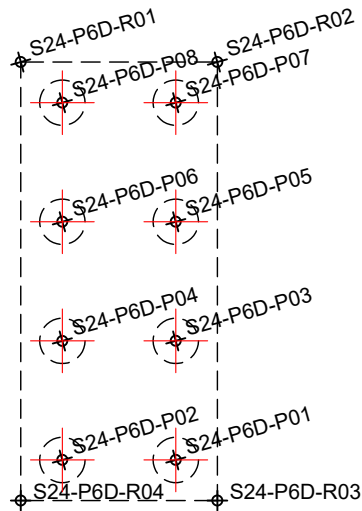
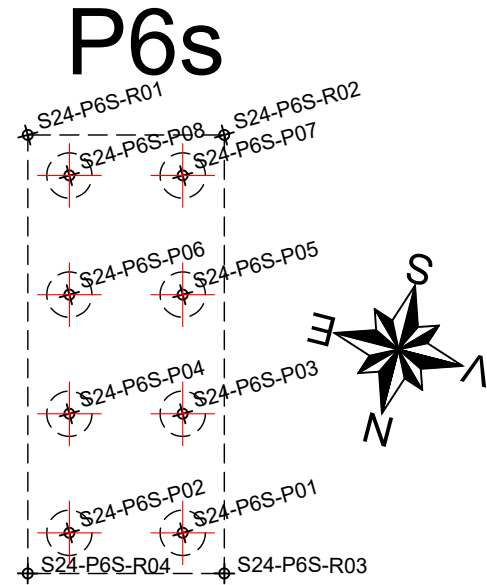

P6d

| TRASARE RADIER PILA "P6"- fir dreapta | | | |
|---------------------------------------|-----------|-----------|-------|
| Pct. | Y-(EST) | X-(NORD) | Z |
| S24-P6D-R01 | 241359.23 | 590943.79 | 91.33 |
| S24-P6D-R02 | 241354.20 | 590942.49 | 91.33 |
| S24-P6D-R03 | 241351.30 | 590953.72 | 91.33 |
| S24-P6D-R04 | 241356.34 | 590955.02 | 91.33 |

| TRASARE PILOTI PILA "P6"- fir dreapta | | | | |
|---------------------------------------|-----------|-----------|-------|-------|
| Pct. | Y-(EST) | X-(NORD) | Zsup | Zinf |
| S24-P6D-P01 | 241352.63 | 590952.95 | 91.43 | 71.33 |
| S24-P6D-P02 | 241355.54 | 590953.70 | 91.43 | 71.33 |
| S24-P6D-P03 | 241353.42 | 590949.90 | 91.43 | 71.33 |
| S24-P6D-P04 | 241356.32 | 590950.65 | 91.43 | 71.33 |
| S24-P6D-P05 | 241354.21 | 590946.85 | 91.43 | 71.33 |
| S24-P6D-P06 | 241357.11 | 590947.60 | 91.43 | 71.33 |
| S24-P6D-P07 | 241354.99 | 590943.80 | 91.43 | 71.33 |
| S24-P6D-P08 | 241357.90 | 590944.55 | 91.43 | 71.33 |

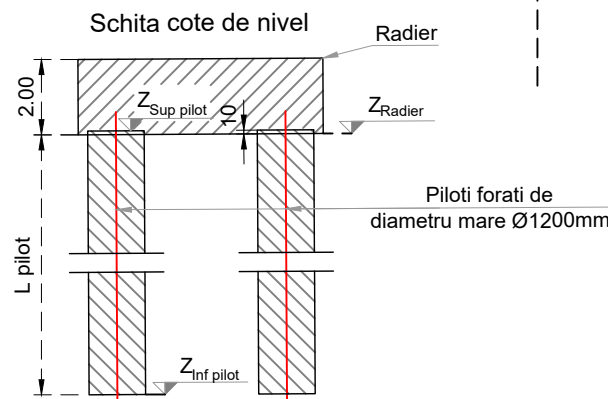

P7s

| TRASARE RADIER PILA "P7"- fir stanga | | | |
|--------------------------------------|-----------|-----------|-------|
| Pct. | Y-(EST) | X-(NORD) | Z |
| S24-P7S-R01 | 241312.15 | 590916.13 | 91.02 |
| S24-P7S-R02 | 241310.02 | 590915.58 | 91.02 |
| S24-P7S-R03 | 241307.11 | 590926.86 | 91.02 |
| S24-P7S-R04 | 241309.24 | 590927.41 | 91.02 |

| TRASARE PILOTI PILA "P7"- fir stanga | | | | |
|--------------------------------------|-----------|-----------|-------|-------|
| Pct. | Y-(EST) | X-(NORD) | Zsup | Zinf |
| S24-P7S-P01 | 241308.45 | 590926.07 | 91.12 | 71.02 |
| S24-P7S-P02 | 241309.23 | 590923.02 | 91.12 | 71.02 |
| S24-P7S-P03 | 241310.02 | 590919.97 | 91.12 | 71.02 |
| S24-P7S-P04 | 241310.81 | 590916.92 | 91.12 | 71.02 |

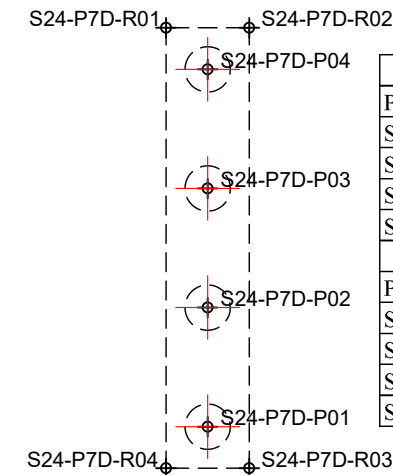
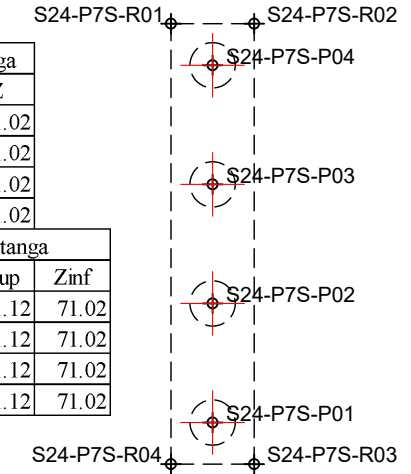

P7d

| TRASARE RADIER PILA "P7"- fir dreapta | | | |
|---------------------------------------|-----------|-----------|-------|
| Pct. | Y-(EST) | X-(NORD) | Z |
| S24-P7D-R01 | 241318.08 | 590933.15 | 90.94 |
| S24-P7D-R02 | 241315.95 | 590932.60 | 90.94 |
| S24-P7D-R03 | 241313.05 | 590943.88 | 90.94 |
| S24-P7D-R04 | 241315.18 | 590944.43 | 90.94 |

| TRASARE PILOTI PILA "P7"- fir dreapta | | | | |
|---------------------------------------|-----------|-----------|-------|-------|
| Pct. | Y-(EST) | X-(NORD) | Zsup | Zinf |
| S24-P7D-P01 | 241314.39 | 590943.09 | 91.04 | 70.94 |
| S24-P7D-P02 | 241315.17 | 590940.04 | 91.04 | 70.94 |
| S24-P7D-P03 | 241315.96 | 590936.99 | 91.04 | 70.94 |
| S24-P7D-P04 | 241316.75 | 590933.94 | 91.04 | 70.94 |



PROIECTANT / DESIGNER:
S.C. CONSITRANS S.R.L.



BENEFICIAR / BENEFICIARY:
MUNICIPIUL ARAD, MUNICIPIUL ORADEA, CONSILIUL JUDETEAN ARAD, CONSILIUL JUDETEAN BIHOR CNAIR

FUNCTIA / POSITION:
COORDONATOR DE PROIECT / PROJECT MANAGER

NUME / NAME:
ing. S. VEACESLAV

SEMNATURA / SIGNATURE:
[Signature]

Titlu plansa / Drawing title:
Plan trasare - plan 4/11
Layout plan - plan 4/11

REV/REV.:
R00

DATA/DATE:
11.2023

DETALII REVIZIE / REVISION DETAILS:
P.T.E.

PROIECTAT / DESIGNER:
Consitrans

INVESTITIA / INVESTMENT:
ACTUALIZARE/COMPLETARE/REVIZUIRE (S.F. + P.A.C. + P.O.E + P.T.E.) "DRUM EXPRES ARAD ORADEA"
ACTUALIZATION/COMPLETION (S.F. + P.A.C. + P.O.E + P.T.E.) "EXPRESS ROAD ARAD ORADEA"

SEF PROIECT SPECIALITATE / TEAM LEADER
ing. D. COVELTIR

Pod pe DX la km 41+055 peste DN79 si CF
Bridge on DX at km 41+055 over DN79 and CF

FAZA PROIECTARE / DESIGN STAGE:
PROIECT TEHNIC DE EXECUTIE / EXECUTION TECHNICAL PROJECT

PROIECTAT / DESIGNER:
ing. V. URDAREANU

LUCRARI DE POD / BRIDGE WORKS

Contract /Contract: 14724/01.07.2021
Data /Date: 11.2023
Scara /Scale: 1:200

VERIFICAT / INTERNAL CHECKER:
ing. D. COVELTIR

Cod plansa / Drawing code:
CST-0121-PTE-02-DX- 02-P24-PTR-04-R00



UNIUNEA EUROPEANA



GUVERNUL ROMANIEI



Instrumente Structurale 2014-2020

PROIECT CO-FINANAT DIN FONDUL DE COEZIUNE, PRIN PROGRAMUL OPERATIONAL INFRASTRUCTURA MARE / PROJECT CO-FINANCED FROM THE COHESION FUND, THROUGH THE LARGE INFRASTRUCTURE OPERATIONAL PROGRAM

P8s

| TRASARE RADIER PILA "P8"- fir stanga | | | |
|--------------------------------------|-----------|-----------|-------|
| Pct. | Y-(EST) | X-(NORD) | Z |
| S24-P8S-R01 | 241271.96 | 590905.76 | 90.82 |
| S24-P8S-R02 | 241269.83 | 590905.21 | 90.82 |
| S24-P8S-R03 | 241266.92 | 590916.50 | 90.82 |
| S24-P8S-R04 | 241269.05 | 590917.04 | 90.82 |

| TRASARE PILOTI PILA "P8"- fir stanga | | | | |
|--------------------------------------|-----------|-----------|-------|-------|
| Pct. | Y-(EST) | X-(NORD) | Zsup | Zinf |
| S24-P8S-P01 | 241268.26 | 590915.70 | 90.92 | 70.82 |
| S24-P8S-P02 | 241269.05 | 590912.65 | 90.92 | 70.82 |
| S24-P8S-P03 | 241269.84 | 590909.60 | 90.92 | 70.82 |
| S24-P8S-P04 | 241270.62 | 590906.55 | 90.92 | 70.82 |

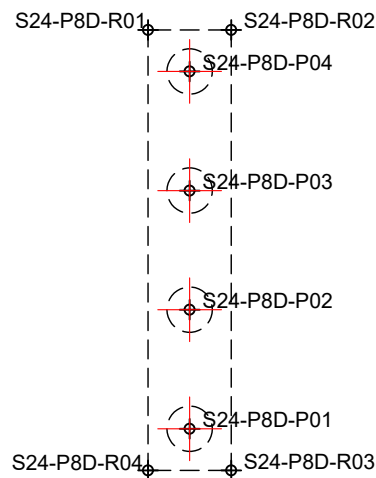
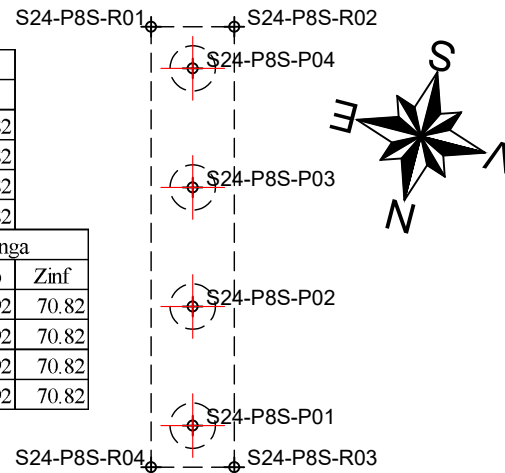

| TRASARE RADIER PILA "P8"- fir dreapta | | | |
|---------------------------------------|-----------|-----------|-------|
| Pct. | Y-(EST) | X-(NORD) | Z |
| S24-P8D-R01 | 241277.90 | 590922.79 | 90.76 |
| S24-P8D-R02 | 241275.77 | 590922.24 | 90.76 |
| S24-P8D-R03 | 241272.86 | 590933.52 | 90.76 |
| S24-P8D-R04 | 241274.99 | 590934.07 | 90.76 |

| TRASARE PILOTI PILA "P8"- fir dreapta | | | | |
|---------------------------------------|-----------|-----------|-------|-------|
| Pct. | Y-(EST) | X-(NORD) | Zsup | Zinf |
| S24-P8D-P01 | 241274.20 | 590932.73 | 90.86 | 70.76 |
| S24-P8D-P02 | 241274.99 | 590929.68 | 90.86 | 70.76 |
| S24-P8D-P03 | 241275.77 | 590926.63 | 90.86 | 70.76 |
| S24-P8D-P04 | 241276.56 | 590923.58 | 90.86 | 70.76 |

P8d

P9s

| TRASARE RADIER PILA "P9"- fir stanga | | | |
|--------------------------------------|-----------|-----------|-------|
| Pct. | Y-(EST) | X-(NORD) | Z |
| S24-P9S-R01 | 241233.71 | 590895.92 | 90.32 |
| S24-P9S-R02 | 241228.67 | 590894.63 | 90.32 |
| S24-P9S-R03 | 241225.78 | 590905.86 | 90.32 |
| S24-P9S-R04 | 241230.81 | 590907.16 | 90.32 |

| TRASARE PILOTI PILA "P9"- fir stanga | | | | |
|--------------------------------------|-----------|-----------|-------|-------|
| Pct. | Y-(EST) | X-(NORD) | Zsup | Zinf |
| S24-P9S-P01 | 241227.11 | 590905.09 | 90.42 | 74.32 |
| S24-P9S-P02 | 241230.01 | 590905.84 | 90.42 | 74.32 |
| S24-P9S-P03 | 241227.90 | 590902.04 | 90.42 | 74.32 |
| S24-P9S-P04 | 241230.80 | 590902.79 | 90.42 | 74.32 |
| S24-P9S-P05 | 241228.68 | 590898.99 | 90.42 | 74.32 |
| S24-P9S-P06 | 241231.59 | 590899.74 | 90.42 | 74.32 |
| S24-P9S-P07 | 241229.47 | 590895.94 | 90.42 | 74.32 |
| S24-P9S-P08 | 241232.37 | 590896.69 | 90.42 | 74.32 |

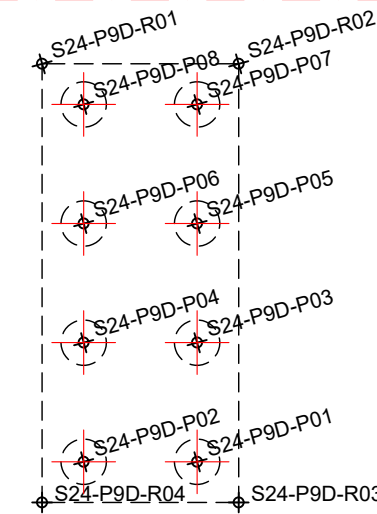
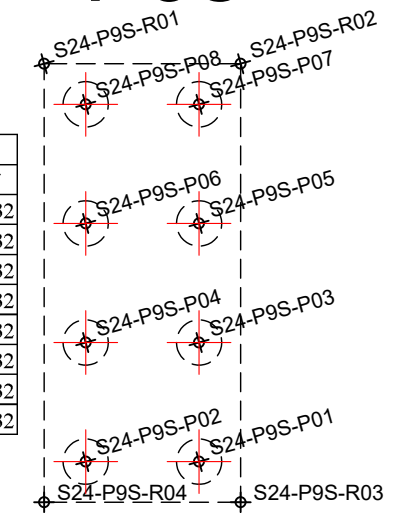

| TRASARE RADIER PILA "P9"- fir dreapta | | | |
|---------------------------------------|-----------|-----------|-------|
| Pct. | Y-(EST) | X-(NORD) | Z |
| S24-P9D-R01 | 241239.64 | 590912.95 | 90.27 |
| S24-P9D-R02 | 241234.61 | 590911.65 | 90.27 |
| S24-P9D-R03 | 241231.71 | 590922.88 | 90.27 |
| S24-P9D-R04 | 241236.75 | 590924.18 | 90.27 |

| TRASARE PILOTI PILA "P9"- fir dreapta | | | | |
|---------------------------------------|-----------|-----------|-------|-------|
| Pct. | Y-(EST) | X-(NORD) | Zsup | Zinf |
| S24-P9D-P01 | 241233.05 | 590922.11 | 90.37 | 74.27 |
| S24-P9D-P02 | 241235.95 | 590922.86 | 90.37 | 74.27 |
| S24-P9D-P03 | 241233.83 | 590919.06 | 90.37 | 74.27 |
| S24-P9D-P04 | 241236.74 | 590919.81 | 90.37 | 74.27 |
| S24-P9D-P05 | 241234.62 | 590916.01 | 90.37 | 74.27 |
| S24-P9D-P06 | 241237.52 | 590916.76 | 90.37 | 74.27 |
| S24-P9D-P07 | 241235.41 | 590912.96 | 90.37 | 74.27 |
| S24-P9D-P08 | 241238.31 | 590913.71 | 90.37 | 74.27 |

P9d

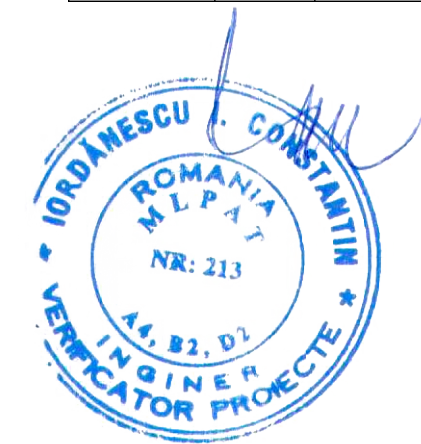
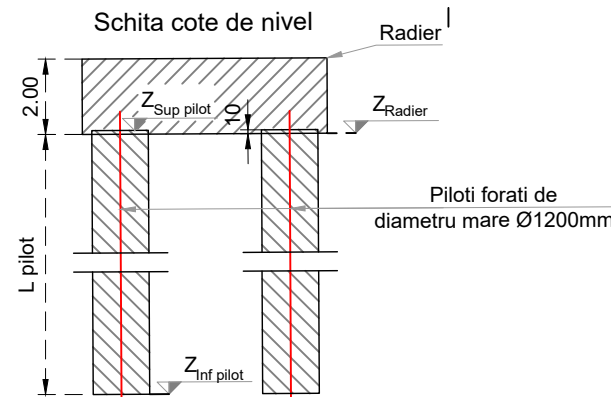

| | | | | | | | | | |
|--|---|--|--|--|---|--|--------------------------------|--|---|
| PROIECTANT / DESIGNER: S.C. CONSTRANS S.R.L. | BENEFICIAR / BENEFICIARY: MUNICIPIUL ARAD, MUNICIPIUL ORADEA, CONSILIUL JUDETEAN ARAD, CONSILIUL JUDETEAN BIHOR CNAIR | FUNCTIA / POSITION: COORDONATOR DE PROIECT / PROJECT MANAGER | NUME / NAME: ing. S. VEACESLAV | SEMNATURA / SIGNATURE: | Titlu plansa / Drawing title: Plan trasare - plan 5/11 Layout plan - plan 5/11 | REV. / REV.: R00 | DATA / DATE: 11.2023 | DETALII REVIZIE / REVISION DETAILS: P.T.E. | PROIECTAT / DESIGNER: Constrans |
| | | INVESTITIA / INVESTMENT: ACTUALIZARE/COMPLETARE/REVIZUIRE (S.F. + P.A.C. + P.O.E + P.T.E.) "DRUM EXPRES ARAD ORADEA" ACTUALIZATION/COMPLETION (S.F. + P.A.C. + P.O.E + P.T.E.) "EXPRESS ROAD ARAD ORADEA" | SEF PROIECT SPECIALITATE / TEAM LEADER: ing. D. COVELTIR | | Pod pe DX la km 41+055 peste DN79 si CF Bridge on DX at km 41+055 over DN79 and CF | | | | |
| | FAZA PROIECTARE / DESIGN STAGE: PROIECT TEHNIC DE EXECUTIE / EXECUTION TECHNICAL PROJECT | PROIECTAT / DESIGNER: ing. V. URDAREANU | | LUCRARI DE POD / BRIDGE WORKS | | | | | |
| | Contract /Contract: 14724/01.07.2021 Project /Project no.: 001/2021 | Data /Date: 11.2023 | Scara /Scale: 1:200 | VERIFICAT / INTERNAL CHECKER: ing. D. COVELTIR | | Cod plansa / Drawing code: CST-0121-PTE-02-DX- 02-P24-PTR-05-R00 | | | |

P10s

| TRASARE RADIER PILA "P10"- fir stanga | | | |
|---------------------------------------|-----------|-----------|-------|
| Pct. | Y-(EST) | X-(NORD) | Z |
| S24-P10S-R01 | 241202.24 | 590887.78 | 90.06 |
| S24-P10S-R02 | 241200.11 | 590887.24 | 90.06 |
| S24-P10S-R03 | 241197.20 | 590898.52 | 90.06 |
| S24-P10S-R04 | 241199.33 | 590899.07 | 90.06 |

| TRASARE PILOTI PILA "P10"- fir stanga | | | | |
|---------------------------------------|-----------|-----------|-------|-------|
| Pct. | Y-(EST) | X-(NORD) | Zsup | Zinf |
| S24-P10S-P01 | 241198.54 | 590897.73 | 90.16 | 74.06 |
| S24-P10S-P02 | 241199.33 | 590894.68 | 90.16 | 74.06 |
| S24-P10S-P03 | 241200.12 | 590891.63 | 90.16 | 74.06 |
| S24-P10S-P04 | 241200.90 | 590888.57 | 90.16 | 74.06 |

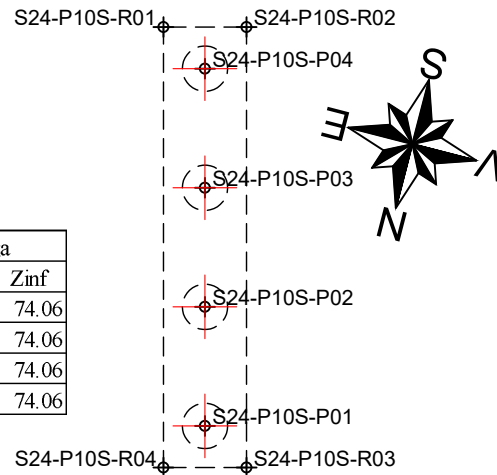

P11s

| TRASARE RADIER PILA "P11"- fir stanga | | | |
|---------------------------------------|-----------|-----------|-------|
| Pct. | Y-(EST) | X-(NORD) | Z |
| S24-P11S-R01 | 241162.06 | 590877.42 | 90.31 |
| S24-P11S-R02 | 241159.93 | 590876.87 | 90.31 |
| S24-P11S-R03 | 241157.02 | 590888.15 | 90.31 |
| S24-P11S-R04 | 241159.15 | 590888.70 | 90.31 |

| TRASARE PILOTI PILA "P11"- fir stanga | | | | |
|---------------------------------------|-----------|-----------|-------|-------|
| Pct. | Y-(EST) | X-(NORD) | Zsup | Zinf |
| S24-P11S-P01 | 241158.36 | 590887.36 | 90.41 | 74.31 |
| S24-P11S-P02 | 241159.14 | 590884.31 | 90.41 | 74.31 |
| S24-P11S-P03 | 241159.93 | 590881.26 | 90.41 | 74.31 |
| S24-P11S-P04 | 241160.72 | 590878.21 | 90.41 | 74.31 |

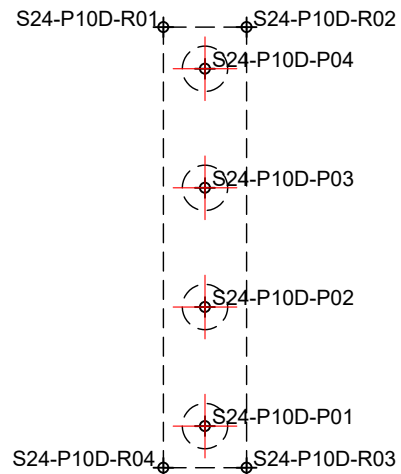
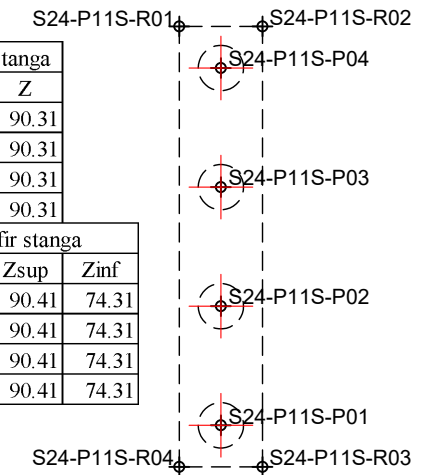

| TRASARE RADIER PILA "P10"- fir dreapta | | | |
|--|-----------|-----------|-------|
| Pct. | Y-(EST) | X-(NORD) | Z |
| S24-P10D-R01 | 241208.18 | 590904.81 | 90.12 |
| S24-P10D-R02 | 241206.05 | 590904.26 | 90.12 |
| S24-P10D-R03 | 241203.14 | 590915.54 | 90.12 |
| S24-P10D-R04 | 241205.27 | 590916.09 | 90.12 |

| TRASARE PILOTI PILA "P10"- fir dreapta | | | | |
|--|-----------|-----------|-------|-------|
| Pct. | Y-(EST) | X-(NORD) | Zsup | Zinf |
| S24-P10D-P01 | 241204.48 | 590914.75 | 90.22 | 74.12 |
| S24-P10D-P02 | 241205.27 | 590911.70 | 90.22 | 74.12 |
| S24-P10D-P03 | 241206.05 | 590908.65 | 90.22 | 74.12 |
| S24-P10D-P04 | 241206.84 | 590905.60 | 90.22 | 74.12 |

P10d



| TRASARE RADIER PILA "P11"- fir dreapta | | | |
|--|-----------|-----------|-------|
| Pct. | Y-(EST) | X-(NORD) | Z |
| S24-P11D-R01 | 241168.00 | 590894.44 | 90.23 |
| S24-P11D-R02 | 241165.87 | 590893.89 | 90.23 |
| S24-P11D-R03 | 241162.96 | 590905.17 | 90.23 |
| S24-P11D-R04 | 241165.09 | 590905.72 | 90.23 |

| TRASARE PILOTI PILA "P11"- fir dreapta | | | | |
|--|-----------|-----------|-------|-------|
| Pct. | Y-(EST) | X-(NORD) | Zsup | Zinf |
| S24-P11D-P01 | 241164.30 | 590904.38 | 90.33 | 74.23 |
| S24-P11D-P02 | 241165.08 | 590901.33 | 90.33 | 74.23 |
| S24-P11D-P03 | 241165.87 | 590898.28 | 90.33 | 74.23 |
| S24-P11D-P04 | 241166.66 | 590895.23 | 90.33 | 74.23 |

P11d

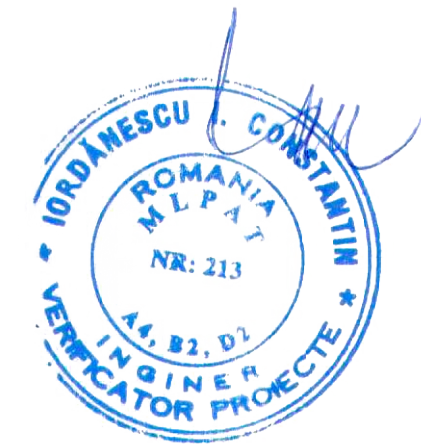
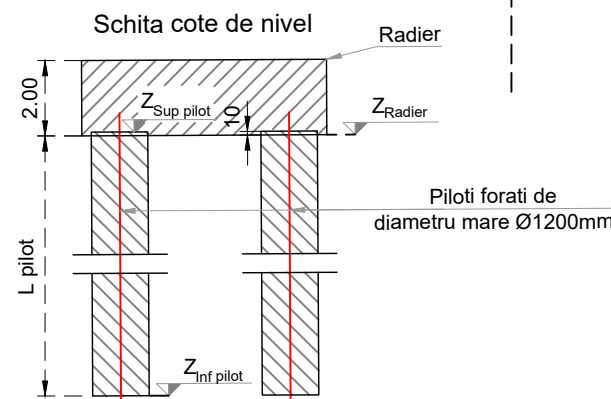

| | | | | | | | | | |
|---|---|--|--|--|---|--|--|--|---|
| PROIECTANT / DESIGNER: S.C. CONSITRANS S.R.L. | BENEFICIAR / BENEFICIARY: MUNICIPIUL ARAD, MUNICIPIUL ORADEA, CONSILIUL JUDETEAN ARAD, CONSILIUL JUDETEAN BIHOR CNAIR | FUNCTIA / POSITION: COORDONATOR DE PROIECT / PROJECT MANAGER | NUME / NAME: ing. S. VEACESLAV | SEMNETURA / SIGNATURE: | Titlu plansa / Drawing title: Plan trasare - plan 6/11 Layout plan - plan 6/11 | REV. / REV.: R00 | DATA / DATE: 11.2023 | DETALII REVIZIE / REVISION DETAILS: P.T.E. | PROIECTAT / DESIGNER: Consitrans |
| | | | | | | INVESTITIA / INVESTMENT: ACTUALIZARE/COMPLETARE/REVIZUIRE (S.F. + P.A.C. + P.O.E + P.T.E.) "DRUM EXPRES ARAD ORADEA" ACTUALIZATION/COMPLETION (S.F. + P.A.C. + P.O.E + P.T.E.) "EXPRESS ROAD ARAD ORADEA" | SEF PROIECT SPECIALITATE / TEAM LEADER: ing. D. COVELTIR | PROIECTAT / DESIGNER: ing. V. URDAREANU | LUCRARI DE POD / BRIDGE WORKS |
| | | FAZA PROIECTARE / DESIGN STAGE: PROIECT TEHNIC DE EXECUTIE / EXECUTION TECHNICAL PROJECT | PROIECTAT / DESIGNER: ing. D. COVELTIR | VERIFICAT / INTERNAL CHECKER: ing. D. COVELTIR | Cod plansa / Drawing code: CST-0121-PTE-02-DX- 02-P24-PTR-06-R00 | Contract / Contract: 14724/01.07.2021 | Data / Date: 11.2023 | Scara / Scale: 1:200 | PROIECT CO-FINANAT DIN FONDUL DE COEZIUNE, PRIN PROGRAMUL OPERATIONAL INFRASTRUCTURA MARE / PROJECT CO-FINANCED FROM THE COHESION FUND, THROUGH THE LARGE INFRASTRUCTURE OPERATIONAL PROGRAM |

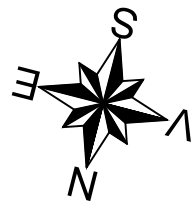

P12s

| TRASARE RADIER PILA "P12"- fir stanga | | | |
|---------------------------------------|-----------|-----------|-------|
| Pct. | Y-(EST) | X-(NORD) | Z |
| S24-P12S-R01 | 241121.87 | 590867.06 | 90.25 |
| S24-P12S-R02 | 241119.74 | 590866.51 | 90.25 |
| S24-P12S-R03 | 241116.83 | 590877.79 | 90.25 |
| S24-P12S-R04 | 241118.96 | 590878.34 | 90.25 |

| TRASARE PILOTI PILA "P12"- fir stanga | | | | |
|---------------------------------------|-----------|-----------|-------|-------|
| Pct. | Y-(EST) | X-(NORD) | Zsup | Zinf |
| S24-P12S-P01 | 241118.17 | 590877.00 | 90.35 | 74.25 |
| S24-P12S-P02 | 241118.96 | 590873.95 | 90.35 | 74.25 |
| S24-P12S-P03 | 241119.75 | 590870.90 | 90.35 | 74.25 |
| S24-P12S-P04 | 241120.53 | 590867.85 | 90.35 | 74.25 |

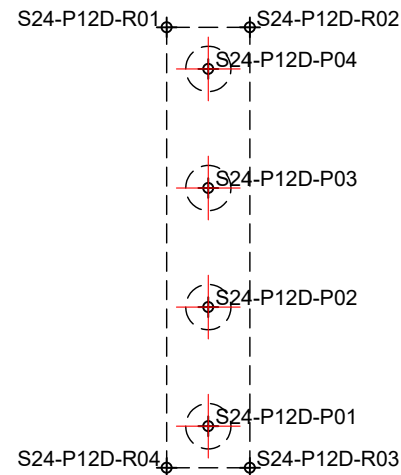
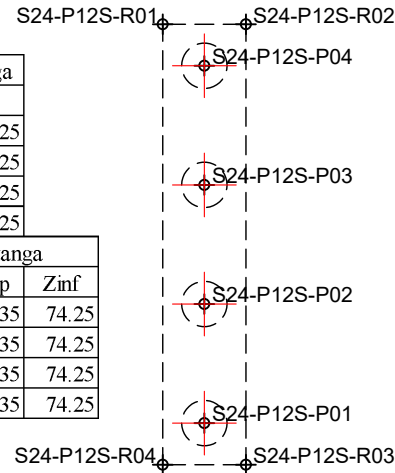

P12d

| TRASARE RADIER PILA "P12"- fir dreapta | | | |
|--|-----------|-----------|-------|
| Pct. | Y-(EST) | X-(NORD) | Z |
| S24-P12D-R01 | 241127.81 | 590884.08 | 90.25 |
| S24-P12D-R02 | 241125.68 | 590883.53 | 90.25 |
| S24-P12D-R03 | 241122.77 | 590894.81 | 90.25 |
| S24-P12D-R04 | 241124.90 | 590895.36 | 90.25 |

| TRASARE PILOTI PILA "P12"- fir dreapta | | | | |
|--|-----------|-----------|-------|-------|
| Pct. | Y-(EST) | X-(NORD) | Zsup | Zinf |
| S24-P12D-P01 | 241124.11 | 590894.02 | 90.35 | 74.25 |
| S24-P12D-P02 | 241124.90 | 590890.97 | 90.35 | 74.25 |
| S24-P12D-P03 | 241125.68 | 590887.92 | 90.35 | 74.25 |
| S24-P12D-P04 | 241126.47 | 590884.87 | 90.35 | 74.25 |

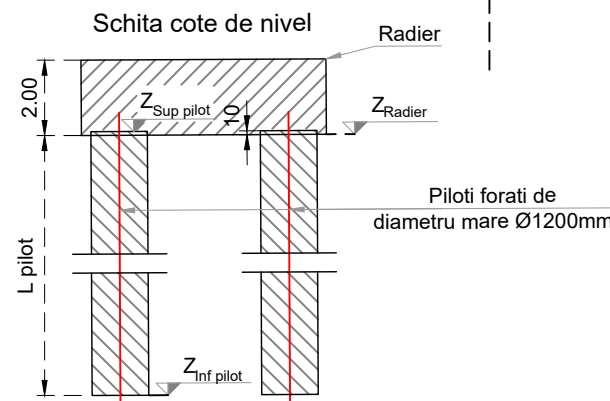

| TRASARE RADIER PILA "P13"- fir stanga | | | |
|---------------------------------------|-----------|-----------|-------|
| Pct. | Y-(EST) | X-(NORD) | Z |
| S24-P13S-R01 | 241083.86 | 590857.28 | 90.63 |
| S24-P13S-R02 | 241078.34 | 590855.86 | 90.63 |
| S24-P13S-R03 | 241075.44 | 590867.09 | 90.63 |
| S24-P13S-R04 | 241080.96 | 590868.51 | 90.63 |

| TRASARE PILOTI PILA "P13"- fir stanga | | | | |
|---------------------------------------|-----------|-----------|-------|-------|
| Pct. | Y-(EST) | X-(NORD) | Zsup | Zinf |
| S24-P13S-P01 | 241076.78 | 590866.32 | 90.73 | 74.63 |
| S24-P13S-P02 | 241080.17 | 590867.20 | 90.73 | 74.63 |
| S24-P13S-P03 | 241077.56 | 590863.27 | 90.73 | 74.63 |
| S24-P13S-P04 | 241080.95 | 590864.15 | 90.73 | 74.63 |
| S24-P13S-P05 | 241078.35 | 590860.22 | 90.73 | 74.63 |
| S24-P13S-P06 | 241081.74 | 590861.10 | 90.73 | 74.63 |
| S24-P13S-P07 | 241079.14 | 590857.17 | 90.73 | 74.63 |
| S24-P13S-P08 | 241082.53 | 590858.05 | 90.73 | 74.63 |

P13s

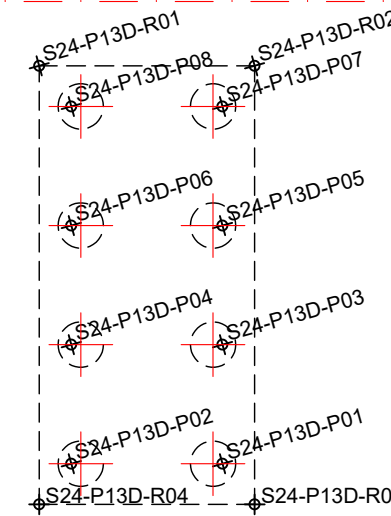
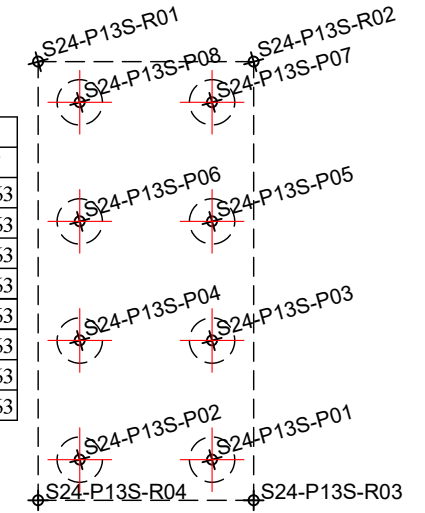

P13d

| TRASARE RADIER PILA "P13"- fir dreapta | | | |
|--|-----------|-----------|-------|
| Pct. | Y-(EST) | X-(NORD) | Z |
| S24-P13D-R01 | 241089.80 | 590874.30 | 90.65 |
| S24-P13D-R02 | 241084.28 | 590872.88 | 90.65 |
| S24-P13D-R03 | 241081.38 | 590884.11 | 90.65 |
| S24-P13D-R04 | 241086.90 | 590885.54 | 90.65 |

| TRASARE PILOTI PILA "P13"- fir dreapta | | | | |
|--|-----------|-----------|-------|-------|
| Pct. | Y-(EST) | X-(NORD) | Zsup | Zinf |
| S24-P13D-P01 | 241082.47 | 590883.28 | 90.75 | 74.65 |
| S24-P13D-P02 | 241086.35 | 590884.28 | 90.75 | 74.65 |
| S24-P13D-P03 | 241083.26 | 590880.23 | 90.75 | 74.65 |
| S24-P13D-P04 | 241087.13 | 590881.23 | 90.75 | 74.65 |
| S24-P13D-P05 | 241084.05 | 590877.18 | 90.75 | 74.65 |
| S24-P13D-P06 | 241087.92 | 590878.18 | 90.75 | 74.65 |
| S24-P13D-P07 | 241084.83 | 590874.13 | 90.75 | 74.65 |
| S24-P13D-P08 | 241088.71 | 590875.13 | 90.75 | 74.65 |



PROIECTANT / DESIGNER:
S.C. CONSTRANS S.R.L.



BENEFICIAR / BENEFICIARY:
MUNICIPIUL ARAD, MUNICIPIUL ORADEA, CONSILIUL JUDETEAN ARAD, CONSILIUL JUDETEAN BIHOR CNAIR

FUNCTIA / POSITION:

NUME / NAME:

SEMNETURA / SIGNATURE:

Titlu plansa / Drawing title:

REV/ REV.:

DATA / DATE:

DETALII REVIZIE / REVISION DETAILS:

PROIECTAT / DESIGNER:

S.C. CONSTRANS S.R.L.

ing. S. VEACESLAV

ing. D. COVELTIR

ing. V. URDAREANU

ing. D. COVELTIR

Plan trasare - plan 7/11
Layout plan - plan 7/11

R00

11.2023

P.T.E.

Constrans

INVESTITIA / INVESTMENT:
ACTUALIZARE/COMPLETARE/REVIZUIRE (S.F. + P.A.C. + P.O.E + P.T.E.) "DRUM EXPRES ARAD ORADEA"

COORDONATOR DE PROIECT / PROJECT MANAGER

ing. S. VEACESLAV

ing. D. COVELTIR

Pod pe DX la km 41+055 peste DN79 si CF
Bridge on DX at km 41+055 over DN79 and CF

ACTUALIZATION/COMPLETION (S.F. + P.A.C. + P.O.E + P.T.E.) "EXPRESS ROAD ARAD ORADEA"

SEF PROIECT SPECIALITATE / TEAM LEADER

ing. D. COVELTIR

ing. V. URDAREANU

LUCRARI DE POD / BRIDGE WORKS

FAZA PROIECTARE / DESIGN STAGE:
PROIECT TEHNIC DE EXECUTIE / EXECUTION TECHNICAL PROJECT

PROIECTAT / DESIGNER:

ing. V. URDAREANU

ing. D. COVELTIR

Cod plansa / Drawing code:

Contract / Contract: 14724/01.07.2021
Data / Date: 11.2023
Scara / Scale: 1:200

VERIFICAT / INTERNAL CHECKER:

ing. D. COVELTIR

CST-0121-PTE-02-DX- 02-P24-PTR-07-R00



UNIUNEA EUROPEANA



GUVERNUL ROMANIEI



Instrumente Structurale 2014-2020

PROIECT CO-FINANAT DIN FONDUL DE COEZIUNE, PRIN PROGRAMUL OPERATIONAL INFRASTRUCTURA MARE / PROJECT CO-FINANCED FROM THE COHESION FUND, THROUGH THE LARGE INFRASTRUCTURE OPERATIONAL PROGRAM

| TRASARE RADIER PILA "P14"- fir stanga | | | |
|---------------------------------------|-----------|-----------|-------|
| Pct. | Y-(EST) | X-(NORD) | Z |
| S24-P14S-R01 | 241035.20 | 590844.73 | 91.06 |
| S24-P14S-R02 | 241029.68 | 590843.31 | 91.06 |
| S24-P14S-R03 | 241026.79 | 590854.54 | 91.06 |
| S24-P14S-R04 | 241032.31 | 590855.97 | 91.06 |

| TRASARE PILOTI PILA "P14"- fir stanga | | | | |
|---------------------------------------|-----------|-----------|-------|-------|
| Pct. | Y-(EST) | X-(NORD) | Zsup | Zinf |
| S24-P14S-P01 | 241028.12 | 590853.78 | 91.16 | 75.06 |
| S24-P14S-P02 | 241031.51 | 590854.65 | 91.16 | 75.06 |
| S24-P14S-P03 | 241028.91 | 590850.73 | 91.16 | 75.06 |
| S24-P14S-P04 | 241032.30 | 590851.60 | 91.16 | 75.06 |
| S24-P14S-P05 | 241029.69 | 590847.68 | 91.16 | 75.06 |
| S24-P14S-P06 | 241033.08 | 590848.55 | 91.16 | 75.06 |
| S24-P14S-P07 | 241030.48 | 590844.63 | 91.16 | 75.06 |
| S24-P14S-P08 | 241033.87 | 590845.50 | 91.16 | 75.06 |

P14s

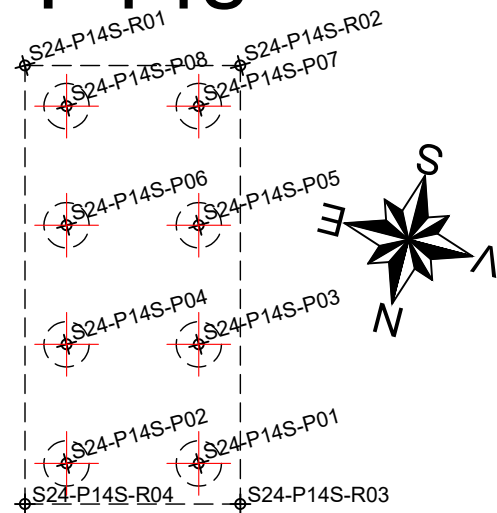

| TRASARE RADIER PILA "P15"- fir stanga | | | |
|---------------------------------------|-----------|-----------|-------|
| Pct. | Y-(EST) | X-(NORD) | Z |
| S24-P15S-R01 | 240977.10 | 590829.75 | 89.68 |
| S24-P15S-R02 | 240971.58 | 590828.33 | 89.68 |
| S24-P15S-R03 | 240968.69 | 590839.56 | 89.68 |
| S24-P15S-R04 | 240974.21 | 590840.98 | 89.68 |

| TRASARE PILOTI PILA "P15"- fir stanga | | | | |
|---------------------------------------|-----------|-----------|-------|-------|
| Pct. | Y-(EST) | X-(NORD) | Zsup | Zinf |
| S24-P15S-P01 | 240970.02 | 590838.79 | 89.78 | 73.68 |
| S24-P15S-P02 | 240973.41 | 590839.67 | 89.78 | 73.68 |
| S24-P15S-P03 | 240970.81 | 590835.74 | 89.78 | 73.68 |
| S24-P15S-P04 | 240974.20 | 590836.62 | 89.78 | 73.68 |
| S24-P15S-P05 | 240971.59 | 590832.69 | 89.78 | 73.68 |
| S24-P15S-P06 | 240974.98 | 590833.57 | 89.78 | 73.68 |
| S24-P15S-P07 | 240972.38 | 590829.64 | 89.78 | 73.68 |
| S24-P15S-P08 | 240975.77 | 590830.52 | 89.78 | 73.68 |

P15s

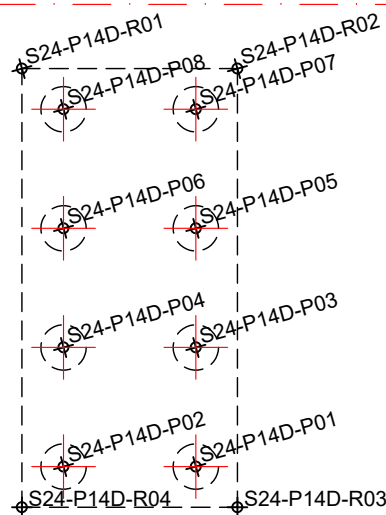
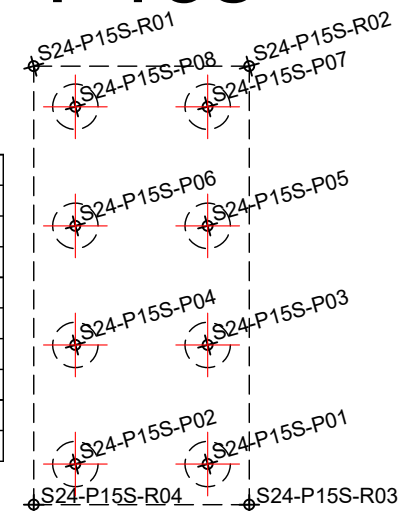

| TRASARE RADIER PILA "P14"- fir dreapta | | | |
|--|-----------|-----------|-------|
| Pct. | Y-(EST) | X-(NORD) | Z |
| S24-P14D-R01 | 241041.14 | 590861.75 | 91.11 |
| S24-P14D-R02 | 241035.62 | 590860.33 | 91.11 |
| S24-P14D-R03 | 241032.72 | 590871.56 | 91.11 |
| S24-P14D-R04 | 241038.24 | 590872.99 | 91.11 |

| TRASARE PILOTI PILA "P14"- fir dreapta | | | | |
|--|-----------|-----------|-------|-------|
| Pct. | Y-(EST) | X-(NORD) | Zsup | Zinf |
| S24-P14D-P01 | 241034.06 | 590870.80 | 91.21 | 75.11 |
| S24-P14D-P02 | 241037.45 | 590871.67 | 91.21 | 75.11 |
| S24-P14D-P03 | 241034.84 | 590867.75 | 91.21 | 75.11 |
| S24-P14D-P04 | 241038.23 | 590868.62 | 91.21 | 75.11 |
| S24-P14D-P05 | 241035.63 | 590864.70 | 91.21 | 75.11 |
| S24-P14D-P06 | 241039.02 | 590865.57 | 91.21 | 75.11 |
| S24-P14D-P07 | 241036.42 | 590861.65 | 91.21 | 75.11 |
| S24-P14D-P08 | 241039.81 | 590862.52 | 91.21 | 75.11 |

P14d

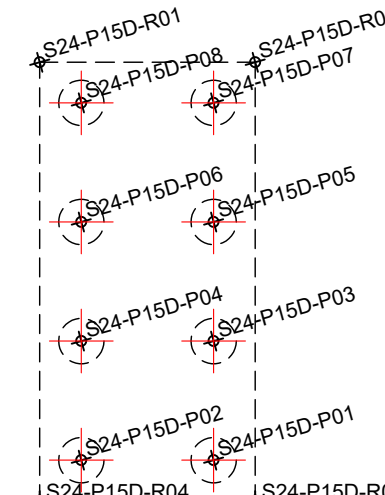

| TRASARE RADIER PILA "P15"- fir dreapta | | | |
|--|-----------|-----------|-------|
| Pct. | Y-(EST) | X-(NORD) | Z |
| S24-P15D-R01 | 240983.04 | 590846.77 | 89.75 |
| S24-P15D-R02 | 240977.52 | 590845.35 | 89.75 |
| S24-P15D-R03 | 240974.62 | 590856.58 | 89.75 |
| S24-P15D-R04 | 240980.14 | 590858.00 | 89.75 |

| TRASARE PILOTI PILA "P15"- fir dreapta | | | | |
|--|-----------|-----------|-------|-------|
| Pct. | Y-(EST) | X-(NORD) | Zsup | Zinf |
| S24-P15D-P01 | 240975.96 | 590855.81 | 89.85 | 73.75 |
| S24-P15D-P02 | 240979.35 | 590856.69 | 89.85 | 73.75 |
| S24-P15D-P03 | 240976.74 | 590852.76 | 89.85 | 73.75 |
| S24-P15D-P04 | 240980.13 | 590853.64 | 89.85 | 73.75 |
| S24-P15D-P05 | 240977.53 | 590849.71 | 89.85 | 73.75 |
| S24-P15D-P06 | 240980.92 | 590850.59 | 89.85 | 73.75 |
| S24-P15D-P07 | 240978.32 | 590846.66 | 89.85 | 73.75 |
| S24-P15D-P08 | 240981.71 | 590847.54 | 89.85 | 73.75 |

P15d

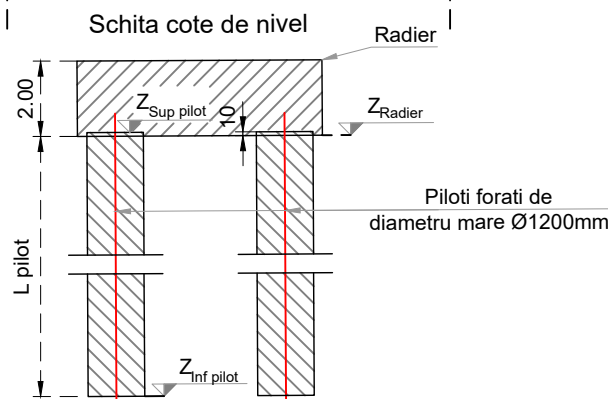
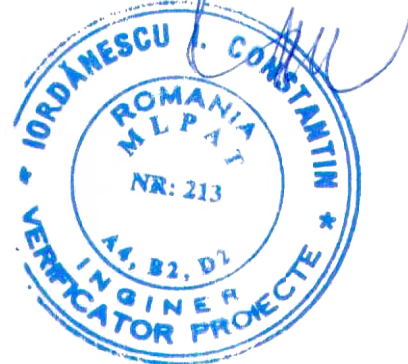

| | | | | | | | | | |
|--|---|--|--|--|---|--|--|--|--|
| PROIECTANT / DESIGNER: S.C. CONSITRANS S.R.L. | BENEFICIAR / BENEFICIARY: MUNICIPIUL ARAD, MUNICIPIUL ORADEA, CONSILIUL JUDETEAN ARAD, CONSILIUL JUDETEAN BIHOR CNAIR | FUNCTIA / POSITION: COORDONATOR DE PROIECT / PROJECT MANAGER | NUME / NAME: ing. S. VEACESLAV | SEMNTATURA / SIGNATURE: | Titlu plansa / Drawing title: Plan trasare - plan 8/11 Layout plan - plan 8/11 | REV/ REV.: R00 | DATA/ DATE: 11.2023 | DETALII REVIZIE / REVISION DETAILS: P.T.E. | PROIECTAT / DESIGNER: Consitrans |
| | | | | | | INVESTITIA / INVESTMENT: ACTUALIZARE/COMPLETARE/REVIZUIRE (S.F. + P.A.C. + P.O.E + P.T.E.) "DRUM EXPRES ARAD ORADEA" ACTUALIZATION/COMPLETION (S.F. + P.A.C. + P.O.E + P.T.E.) "EXPRESS ROAD ARAD ORADEA" | SEF PROIECT SPECIALITATE / TEAM LEADER: ing. D. COVELTIR | PROIECTAT / DESIGNER: ing. V. URDAREANU | Cod plansa / Drawing code: CST-0121-PTE-02-DX- 02-P24-PTR-08-R00 |
| FAZA PROIECTARE / DESIGN STAGE: PROIECT TEHNIC DE EXECUTIE / EXECUTION TECHNICAL PROJECT | Contract /Contract: 14724/01.07.2021 Project /Project no.: 001/2021 | Data / Date: 11.2023 | Scara /Scale: 1:200 | VERIFICAT / INTERNAL CHECKER: ing. D. COVELTIR | | | | | |



UNIUNEA EUROPEANA
 PROIECT CO-FINANAT DIN FONDUL DE COEZIUNE, PRIN PROGRAMUL OPERATIONAL INFRASTRUCTURA MARE /
 PROJECT CO-FINANCED FROM THE COHESION FUND, THROUGH THE LARGE INFRASTRUCTURE OPERATIONAL PROGRAM

Instrumente Structurale
 2014-2020

TRASARE RADIER PILA "P16"- fir stanga

| Pct. | Y-(EST) | X-(NORD) | Z |
|--------------|-----------|-----------|-------|
| S24-P16S-R01 | 240928.44 | 590817.20 | 91.12 |
| S24-P16S-R02 | 240922.93 | 590815.78 | 91.12 |
| S24-P16S-R03 | 240920.03 | 590827.01 | 91.12 |
| S24-P16S-R04 | 240925.55 | 590828.43 | 91.12 |

TRASARE PILOTI PILA "P16"- fir stanga

| Pct. | Y-(EST) | X-(NORD) | Zsup | Zinf |
|--------------|-----------|-----------|-------|-------|
| S24-P16S-P01 | 240921.36 | 590826.24 | 91.22 | 75.12 |
| S24-P16S-P02 | 240924.75 | 590827.12 | 91.22 | 75.12 |
| S24-P16S-P03 | 240922.15 | 590823.19 | 91.22 | 75.12 |
| S24-P16S-P04 | 240925.54 | 590824.07 | 91.22 | 75.12 |
| S24-P16S-P05 | 240922.94 | 590820.14 | 91.22 | 75.12 |
| S24-P16S-P06 | 240926.32 | 590821.02 | 91.22 | 75.12 |
| S24-P16S-P07 | 240923.72 | 590817.09 | 91.22 | 75.12 |
| S24-P16S-P08 | 240927.11 | 590817.97 | 91.22 | 75.12 |

P16s

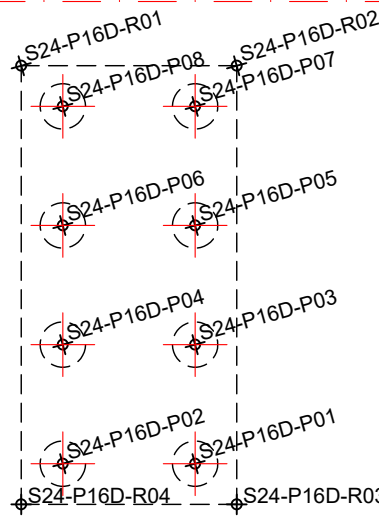
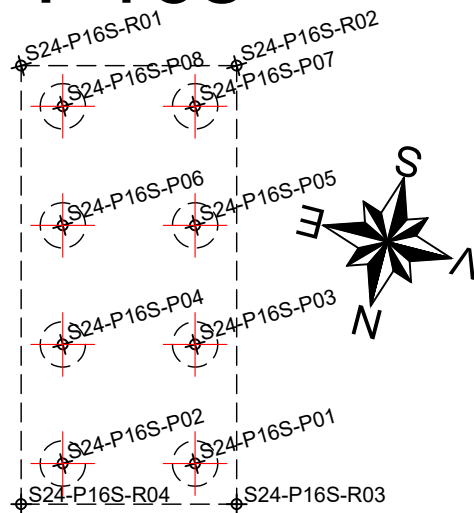

TRASARE RADIER PILA "P16"- fir dreapta

| Pct. | Y-(EST) | X-(NORD) | Z |
|--------------|-----------|-----------|-------|
| S24-P16D-R01 | 240934.38 | 590834.22 | 91.22 |
| S24-P16D-R02 | 240928.86 | 590832.80 | 91.22 |
| S24-P16D-R03 | 240925.97 | 590844.03 | 91.22 |
| S24-P16D-R04 | 240931.49 | 590845.46 | 91.22 |

TRASARE PILOTI PILA "P16"- fir dreapta

| Pct. | Y-(EST) | X-(NORD) | Zsup | Zinf |
|--------------|-----------|-----------|-------|-------|
| S24-P16D-P01 | 240927.30 | 590843.27 | 91.32 | 75.22 |
| S24-P16D-P02 | 240930.69 | 590844.14 | 91.32 | 75.22 |
| S24-P16D-P03 | 240928.09 | 590840.22 | 91.32 | 75.22 |
| S24-P16D-P04 | 240931.48 | 590841.09 | 91.32 | 75.22 |
| S24-P16D-P05 | 240928.87 | 590837.17 | 91.32 | 75.22 |
| S24-P16D-P06 | 240932.26 | 590838.04 | 91.32 | 75.22 |
| S24-P16D-P07 | 240929.66 | 590834.12 | 91.32 | 75.22 |
| S24-P16D-P08 | 240933.05 | 590834.99 | 91.32 | 75.22 |

P16d

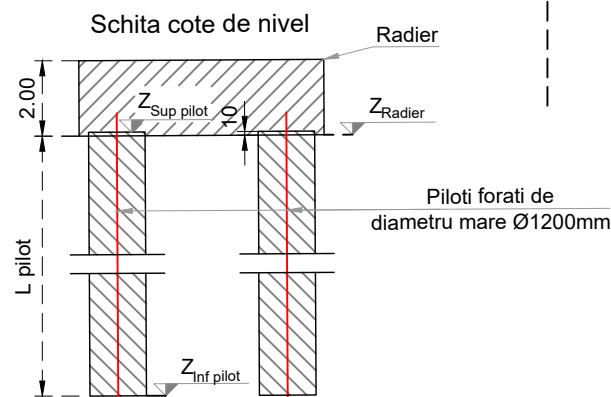

P17s

TRASARE RADIER PILA "P17"- fir stanga

| Pct. | Y-(EST) | X-(NORD) | Z |
|--------------|-----------|-----------|-------|
| S24-P17S-R01 | 240896.74 | 590809.00 | 91.33 |
| S24-P17S-R02 | 240894.61 | 590808.45 | 91.33 |
| S24-P17S-R03 | 240891.70 | 590819.73 | 91.33 |
| S24-P17S-R04 | 240893.83 | 590820.28 | 91.33 |

TRASARE PILOTI PILA "P17"- fir stanga

| Pct. | Y-(EST) | X-(NORD) | Zsup | Zinf |
|--------------|-----------|-----------|-------|-------|
| S24-P17S-P01 | 240893.04 | 590818.94 | 91.43 | 75.33 |
| S24-P17S-P02 | 240893.82 | 590815.89 | 91.43 | 75.33 |
| S24-P17S-P03 | 240894.61 | 590812.84 | 91.43 | 75.33 |
| S24-P17S-P04 | 240895.40 | 590809.79 | 91.43 | 75.33 |

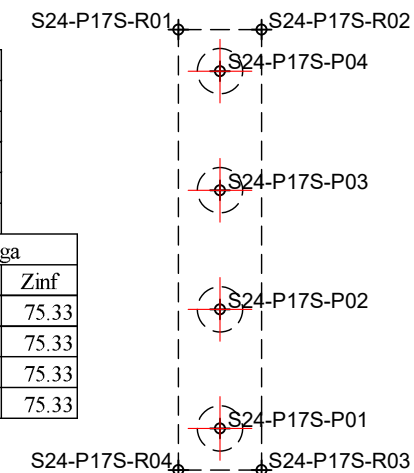

TRASARE RADIER PILA "P17"- fir dreapta

| Pct. | Y-(EST) | X-(NORD) | Z |
|--------------|-----------|-----------|-------|
| S24-P17D-R01 | 240892.99 | 590823.53 | 91.33 |
| S24-P17D-R02 | 240890.86 | 590822.98 | 91.33 |
| S24-P17D-R03 | 240887.95 | 590834.26 | 91.33 |
| S24-P17D-R04 | 240890.08 | 590834.81 | 91.33 |

TRASARE PILOTI PILA "P17"- fir dreapta

| Pct. | Y-(EST) | X-(NORD) | Zsup | Zinf |
|--------------|-----------|-----------|-------|-------|
| S24-P17D-P01 | 240889.29 | 590833.47 | 91.43 | 75.33 |
| S24-P17D-P02 | 240890.08 | 590830.42 | 91.43 | 75.33 |
| S24-P17D-P03 | 240890.87 | 590827.37 | 91.43 | 75.33 |
| S24-P17D-P04 | 240891.65 | 590824.32 | 91.43 | 75.33 |

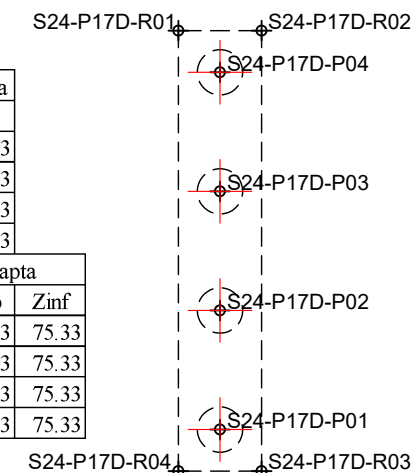

P17d

PROIECTANT / DESIGNER:
S.C. CONSITRANS S.R.L.



BENEFICIAR / BENEFICIARY:
MUNICIPIUL ARAD, MUNICIPIUL ORADEA, CONSILIUL JUDETEAN ARAD, CONSILIUL JUDETEAN BIHOR CNAIR

FUNCTIA / POSITION:
COORDONATOR DE PROIECT / PROJECT MANAGER

NUME / NAME:
ing. S. VEACESLAV

SEMNATURA / SIGNATURE:
[Signature]

Titlu plansa / Drawing title:
Plan trasare - plan 9/11
Layout plan - plan 9/11

REV. / REV.:
R00

DATA / DATE:
11.2023

DETALII REVIZIE / REVISION DETAILS:
P.T.E.

PROIECTAT / DESIGNER:
Consitrans

INVESTITIA / INVESTMENT:
ACTUALIZARE/COMPLETARE/REVIZUIRE (S.F. + P.A.C. + P.O.E + P.T.E.) "DRUM EXPRES ARAD ORADEA"
ACTUALIZATION/COMPLETION (S.F. + P.A.C. + P.O.E + P.T.E.) "EXPRESS ROAD ARAD ORADEA"

SEF PROIECT SPECIALITATE / TEAM LEADER
ing. D. COVELTIR

SEMNATURA / SIGNATURE:
[Signature]

Pod pe DX la km 41+055 peste DN79 si CF
Bridge on DX at km 41+055 over DN79 and CF

REV. / REV.:

DATA / DATE:

DETALII REVIZIE / REVISION DETAILS:

PROIECTAT / DESIGNER:

FAZA PROIECTARE / DESIGN STAGE:
PROIECT TEHNIC DE EXECUTIE / EXECUTION TECHNICAL PROJECT

PROIECTAT / DESIGNER:
ing. V. URDAREANU

SEMNATURA / SIGNATURE:
[Signature]

LUCRARI DE POD / BRIDGE WORKS

REV. / REV.:

DATA / DATE:

DETALII REVIZIE / REVISION DETAILS:

PROIECTAT / DESIGNER:

Contract / Contract: 14724/01.07.2021
Data / Date: 11.2023
Scara / Scale: 1:200

VERIFICAT / INTERNAL CHECKER:
ing. D. COVELTIR

SEMNATURA / SIGNATURE:
[Signature]

Cod plansa / Drawing code:
CST-0121-PTE-02-DX- 02-P24-PTR-09-R00



PROIECT CO-FINANAT DIN FONDUL DE COEZIUNE, PRIN PROGRAMUL OPERATIONAL INFRASTRUCTURA MARE / PROJECT CO-FINANCED FROM THE COHESION FUND, THROUGH THE LARGE INFRASTRUCTURE OPERATIONAL PROGRAM

P18s

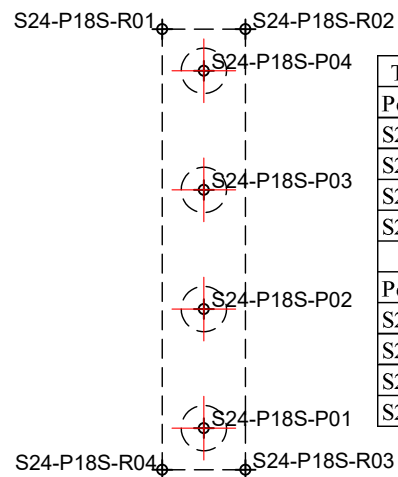
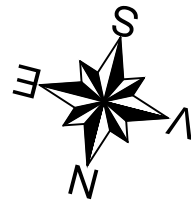

| TRASARE RADIER PILA "P18"- fir stanga | | | | |
|---------------------------------------|-----------|-----------|-------|-------|
| Pct. | Y-(EST) | X-(NORD) | Z | |
| S24-P18S-R01 | 240856.55 | 590798.64 | 91.32 | |
| S24-P18S-R02 | 240854.42 | 590798.09 | 91.32 | |
| S24-P18S-R03 | 240851.51 | 590809.37 | 91.32 | |
| S24-P18S-R04 | 240853.64 | 590809.92 | 91.32 | |
| TRASARE PILOTI PILA "P18"- fir stanga | | | | |
| Pct. | Y-(EST) | X-(NORD) | Zsup | Zinf |
| S24-P18S-P01 | 240852.85 | 590808.58 | 91.42 | 75.32 |
| S24-P18S-P02 | 240853.64 | 590805.53 | 91.42 | 75.32 |
| S24-P18S-P03 | 240854.43 | 590802.48 | 91.42 | 75.32 |
| S24-P18S-P04 | 240855.21 | 590799.43 | 91.42 | 75.32 |

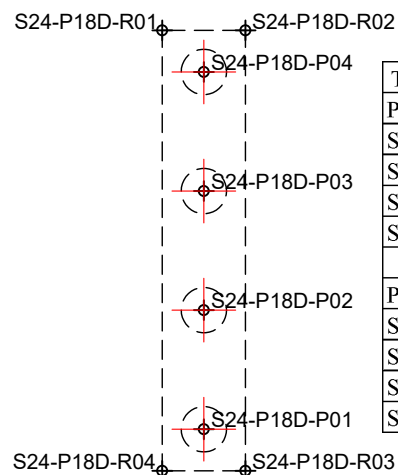

| TRASARE RADIER PILA "P18"- fir dreapta | | | | |
|--|-----------|-----------|-------|-------|
| Pct. | Y-(EST) | X-(NORD) | Z | |
| S24-P18D-R01 | 240852.81 | 590813.16 | 91.32 | |
| S24-P18D-R02 | 240850.68 | 590812.61 | 91.32 | |
| S24-P18D-R03 | 240847.77 | 590823.89 | 91.32 | |
| S24-P18D-R04 | 240849.90 | 590824.44 | 91.32 | |
| TRASARE PILOTI PILA "P18"- fir dreapta | | | | |
| Pct. | Y-(EST) | X-(NORD) | Zsup | Zinf |
| S24-P18D-P01 | 240849.11 | 590823.10 | 91.42 | 75.32 |
| S24-P18D-P02 | 240849.89 | 590820.05 | 91.42 | 75.32 |
| S24-P18D-P03 | 240850.68 | 590817.00 | 91.42 | 75.32 |
| S24-P18D-P04 | 240851.47 | 590813.95 | 91.42 | 75.32 |

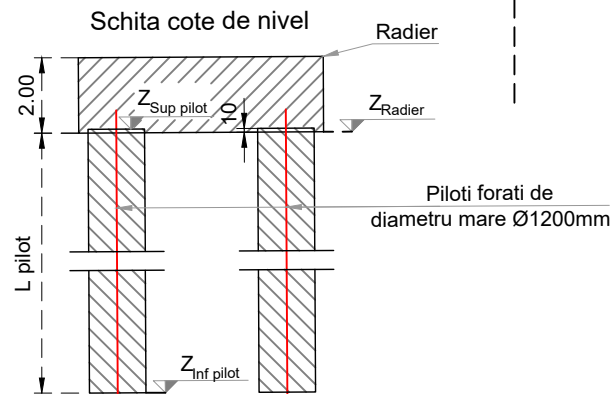

P19s

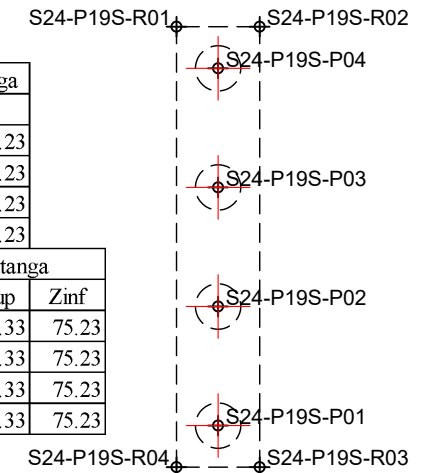

| TRASARE RADIER PILA "P19"- fir stanga | | | | |
|---------------------------------------|-----------|-----------|-------|-------|
| Pct. | Y-(EST) | X-(NORD) | Z | |
| S24-P19S-R01 | 240816.37 | 590788.27 | 91.23 | |
| S24-P19S-R02 | 240814.24 | 590787.72 | 91.23 | |
| S24-P19S-R03 | 240811.33 | 590799.00 | 91.23 | |
| S24-P19S-R04 | 240813.46 | 590799.55 | 91.23 | |
| TRASARE PILOTI PILA "P19"- fir stanga | | | | |
| Pct. | Y-(EST) | X-(NORD) | Zsup | Zinf |
| S24-P19S-P01 | 240812.67 | 590798.21 | 91.33 | 75.23 |
| S24-P19S-P02 | 240813.45 | 590795.16 | 91.33 | 75.23 |
| S24-P19S-P03 | 240814.24 | 590792.11 | 91.33 | 75.23 |
| S24-P19S-P04 | 240815.03 | 590789.06 | 91.33 | 75.23 |

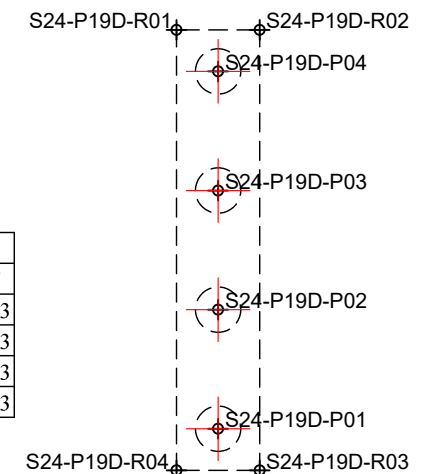

| TRASARE RADIER PILA "P19"- fir dreapta | | | | |
|--|-----------|-----------|-------|-------|
| Pct. | Y-(EST) | X-(NORD) | Z | |
| S24-P19D-R01 | 240812.62 | 590802.80 | 91.23 | |
| S24-P19D-R02 | 240810.49 | 590802.25 | 91.23 | |
| S24-P19D-R03 | 240807.58 | 590813.53 | 91.23 | |
| S24-P19D-R04 | 240809.71 | 590814.08 | 91.23 | |
| TRASARE PILOTI PILA "P19"- fir dreapta | | | | |
| Pct. | Y-(EST) | X-(NORD) | Zsup | Zinf |
| S24-P19D-P01 | 240808.92 | 590812.74 | 91.33 | 75.23 |
| S24-P19D-P02 | 240809.71 | 590809.69 | 91.33 | 75.23 |
| S24-P19D-P03 | 240810.50 | 590806.64 | 91.33 | 75.23 |
| S24-P19D-P04 | 240811.28 | 590803.59 | 91.33 | 75.23 |

P19d

PROIECTANT / DESIGNER:
S.C. CONSTRANS S.R.L.



BENEFICIAR / BENEFICIARY:
MUNICIPIUL ARAD, MUNICIPIUL ORADEA, CONSILIUL JUDETEAN ARAD, CONSILIUL JUDETEAN BIHOR CNAIR

FUNCTIA / POSITION:
COORDONATOR DE PROIECT / PROJECT MANAGER

NUME / NAME:
ing. S. VEACESLAV

SEMNETURA / SIGNATURE:
[Signature]

Titlu plansa / Drawing title:
Plan trasare - plan 10/11
Layout plan - plan 10/11

REV. / REV.:
R00

DATA / DATE:
11.2023

DETALII REVIZIE / REVISION DETAILS:
P.T.E.

PROIECTAT / DESIGNER:
Constrans

INVESTITIA / INVESTMENT:
ACTUALIZARE/COMPLETARE/REVIZUIRE (S.F. + P.A.C. + P.O.E + P.T.E.) "DRUM EXPRES ARAD ORADEA"
ACTUALIZATION/COMPLETION (S.F. + P.A.C. + P.O.E + P.T.E.) "EXPRESS ROAD ARAD ORADEA"

SEF PROIECT SPECIALITATE / TEAM LEADER

ing. D. COVELTIR

[Signature]

Pod pe DX la km 41+055 peste DN79 si CF
Bridge on DX at km 41+055 over DN79 and CF

FAZA PROIECTARE / DESIGN STAGE:
PROIECT TEHNIC DE EXECUTIE / EXECUTION TECHNICAL PROJECT

PROIECTAT / DESIGNER:

ing. V. URDAREANU

[Signature]

LUCRARI DE POD / BRIDGE WORKS

Contract /Contract: 14724/01.07.2021
Data /Date: 11.2023
Scara /Scale: 1:200

VERIFICAT / INTERNAL CHECKER:

ing. D. COVELTIR

[Signature]

Cod plansa / Drawing code:
CST-0121-PTE-02-DX- 02-P24-PTR-10-R00



UNIUNEA EUROPEANA



GUVERNUL ROMANIEI



Instrumente Structurale 2014-2020

PROIECT CO-FINANAT DIN FONDUL DE COEZIUNE, PRIN PROGRAMUL OPERATIONAL INFRASTRUCTURA MARE / PROJECT CO-FINANCED FROM THE COHESION FUND, THROUGH THE LARGE INFRASTRUCTURE OPERATIONAL PROGRAM



| TRASARE RADIER CULEE "C2"-fir stg | | | |
|-----------------------------------|-----------|-----------|-------|
| Pct. | X-(EST) | Y-(NORD) | Z |
| S24-C2S-R01 | 240781.41 | 590779.26 | 91.23 |
| S24-C2S-R02 | 240773.18 | 590777.14 | 91.23 |
| S24-C2S-R03 | 240770.27 | 590788.42 | 91.23 |
| S24-C2S-R04 | 240778.50 | 590790.54 | 91.23 |

| TRASARE PILOTI CULEE "C2"-fir stg | | | | |
|-----------------------------------|-----------|-----------|-------|-------|
| Pct. | X-(EST) | Y-(NORD) | Zsup | Zinf |
| S24-C2S-P01 | 240771.61 | 590787.63 | 91.33 | 75.23 |
| S24-C2S-P02 | 240774.66 | 590788.41 | 91.33 | 75.23 |
| S24-C2S-P03 | 240777.71 | 590789.20 | 91.33 | 75.23 |
| S24-C2S-P04 | 240772.40 | 590784.58 | 91.33 | 75.23 |
| S24-C2S-P05 | 240775.45 | 590785.36 | 91.33 | 75.23 |
| S24-C2S-P06 | 240778.50 | 590786.15 | 91.33 | 75.23 |
| S24-C2S-P07 | 240773.18 | 590781.53 | 91.33 | 75.23 |
| S24-C2S-P08 | 240776.24 | 590782.31 | 91.33 | 75.23 |
| S24-C2S-P09 | 240779.29 | 590783.10 | 91.33 | 75.23 |
| S24-C2S-P10 | 240773.97 | 590778.48 | 91.33 | 75.23 |
| S24-C2S-P11 | 240777.02 | 590779.26 | 91.33 | 75.23 |
| S24-C2S-P12 | 240780.07 | 590780.05 | 91.33 | 75.23 |

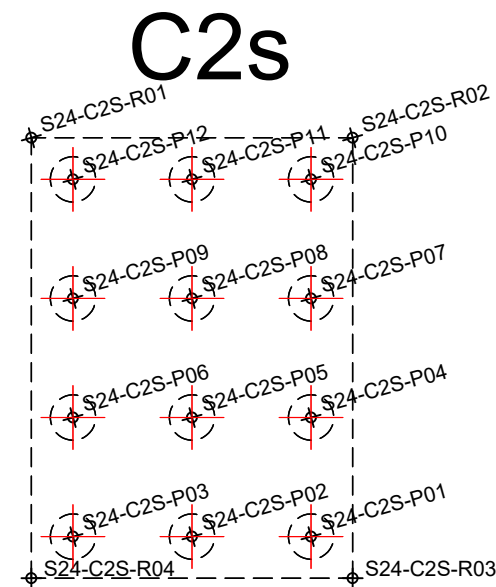

| TRASARE RADIER CULEE "C2"-fir dr | | | |
|----------------------------------|-----------|-----------|-------|
| Pct. | X-(EST) | Y-(NORD) | Z |
| S24-C2D-R01 | 240777.67 | 590793.78 | 91.23 |
| S24-C2D-R02 | 240769.44 | 590791.66 | 91.23 |
| S24-C2D-R03 | 240766.53 | 590802.94 | 91.23 |
| S24-C2D-R04 | 240774.76 | 590805.06 | 91.23 |

| TRASARE PILOTI CULEE "C2"-fir dr | | | | |
|----------------------------------|-----------|-----------|-------|-------|
| Pct. | X-(EST) | Y-(NORD) | Zsup | Zinf |
| S24-C2D-P01 | 240767.87 | 590802.15 | 91.33 | 75.23 |
| S24-C2D-P02 | 240770.92 | 590802.94 | 91.33 | 75.23 |
| S24-C2D-P03 | 240773.97 | 590803.72 | 91.33 | 75.23 |
| S24-C2D-P04 | 240768.65 | 590799.10 | 91.33 | 75.23 |
| S24-C2D-P05 | 240771.70 | 590799.89 | 91.33 | 75.23 |
| S24-C2D-P06 | 240774.75 | 590800.67 | 91.33 | 75.23 |
| S24-C2D-P07 | 240769.44 | 590796.05 | 91.33 | 75.23 |
| S24-C2D-P08 | 240772.49 | 590796.84 | 91.33 | 75.23 |
| S24-C2D-P09 | 240775.54 | 590797.62 | 91.33 | 75.23 |
| S24-C2D-P10 | 240770.23 | 590793.00 | 91.33 | 75.23 |
| S24-C2D-P11 | 240773.28 | 590793.79 | 91.33 | 75.23 |
| S24-C2D-P12 | 240776.33 | 590794.57 | 91.33 | 75.23 |

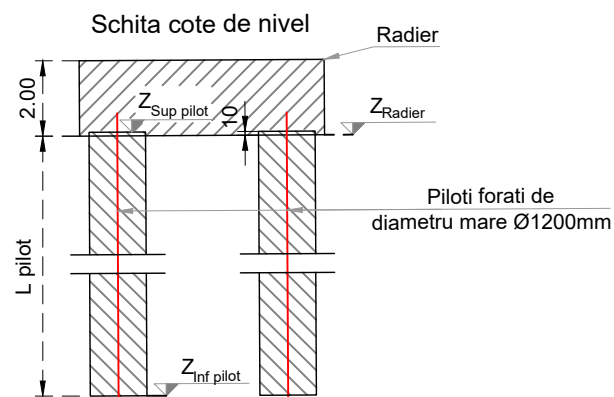
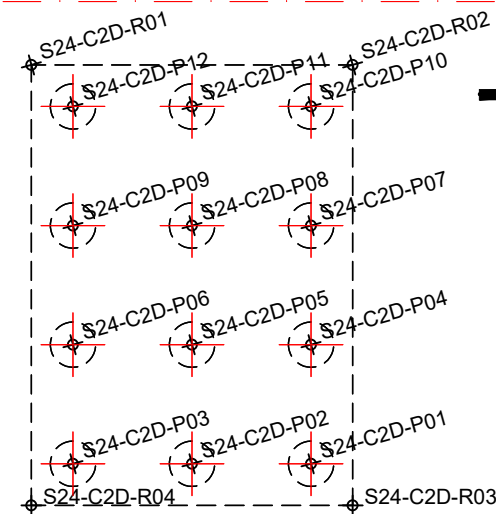

PROIECTANT / DESIGNER:
S.C. CONSTRANS S.R.L.



BENEFICIAR / BENEFICIARY:
MUNICIPIUL ARAD, MUNICIPIUL ORADEA, CONSILIUL JUDETEAN ARAD, CONSILIUL JUDETEAN BIHOR CNAIR

FUNCTIA / POSITION:
COORDONATOR DE PROIECT / PROJECT MANAGER

NUME / NAME:
ing. S. VEACESLAV

SEMNATURA / SIGNATURE:
[Signature]

Titlu plansa / Drawing title:
Plan trasare - plan 11/11
Layout plan - plan 11/11

REV/ REV.:
R00

DATA/ DATE:
11.2023

DETALII REVIZIE / REVISION DETAILS:
P.T.E.

PROIECTAT / DESIGNER:
Constrans

INVESTITIA / INVESTMENT:
ACTUALIZARE/COMPLETARE/REVIZUIRE (S.F. + P.A.C. + P.O.E + P.T.E.) "DRUM EXPRES ARAD ORADEA"
ACTUALIZATION/COMPLETION (S.F. + P.A.C. + P.O.E + P.T.E.) "EXPRESS ROAD ARAD ORADEA"

SEF PROIECT SPECIALITATE / TEAM LEADER
ing. D. COVELTIR

SEMNATURA / SIGNATURE:
[Signature]

Pod pe DX la km 41+055 peste DN79 si CF
Bridge on DX at km 41+055 over DN79 and CF

FAZA PROIECTARE / DESIGN STAGE:
PROIECT TEHNIC DE EXECUTIE / EXECUTION TECHNICAL PROJECT

PROIECTAT / DESIGNER:
ing. V. URDAREANU

SEMNATURA / SIGNATURE:
[Signature]

LUCRARI DE POD / BRIDGE WORKS

Contract /Contract: 14724/01.07.2021
Data / Date: 11.2023
Scara /Scale: 1:200

VERIFICAT / INTERNAL CHECKER:
ing. D. COVELTIR

SEMNATURA / SIGNATURE:
[Signature]

Cod plansa / Drawing code:
CST-0121-PTE-02-DX- 02-P24-PTR-11-R00



UNIUNEA EUROPEANA



GUVERNUL ROMANIEI



Instrumente Structurale 2014-2020

PROIECT CO-FINANAT DIN FONDUL DE COEZIUNE, PRIN PROGRAMUL OPERATIONAL INFRASTRUCTURA MARE / PROJECT CO-FINANCED FROM THE COHESION FUND, THROUGH THE LARGE INFRASTRUCTURE OPERATIONAL PROGRAM