

Oradea ←

C1

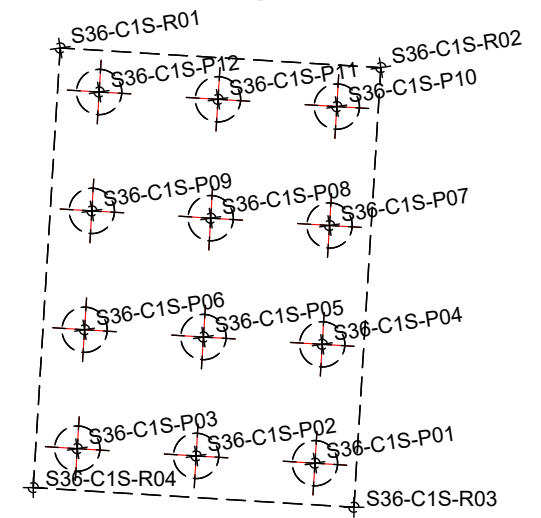

TRASARE RADIER CULEE "C1"-fir dr				
Pct.	X-(EST)	Y-(NORD)	Z	
S36-C1D-R01	231405.59	578617.67	87.57	
S36-C1D-R02	231400.75	578610.64	87.57	
S36-C1D-R03	231390.89	578616.84	87.57	
S36-C1D-R04	231395.41	578624.04	87.57	

TRASARE PILOTI CULEE "C1"-fir dr				
Pct.	X-(EST)	Y-(NORD)	Zsup	Zinf
S36-C1D-P01	231392.40	578617.18	87.67	67.57
S36-C1D-P02	231394.08	578619.85	87.67	67.57
S36-C1D-P03	231395.75	578622.52	87.67	67.57
S36-C1D-P04	231395.07	578615.51	87.67	67.57
S36-C1D-P05	231396.75	578618.18	87.67	67.57
S36-C1D-P06	231398.42	578620.84	87.67	67.57
S36-C1D-P07	231397.74	578613.83	87.67	67.57
S36-C1D-P08	231399.41	578616.50	87.67	67.57
S36-C1D-P09	231400.92	578619.26	87.67	67.57
S36-C1D-P10	231400.41	578612.16	87.67	67.57
S36-C1D-P11	231402.08	578614.83	87.67	67.57
S36-C1D-P12	231403.76	578617.49	87.67	67.57

TRASARE RADIER CULEE "C1"- bretea			
Pct.	X-(EST)	Y-(NORD)	Z
S36-C1'D-R01	231391.20	578626.26	87.57
S36-C1'D-R02	231389.65	578620.77	87.57
S36-C1'D-R03	231381.47	578623.10	87.57
S36-C1'D-R04	231383.03	578628.58	87.57

TRASARE PILOTI CULEE "C1"-fir dr				
Pct.	X-(EST)	Y-(NORD)	Zsup	Zinf
S36-C1'D-P01	231382.83	578623.85	87.67	67.57
S36-C1'D-P02	231383.78	578627.22	87.67	67.57
S36-C1'D-P03	231385.86	578622.99	87.67	67.57
S36-C1'D-P04	231386.81	578626.36	87.67	67.57
S36-C1'D-P05	231388.89	578622.13	87.67	67.57
S36-C1'D-P06	231389.84	578625.50	87.67	67.57

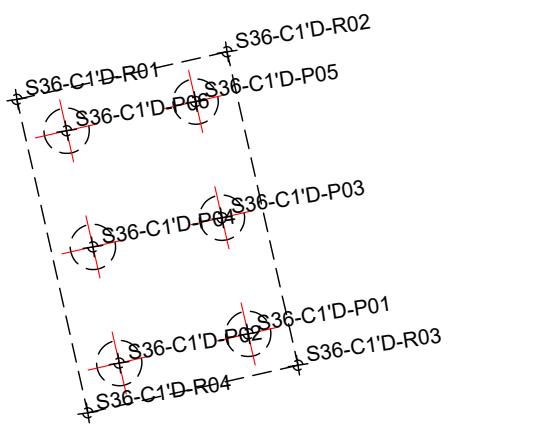
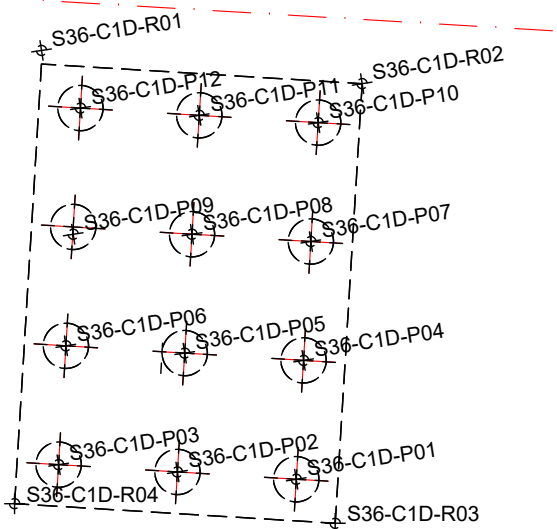

TRASARE RADIER CULEE "C1"-fir stg			
Pct.	X-(EST)	Y-(NORD)	Z
S36-C1S-R01	231417.98	578609.87	87.57
S36-C1S-R02	231413.46	578602.67	87.57
S36-C1S-R03	231403.59	578608.86	87.57
S36-C1S-R04	231408.11	578616.06	87.57

TRASARE PILOTI CULEE "C1"-fir stg				
Pct.	X-(EST)	Y-(NORD)	Zsup	Zinf
S36-C1S-P01	231405.11	578609.21	87.67	67.57
S36-C1S-P02	231406.78	578611.88	87.67	67.57
S36-C1S-P03	231408.46	578614.54	87.67	67.57
S36-C1S-P04	231407.78	578607.53	87.67	67.57
S36-C1S-P05	231409.45	578610.20	87.67	67.57
S36-C1S-P06	231411.13	578612.87	87.67	67.57
S36-C1S-P07	231410.44	578605.86	87.67	67.57
S36-C1S-P08	231412.12	578608.53	87.67	67.57
S36-C1S-P09	231413.79	578611.19	87.67	67.57
S36-C1S-P10	231413.11	578604.18	87.67	67.57
S36-C1S-P11	231414.79	578606.85	87.67	67.57
S36-C1S-P12	231416.46	578609.52	87.67	67.57



P1

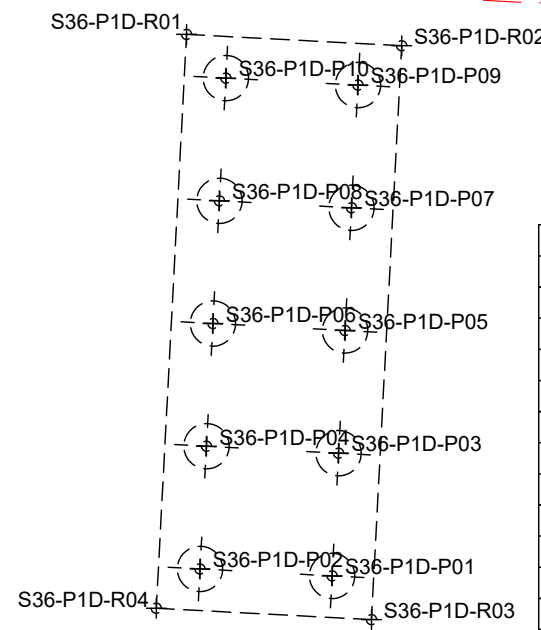
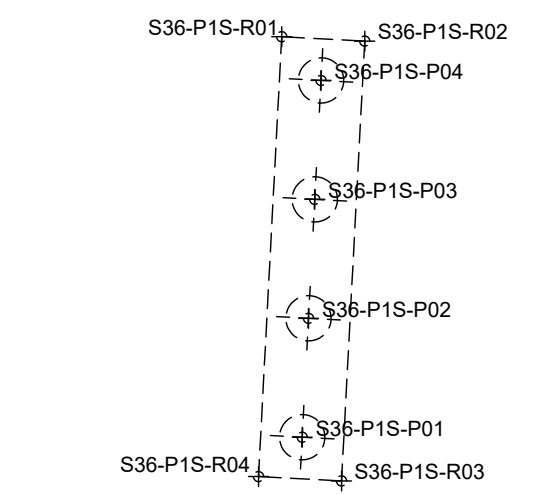

TRASARE RADIER PILA "P1"- fir stanga			
Pct.	Y-(EST)	X-(NORD)	Z
S36-P1S-R01	231395.63	578573.97	87.22
S36-P1S-R02	231394.48	578572.09	87.22
S36-P1S-R03	231384.56	578578.20	87.22
S36-P1S-R04	231385.71	578580.08	87.22

TRASARE PILOTI PILA "P1"- fir stanga				
Pct.	Y-(EST)	X-(NORD)	Zsup	Zinf
S36-P1S-P01	231386.07	578578.56	87.32	67.22
S36-P1S-P02	231388.76	578576.91	87.32	67.22
S36-P1S-P03	231391.44	578575.26	87.32	67.22
S36-P1S-P04	231394.12	578573.61	87.32	67.22

TRASARE RADIER PILA "P1"- fir dreapta			
Pct.	Y-(EST)	X-(NORD)	Z
S36-P1D-R01	231382.86	578581.83	86.79
S36-P1D-R02	231381.71	578579.96	86.79
S36-P1D-R03	231371.79	578586.07	86.79
S36-P1D-R04	231372.94	578587.94	86.79

TRASARE PILOTI PILA "P1"- fir dreapta				
Pct.	Y-(EST)	X-(NORD)	Zsup	Zinf
S36-P1D-P01	231369.68	578586.60	86.89	66.79
S36-P1D-P02	231371.52	578589.58	86.89	66.79
S36-P1D-P03	231372.45	578584.90	86.89	66.79
S36-P1D-P04	231374.28	578587.88	86.89	66.79
S36-P1D-P05	231375.21	578583.19	86.99	66.79
S36-P1D-P06	231377.05	578586.17	86.89	66.79
S36-P1D-P07	231377.98	578581.49	86.89	66.79
S36-P1D-P08	231379.82	578584.47	86.89	66.79
S36-P1D-P09	231380.75	578579.79	86.89	66.79
S36-P1D-P10	231382.58	578582.77	86.89	66.79

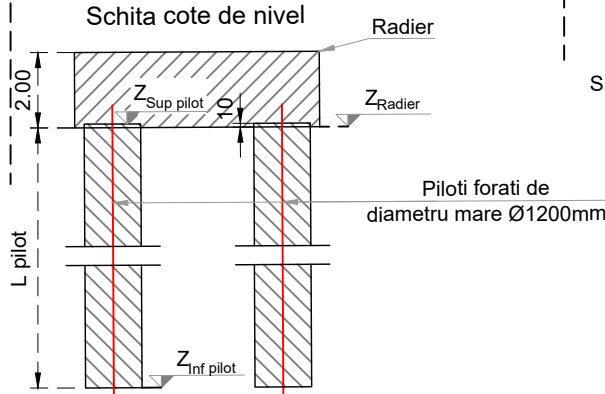
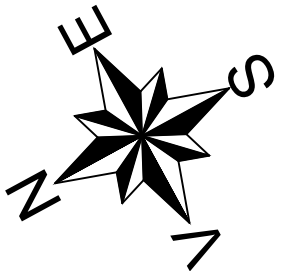

PROIECTANT / DESIGNER:  
S.C. CONSITRANS S.R.L.



BENEFICIAR / BENEFICIARY:  
MUNICIPIUL ARAD, MUNICIPIUL ORADEA, CONSILIUL JUDETEAN ARAD, CONSILIUL JUDETEAN BIHOR CNAIR

FUNCTIA / POSITION:  
NUME / NAME:  
SEMNATURA / SIGNATURE:

Titlu plansa / Drawing title:  
Plan trasare - plan 1/12  
Layout plan - plan 1/12

REV. / REV.	DATA / DATE:	DETALII REVIZIE / REVISION DETAILS:	PROIECTAT / DESIGNER:
R00	11.2023	P.T.E.	Consitrans

INVESTITIA / INVESTMENT:  
ACTUALIZARE/COMPLETARE/REVIZUIRE (S.F. + P.A.C. + P.O.E + P.T.E.) "DRUM EXPRES ARAD ORADEA"  
ACTUALIZATION/COMPLETION (S.F. + P.A.C. + P.O.E + P.T.E.) "EXPRESS ROAD ARAD ORADEA"

COORDONATOR DE PROIECT / PROJECT MANAGER: ing. S. VEACESLAV  
SEF PROIECT SPECIALITATE / TEAM LEADER: ing. D. COVELTIR

Pod pe DX la km 57+600 peste Crisul Negru  
Bridge on DX at km 57+600 over Crisul Negru river

LUCRARI DE POD / BRIDGE WORKS



PROIECT CO-FINANȚAT DIN FONDUL DE COEZIUNE, PRIN PROGRAMUL OPERAȚIONAL INFRASTRUCTURĂ MARE / PROJECT CO-FINANCED FROM THE COHESION FUND, THROUGH THE LARGE INFRASTRUCTURE OPERATIONAL PROGRAM

FAZA PROIECTARE / DESIGN STAGE:  
PROIECT TEHNIC DE EXECUTIE / EXECUTION TECHNICAL PROJECT  
Contract /Contract: 14724/01.07.2021  
Data /Date: 11.2023  
Scara /Scale: 1:200

PROIECTAT / DESIGNER: ing. V. URDAREANU  
VERIFICAT / INTERNAL CHECKER: ing. D. COVELTIR

Cod plansa / Drawing code:  
CST-0121-PTE-02-DX- 02-P36-PTR-01-R00

# P2

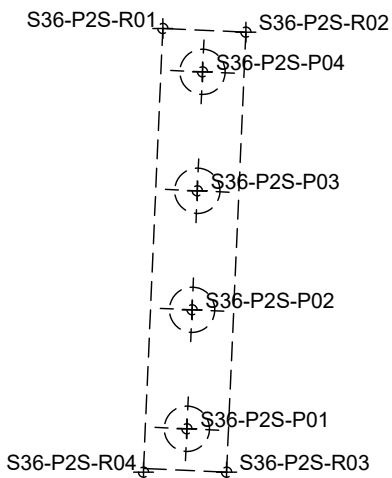
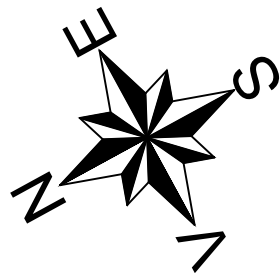

TRASARE RADIER PILA "P2"- fir stanga

Pct.	Y-(EST)	X-(NORD)	Z
S36-P2S-R01	231374.08	578538.64	87.54
S36-P2S-R02	231372.94	578536.76	87.54
S36-P2S-R03	231362.97	578542.78	87.54
S36-P2S-R04	231364.02	578544.71	87.54

TRASARE PILOTI PILA "P2"- fir stanga

Pct.	Y-(EST)	X-(NORD)	Zsup	Zinf
S36-P2S-P01	231364.48	578543.15	87.64	67.54
S36-P2S-P02	231367.18	578541.52	87.64	67.54
S36-P2S-P03	231369.87	578539.90	87.64	67.54
S36-P2S-P04	231372.57	578538.27	87.64	67.54

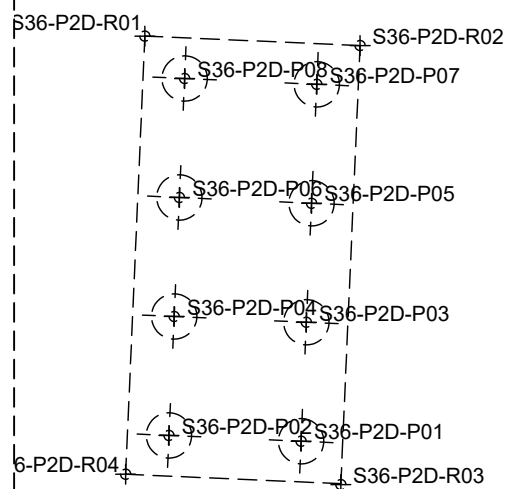

TRASARE RADIER PILA "P2"- fir dreapta

Pct.	Y-(EST)	X-(NORD)	Z
S36-P2D-R01	231361.24	578546.39	87.11
S36-P2D-R02	231360.10	578544.51	87.11
S36-P2D-R03	231350.13	578550.53	87.11
S36-P2D-R04	231351.27	578552.41	87.11

TRASARE PILOTI PILA "P2"- fir dreapta

Pct.	Y-(EST)	X-(NORD)	Zsup	Zinf
S36-P2D-P01	231350.73	578549.41	87.21	67.11
S36-P2D-P02	231352.54	578552.40	87.21	67.11
S36-P2D-P03	231353.43	578547.78	87.21	67.11
S36-P2D-P04	231355.24	578550.77	87.21	67.11
S36-P2D-P05	231356.13	578546.15	87.21	67.11
S36-P2D-P06	231357.94	578549.15	87.21	67.11
S36-P2D-P07	231358.82	578544.52	87.21	67.11
S36-P2D-P08	231360.63	578547.52	87.21	67.11

# P3

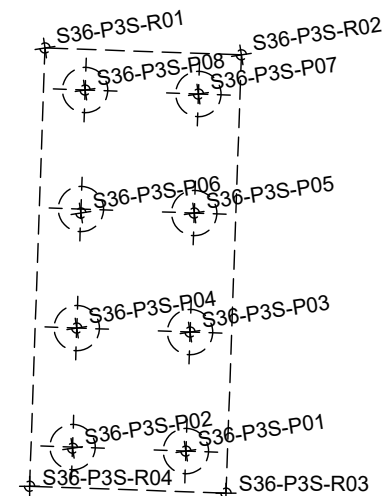

TRASARE RADIER PILA "P3"- fir stanga

Pct.	Y-(EST)	X-(NORD)	Z
S36-P3S-R01	231353.84	578504.86	86.55
S36-P3S-R02	231351.19	578500.38	86.55
S36-P3S-R03	231341.21	578506.29	86.55
S36-P3S-R04	231343.85	578510.77	86.55

TRASARE PILOTI PILA "P3"- fir stanga

Pct.	Y-(EST)	X-(NORD)	Zsup	Zinf
S36-P3S-P01	231342.69	578506.69	86.65	66.55
S36-P3S-P02	231344.19	578509.29	86.65	66.55
S36-P3S-P03	231345.40	578505.09	86.65	66.55
S36-P3S-P04	231346.93	578507.67	86.65	66.55
S36-P3S-P05	231348.11	578503.48	86.65	66.55
S36-P3S-P06	231349.55	578506.11	86.65	66.55
S36-P3S-P07	231350.82	578501.88	86.65	66.55
S36-P3S-P08	231352.35	578504.46	86.65	66.55

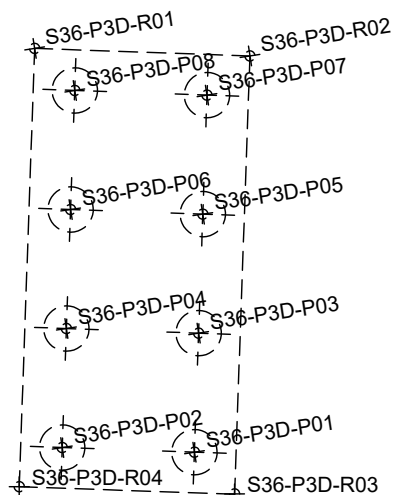

TRASARE RADIER PILA "P3"- fir dreapta

Pct.	Y-(EST)	X-(NORD)	Z
S36-P3D-R01	231340.93	578512.50	86.32
S36-P3D-R02	231338.28	578508.02	86.32
S36-P3D-R03	231328.30	578513.93	86.32
S36-P3D-R04	231330.95	578518.41	86.32

TRASARE PILOTI PILA "P3"- fir dreapta

Pct.	Y-(EST)	X-(NORD)	Zsup	Zinf
S36-P3D-P01	231329.78	578514.33	86.42	66.32
S36-P3D-P02	231331.31	578516.91	86.42	66.32
S36-P3D-P03	231332.49	578512.73	86.42	66.32
S36-P3D-P04	231334.02	578515.31	86.42	66.32
S36-P3D-P05	231335.20	578511.12	86.42	66.32
S36-P3D-P06	231336.73	578513.70	86.42	66.32
S36-P3D-P07	231337.91	578509.52	86.42	66.32
S36-P3D-P08	231339.44	578512.10	86.42	66.32

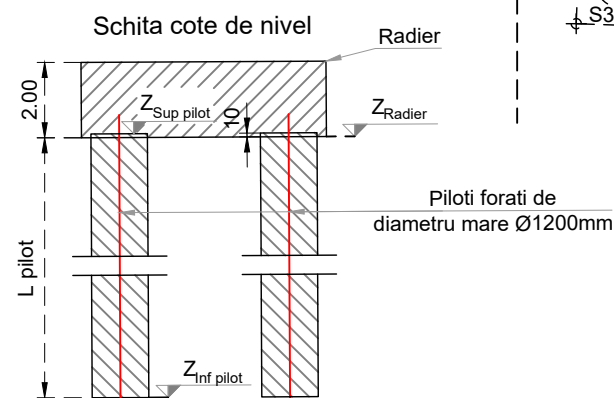

PROIECTANT / DESIGNER:  
S.C. CONSITRANS S.R.L.



BENEFICIAR / BENEFICIARY:  
MUNICIPIUL ARAD, MUNICIPIUL ORADEA, CONSILIUL JUDETEAN ARAD, CONSILIUL JUDETEAN BIHOR CNAIR

FUNCTIA / POSITION:  
COORDONATOR DE PROIECT / PROJECT MANAGER

NUME / NAME:  
ing. S. VEACESLAV

SEMNATURA / SIGNATURE:  
*[Signature]*

Titlu plansa / Drawing title:  
Plan trasare - plan 2/12  
Layout plan - plan 2/12

REV. / REV.:  
R00

DATA / DATE:  
11.2023

DETALII REVIZIE / REVISION DETAILS:  
P.T.E.

PROIECTAT / DESIGNER:  
Consitrans

INVESTITIA / INVESTMENT:  
ACTUALIZARE/COMPLETARE/REVIZUIRE (S.F. + P.A.C. + P.O.E + P.T.E.) "DRUM EXPRES ARAD ORADEA"  
ACTUALIZATION/COMPLETION (S.F. + P.A.C. + P.O.E + P.T.E.) "EXPRESS ROAD ARAD ORADEA"

SEF PROIECT SPECIALITATE / TEAM LEADER

ing. D. COVELTIR

*[Signature]*

Pod pe DX la km 57+600 peste Crisul Negru  
Bridge on DX at km 57+600 over Crisul Negru river

FAZA PROIECTARE / DESIGN STAGE:  
PROIECT TEHNIC DE EXECUTIE / EXECUTION TECHNICAL PROJECT

PROIECTAT / DESIGNER:

ing. V. URDAREANU

*[Signature]*

LUCRARI DE POD / BRIDGE WORKS

Contract /Contract: 14724/01.07.2021  
Data /Date: 11.2023  
Scara /Scale: 1:200

VERIFICAT / INTERNAL CHECKER:

ing. D. COVELTIR

*[Signature]*

Cod plansa / Drawing code:  
CST-0121-PTE-02-DX- 02-P36-PTR-02-R00



UNIUNEA EUROPEANA



GUVERNUL ROMANIEI



Instrumente Structurale 2014-2020

PROIECT CO-FINANAT DIN FONDUL DE COEZIUNE, PRIN PROGRAMUL OPERATIONAL INFRASTRUCTURA MARE / PROJECT CO-FINANCED FROM THE COHESION FUND, THROUGH THE LARGE INFRASTRUCTURE OPERATIONAL PROGRAM

# P4

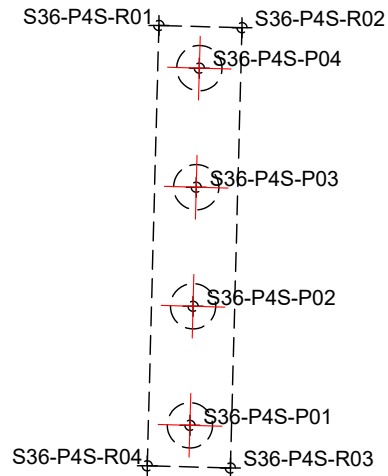
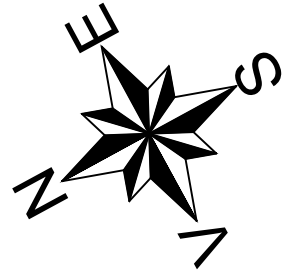

TRASARE RADIER PILA "P4"- fir stanga

Pct.	Y-(EST)	X-(NORD)	Z
S36-P4S-R01	231332.41	578468.29	86.92
S36-P4S-R02	231331.31	578466.38	86.92
S36-P4S-R03	231321.23	578472.23	86.92
S36-P4S-R04	231322.34	578474.13	86.92

TRASARE PILOTI PILA "P4"- fir stanga

Pct.	Y-(EST)	X-(NORD)	Zsup	Zinf
S36-P4S-P01	231322.74	578472.63	87.02	66.92
S36-P4S-P02	231325.46	578471.05	87.02	66.92
S36-P4S-P03	231328.19	578469.47	87.02	66.92
S36-P4S-P04	231330.91	578467.89	87.02	66.92

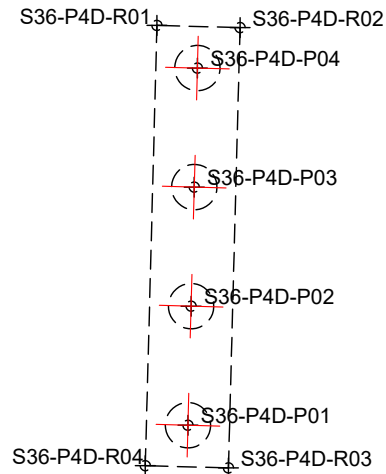

TRASARE RADIER PILA "P4"- fir dreapta

Pct.	Y-(EST)	X-(NORD)	Z
S36-P4D-R01	231319.44	578475.81	86.92
S36-P4D-R02	231318.34	578473.91	86.92
S36-P4D-R03	231308.26	578479.76	86.92
S36-P4D-R04	231309.36	578481.66	86.92

TRASARE PILOTI PILA "P4"- fir dreapta

Pct.	Y-(EST)	X-(NORD)	Zsup	Zinf
S36-P4D-P01	231309.76	578480.16	87.02	66.92
S36-P4D-P02	231312.49	578478.58	87.02	66.92
S36-P4D-P03	231315.21	578477.00	87.02	66.92
S36-P4D-P04	231317.94	578475.41	87.02	66.92

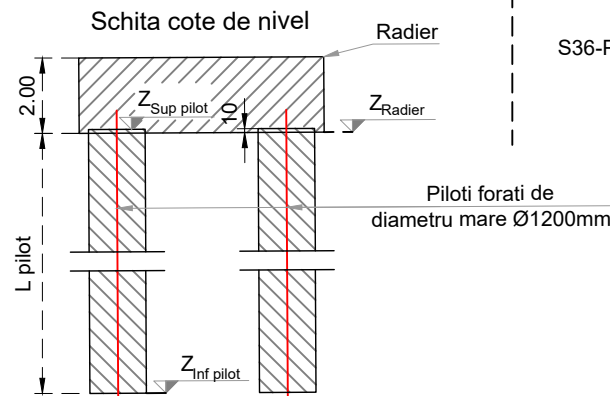

# P5

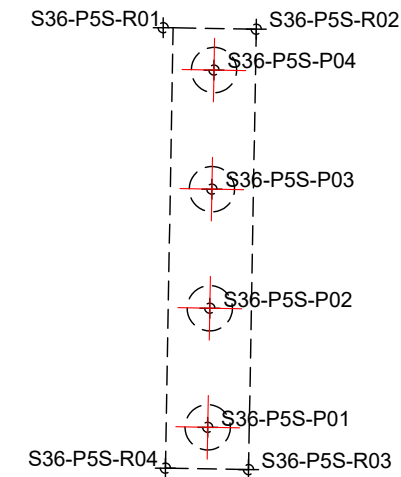

TRASARE RADIER PILA "P5"- fir stanga

Pct.	Y-(EST)	X-(NORD)	Z
S36-P5S-R01	231311.92	578432.64	87.00
S36-P5S-R02	231310.71	578430.49	87.00
S36-P5S-R03	231300.58	578436.25	87.00
S36-P5S-R04	231301.67	578438.16	87.00

TRASARE PILOTI PILA "P5"- fir stanga

Pct.	Y-(EST)	X-(NORD)	Zsup	Zinf
S36-P5S-P01	231302.08	578436.66	87.10	67.00
S36-P5S-P02	231304.82	578435.11	87.10	67.00
S36-P5S-P03	231307.56	578433.55	87.10	67.00
S36-P5S-P04	231310.30	578431.99	87.10	67.00

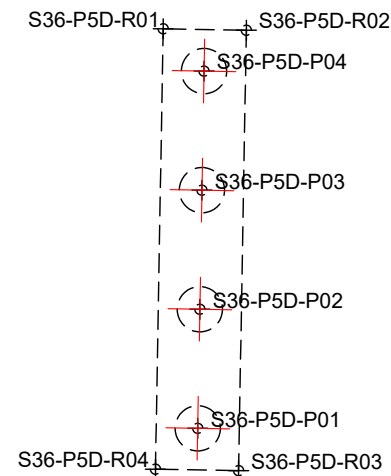

TRASARE RADIER PILA "P5"- fir dreapta

Pct.	Y-(EST)	X-(NORD)	Z
S36-P5D-R01	231298.76	578439.82	87.00
S36-P5D-R02	231297.67	578437.91	87.00
S36-P5D-R03	231287.54	578443.66	87.00
S36-P5D-R04	231288.63	578445.58	87.00

TRASARE PILOTI PILA "P5"- fir dreapta

Pct.	Y-(EST)	X-(NORD)	Zsup	Zinf
S36-P5D-P01	231289.04	578444.08	87.10	67.00
S36-P5D-P02	231291.78	578442.52	87.10	67.00
S36-P5D-P03	231294.52	578440.96	87.10	67.00
S36-P5D-P04	231297.26	578439.41	87.10	67.00

PROIECTANT / DESIGNER:  
S.C. CONSITRANS S.R.L.



BENEFICIAR / BENEFICIARY:  
MUNICIPIUL ARAD, MUNICIPIUL ORADEA, CONSILIUL JUDETEAN ARAD, CONSILIUL JUDETEAN BIHOR CNAIR

FUNCTIA / POSITION:  
COORDONATOR DE PROIECT / PROJECT MANAGER

NUME / NAME:  
ing. S. VEACESLAV

SEMNATURA / SIGNATURE:  
*[Signature]*

Titlu plansa / Drawing title:  
Plan trasare - plan 3/12  
Layout plan - plan 3/12

REV. / REV.:  
R00

DATA / DATE:  
11.2023

DETALII REVIZIE / REVISION DETAILS:  
P.T.E.

PROIECTAT / DESIGNER:  
Consitrans

INVESTITIA / INVESTMENT:  
ACTUALIZARE/COMPLETARE/REVIZUIRE (S.F. + P.A.C. + P.O.E + P.T.E.) "DRUM EXPRES ARAD ORADEA"  
ACTUALIZATION/COMPLETION (S.F. + P.A.C. + P.O.E + P.T.E.) "EXPRESS ROAD ARAD ORADEA"

SEF PROIECT SPECIALITATE / TEAM LEADER  
ing. D. COVELTIR

ing. D. COVELTIR

*[Signature]*

Pod pe DX la km 57+600 peste Crisul Negru  
Bridge on DX at km 57+600 over Crisul Negru river

LUCRARI DE POD / BRIDGE WORKS

Cod plansa / Drawing code:  
CST-0121-PTE-02-DX- 02-P36-PTR-03-R00



UNIUNEA EUROPEANA



GUVERNUL ROMANIEI



Instrumente Structurale 2014-2020

PROIECT CO-FINANAT DIN FONDUL DE COEZIUNE, PRIN PROGRAMUL OPERATIONAL INFRASTRUCTURA MARE / PROJECT CO-FINANCED FROM THE COHESION FUND, THROUGH THE LARGE INFRASTRUCTURE OPERATIONAL PROGRAM

FAZA PROIECTARE / DESIGN STAGE:  
PROIECT TEHNIC DE EXECUTIE / EXECUTION TECHNICAL PROJECT

PROIECTAT / DESIGNER:  
ing. V. URDAREANU

ing. V. URDAREANU

*[Signature]*

VERIFICAT / INTERNAL CHECKER:  
ing. D. COVELTIR

ing. D. COVELTIR

*[Signature]*

# P6

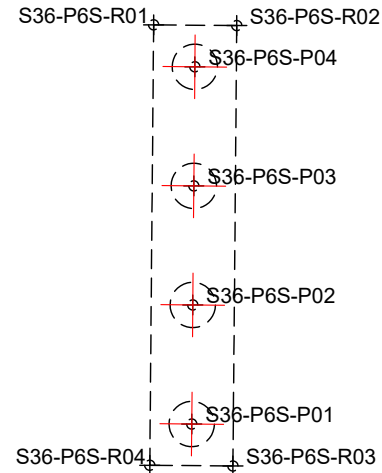
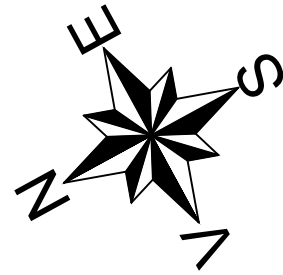

TRASARE RADIER PILA "P6"- fir stanga

Pct.	Y-(EST)	X-(NORD)	Z
S36-P6S-R01	231291.50	578396.34	87.20
S36-P6S-R02	231290.43	578394.42	87.20
S36-P6S-R03	231280.25	578400.09	87.20
S36-P6S-R04	231281.32	578402.01	87.20

TRASARE PILOTI PILA "P6"- fir stanga

Pct.	Y-(EST)	X-(NORD)	Zsup	Zinf
S36-P6S-P01	231281.74	578400.52	87.30	63.20
S36-P6S-P02	231284.50	578398.98	87.30	63.20
S36-P6S-P03	231287.25	578397.45	87.30	63.20
S36-P6S-P04	231290.00	578395.92	87.30	63.20

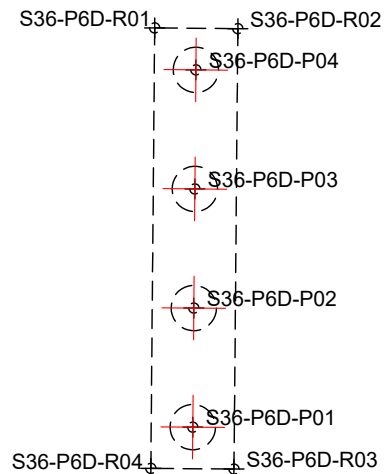

TRASARE RADIER PILA "P6"- fir dreapta

Pct.	Y-(EST)	X-(NORD)	Z
S36-P6D-R01	231278.39	578403.64	87.06
S36-P6D-R02	231277.32	578401.72	87.06
S36-P6D-R03	231267.14	578407.39	87.06
S36-P6D-R04	231268.21	578409.31	87.06

TRASARE PILOTI PILA "P6"- fir dreapta

Pct.	Y-(EST)	X-(NORD)	Zsup	Zinf
S36-P6D-P01	231268.64	578407.81	87.16	63.06
S36-P6D-P02	231271.39	578406.28	87.16	63.06
S36-P6D-P03	231274.14	578404.75	87.16	63.06
S36-P6D-P04	231276.90	578403.22	87.16	63.06

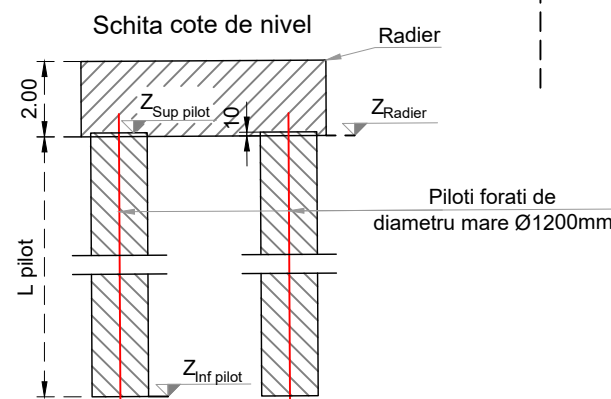

# P7

TRASARE RADIER PILA "P7"- fir stanga

Pct.	Y-(EST)	X-(NORD)	Z
S36-P7S-R01	231272.45	578361.87	87.21
S36-P7S-R02	231269.96	578357.31	87.21
S36-P7S-R03	231259.78	578362.86	87.21
S36-P7S-R04	231262.27	578367.43	87.21

TRASARE PILOTI PILA "P7"- fir stanga

Pct.	Y-(EST)	X-(NORD)	Zsup	Zinf
S36-P7S-P01	231261.25	578363.31	87.31	63.21
S36-P7S-P02	231262.68	578365.95	87.31	63.21
S36-P7S-P03	231264.01	578361.80	87.31	63.21
S36-P7S-P04	231265.45	578364.44	87.31	63.21
S36-P7S-P05	231266.78	578360.30	87.31	63.21
S36-P7S-P06	231268.22	578362.93	87.31	63.21
S36-P7S-P07	231269.54	578358.79	87.31	63.21
S36-P7S-P08	231270.98	578361.42	87.31	63.21

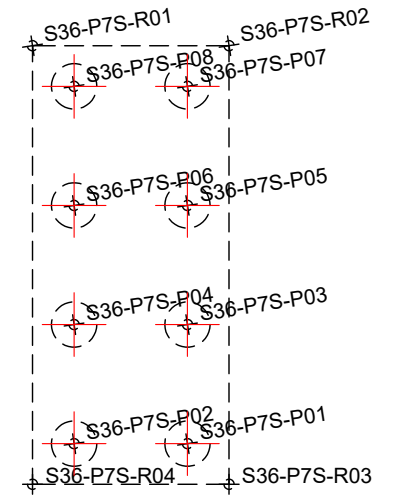

TRASARE RADIER PILA "P7"- fir dreapta

Pct.	Y-(EST)	X-(NORD)	Z
S36-P7D-R01	231259.28	578369.05	87.21
S36-P7D-R02	231256.79	578364.49	87.21
S36-P7D-R03	231246.61	578370.04	87.21
S36-P7D-R04	231249.10	578374.61	87.21

TRASARE PILOTI PILA "P7"- fir dreapta

Pct.	Y-(EST)	X-(NORD)	Zsup	Zinf
S36-P7D-P01	231248.08	578370.50	87.31	63.21
S36-P7D-P02	231249.52	578373.13	87.31	63.21
S36-P7D-P03	231250.85	578368.99	87.31	63.21
S36-P7D-P04	231252.28	578371.62	87.31	63.21
S36-P7D-P05	231253.61	578367.48	87.31	63.21
S36-P7D-P06	231255.05	578370.11	87.31	63.21
S36-P7D-P07	231256.38	578365.97	87.31	63.21
S36-P7D-P08	231257.81	578368.60	87.31	63.21

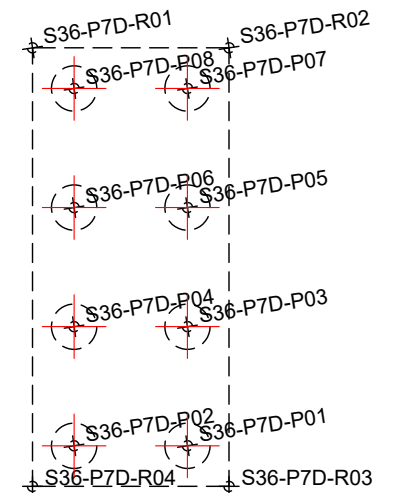

PROIECTANT / DESIGNER:  
S.C. CONSTRANS S.R.L.



BENEFICIAR / BENEFICIARY:  
MUNICIPIUL ARAD, MUNICIPIUL ORADEA, CONSILIUL JUDETEAN ARAD, CONSILIUL JUDETEAN BIHOR CNAIR

FUNCTIA / POSITION:  
COORDONATOR DE PROIECT / PROJECT MANAGER

NUME / NAME:  
ing. S. VEACESLAV

SEMNTATURA / SIGNATURE:  
*[Signature]*

Titlu plansa / Drawing title:  
Plan trasare - plan 4/12  
Layout plan - plan 4/12

REV / REV.:  
R00

DATA / DATE:  
11.2023

DETALII REVIZIE / REVISION DETAILS:  
P.T.E.

PROIECTAT / DESIGNER:  
Constrans

INVESTITIA / INVESTMENT:  
ACTUALIZARE/COMPLETARE/REVIZUIRE (S.F. + P.A.C. + P.O.E + P.T.E.) "DRUM EXPRES ARAD ORADEA"  
ACTUALIZATION/COMPLETION (S.F. + P.A.C. + P.O.E + P.T.E.) "EXPRESS ROAD ARAD ORADEA"

SEF PROIECT SPECIALITATE / TEAM LEADER

ing. D. COVELTIR

*[Signature]*

Pod pe DX la km 57+600 peste Crisul Negru  
Bridge on DX at km 57+600 over Crisul Negru river

LUCRARI DE POD / BRIDGE WORKS

Cod plansa / Drawing code:  
CST-0121-PTE-02-DX- 02-P36-PTR-04-R00



UNIUNEA EUROPEANA



GUVERNUL ROMANIEI



Instrumente Structurale 2014-2020

PROIECT CO-FINANAT DIN FONDUL DE COEZIUNE, PRIN PROGRAMUL OPERATIONAL INFRASTRUCTURA MARE / PROJECT CO-FINANCED FROM THE COHESION FUND, THROUGH THE LARGE INFRASTRUCTURE OPERATIONAL PROGRAM

FAZA PROIECTARE / DESIGN STAGE:  
PROIECT TEHNIC DE EXECUTIE / EXECUTION TECHNICAL PROJECT

PROIECTAT / DESIGNER:  
VERIFICAT / INTERNAL CHECKER:

ing. V. URDAREANU  
ing. D. COVELTIR

*[Signature]*  
*[Signature]*

Contract /Contract:  
14724/01.07.2021  
Data /Date:  
11.2023  
Scara /Scale:  
1:200

# P8

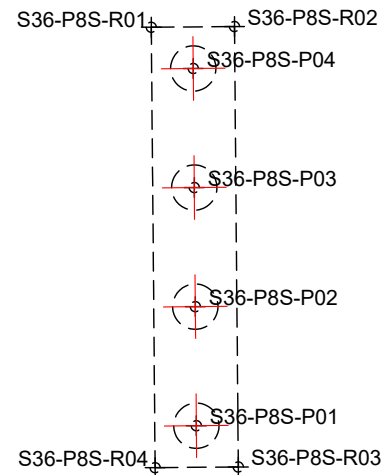
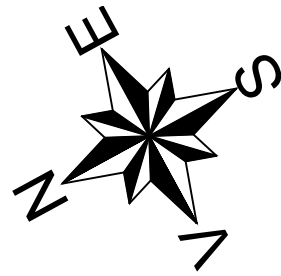

TRASARE RADIER PILA "P8"- fir stanga				
Pct.	Y-(EST)	X-(NORD)	Z	
S36-P8S-R01	231252.33	578324.57	87.27	
S36-P8S-R02	231251.29	578322.63	87.27	
S36-P8S-R03	231241.01	578328.12	87.27	
S36-P8S-R04	231242.05	578330.06	87.27	
TRASARE PILOTI PILA "P8"- fir stanga				
Pct.	Y-(EST)	X-(NORD)	Zsup	Zinf
S36-P8S-P01	231242.50	578328.57	87.37	63.27
S36-P8S-P02	231245.28	578327.09	87.37	63.27
S36-P8S-P03	231248.06	578325.60	87.37	63.27
S36-P8S-P04	231250.84	578324.12	87.37	63.27

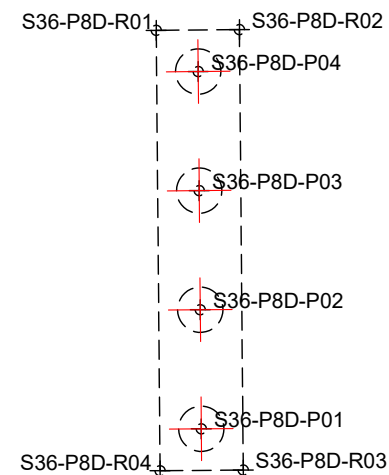

TRASARE RADIER PILA "P8"- fir dreapta				
Pct.	Y-(EST)	X-(NORD)	Z	
S36-P8D-R01	231239.10	578331.64	87.27	
S36-P8D-R02	231238.06	578329.70	87.27	
S36-P8D-R03	231227.78	578335.19	87.27	
S36-P8D-R04	231228.82	578337.13	87.27	
TRASARE PILOTI PILA "P8"- fir dreapta				
Pct.	Y-(EST)	X-(NORD)	Zsup	Zinf
S36-P8D-P01	231229.27	578335.64	87.37	63.27
S36-P8D-P02	231232.05	578334.16	87.37	63.27
S36-P8D-P03	231234.83	578332.67	87.37	63.27
S36-P8D-P04	231237.61	578331.19	87.37	63.27

# P9

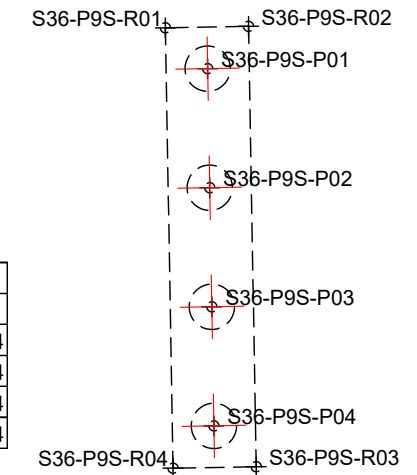

TRASARE RADIER PILA "P9"- fir stanga				
Pct.	Y-(EST)	X-(NORD)	Z	
S36-P9S-R01	231232.98	578287.99	88.04	
S36-P9S-R02	231231.96	578286.04	88.04	
S36-P9S-R03	231221.64	578291.44	88.04	
S36-P9S-R04	231222.66	578293.39	88.04	
TRASARE PILOTI PILA "P9"- fir stanga				
Pct.	Y-(EST)	X-(NORD)	Zsup	Zinf
S36-P9S-P01	231231.50	578287.52	88.14	63.04
S36-P9S-P02	231228.70	578288.98	88.14	63.04
S36-P9S-P03	231225.91	578290.44	88.14	63.04
S36-P9S-P04	231223.12	578291.90	88.14	63.04

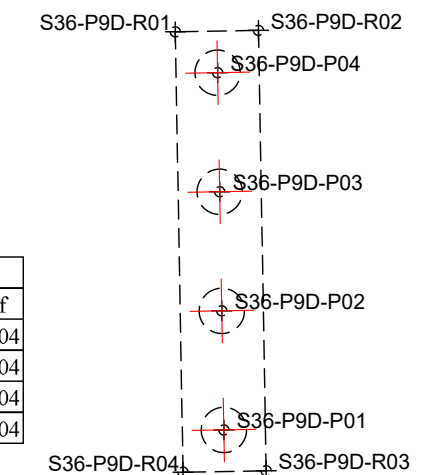

TRASARE RADIER PILA "P9"- fir dreapta				
Pct.	Y-(EST)	X-(NORD)	Z	
S36-P9D-R01	231219.69	578294.94	88.04	
S36-P9D-R02	231218.67	578292.99	88.04	
S36-P9D-R03	231208.34	578298.39	88.04	
S36-P9D-R04	231209.36	578300.34	88.04	
TRASARE PILOTI PILA "P9"- fir dreapta				
Pct.	Y-(EST)	X-(NORD)	Zsup	Zinf
S36-P9D-P01	231209.83	578298.85	88.14	63.04
S36-P9D-P02	231212.62	578297.39	88.14	63.04
S36-P9D-P03	231215.41	578295.93	88.14	63.04
S36-P9D-P04	231218.20	578294.47	88.14	63.04

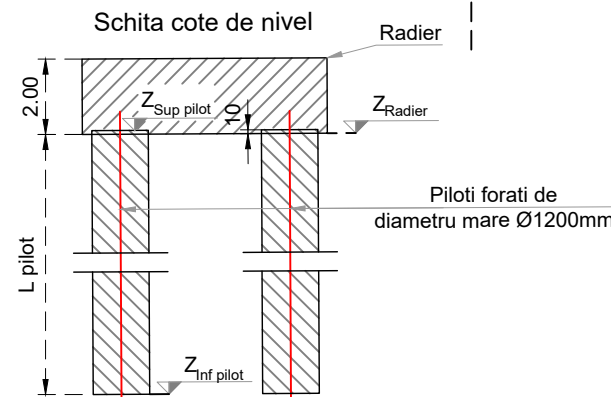

<b>PROIECTANT / DESIGNER:</b> S.C. CONSITRANS S.R.L.		<b>BENEFICIAR / BENEFICIARY:</b> MUNICIPIUL ARAD, MUNICIPIUL ORADEA, CONSILIUL JUDETEAN ARAD, CONSILIUL JUDETEAN BIHOR CNAIR		<b>FUNCTIA / POSITION:</b> COORDONATOR DE PROIECT / PROJECT MANAGER	<b>NUME / NAME:</b> ing. S. VEACESLAV	<b>SEMNATURA / SIGNATURE:</b> 	<b>Titlu plansa / Drawing title:</b> Plan trasare - plan 5/12 Layout plan - plan 5/12	<b>REV. / REV.:</b> R00	<b>DATA / DATE:</b> 11.2023	<b>DETALII REVIZIE / REVISION DETAILS:</b> P.T.E.	<b>PROIECTAT / DESIGNER:</b> Consitrans
		<b>INVESTITIA / INVESTMENT:</b> ACTUALIZARE/COMPLETARE/REVIZUIRE (S.F. + P.A.C. + P.O.E + P.T.E.) "DRUM EXPRES ARAD ORADEA" ACTUALIZATION/COMPLETION (S.F. + P.A.C. + P.O.E + P.T.E.) "EXPRESS ROAD ARAD ORADEA"		<b>SEF PROIECT SPECIALITATE / TEAM LEADER:</b> ing. D. COVELTIR				Pod pe DX la km 57+600 peste Crisul Negru Bridge on DX at km 57+600 over Crisul Negru river			
				<b>FAZA PROIECTARE / DESIGN STAGE:</b> PROIECT TEHNIC DE EXECUTIE / EXECUTION TECHNICAL PROJECT		<b>PROIECTAT / DESIGNER:</b> ing. V. URDAREANU		<b>LUCRARI DE POD / BRIDGE WORKS</b>			
Instrumente Structurale 2014-2020		Contract /Contract: 14724/01.07.2021 Data / Date: 11.2023 Scara /Scale: 1:200		<b>VERIFICAT / INTERNAL CHECKER:</b> ing. D. COVELTIR		<b>Cod plansa / Drawing code:</b> CST-0121-PTE-02-DX- 02-P36-PTR-05-R00					

# P10

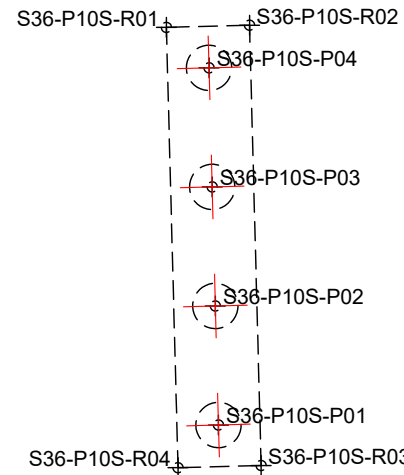
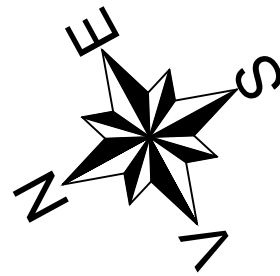

TRASARE RADIER PILA "P10"- fir stanga			
Pct.	Y-(EST)	X-(NORD)	Z
S36-P10S-R01	231213.96	578251.24	88.24
S36-P10S-R02	231212.96	578249.28	88.24
S36-P10S-R03	231202.59	578254.59	88.24
S36-P10S-R04	231203.59	578256.54	88.24

TRASARE PILOTI PILA "P10"- fir stanga				
Pct.	Y-(EST)	X-(NORD)	Zsup	Zinf
S36-P10S-P01	231204.07	578255.06	88.34	63.24
S36-P10S-P02	231206.87	578253.63	88.34	63.24
S36-P10S-P03	231209.67	578252.19	88.34	63.24
S36-P10S-P04	231212.48	578250.76	88.34	63.24

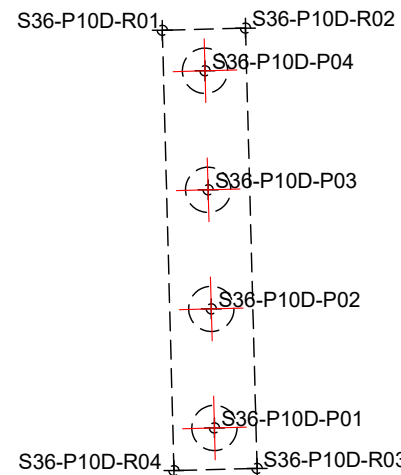

TRASARE RADIER PILA "P10"- fir dreapta			
Pct.	Y-(EST)	X-(NORD)	Z
S36-P10D-R01	231200.61	578258.07	88.24
S36-P10D-R02	231199.60	578256.11	88.24
S36-P10D-R03	231189.23	578261.42	88.24
S36-P10D-R04	231190.23	578263.38	88.24

TRASARE PILOTI PILA "P10"- fir dreapta				
Pct.	Y-(EST)	X-(NORD)	Zsup	Zinf
S36-P10D-P01	231190.71	578261.90	88.34	63.24
S36-P10D-P02	231193.52	578260.46	88.34	63.24
S36-P10D-P03	231196.32	578259.03	88.34	63.24
S36-P10D-P04	231199.13	578257.59	88.34	63.24

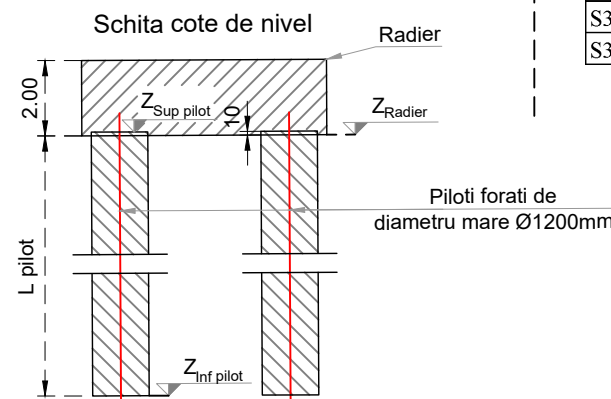

# P11

TRASARE RADIER PILA "P11"- fir stanga			
Pct.	Y-(EST)	X-(NORD)	Z
S36-P11S-R01	231196.25	578216.34	87.93
S36-P11S-R02	231193.69	578211.25	87.93
S36-P11S-R03	231183.32	578216.44	87.93
S36-P11S-R04	231185.87	578221.54	87.93

TRASARE PILOTI PILA "P11"- fir stanga				
Pct.	Y-(EST)	X-(NORD)	Zsup	Zinf
S36-P11S-P01	231184.78	578216.94	88.03	67.93
S36-P11S-P02	231186.34	578220.07	88.03	67.93
S36-P11S-P03	231187.59	578215.53	88.03	67.93
S36-P11S-P04	231189.16	578218.66	88.03	67.93
S36-P11S-P05	231190.41	578214.12	88.03	67.93
S36-P11S-P06	231191.98	578217.25	88.03	67.93
S36-P11S-P07	231193.23	578212.71	88.03	67.93
S36-P11S-P08	231194.79	578215.84	88.03	67.93

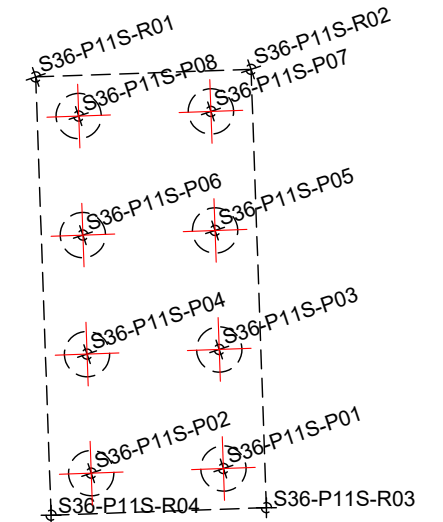

TRASARE RADIER PILA "P11"- fir dreapta			
Pct.	Y-(EST)	X-(NORD)	Z
S36-P11D-R01	231182.83	578223.06	87.93
S36-P11D-R02	231180.28	578217.96	87.93
S36-P11D-R03	231169.91	578223.16	87.93
S36-P11D-R04	231172.46	578228.25	87.93

  

TRASARE PILOTI PILA "P11"- fir dreapta				
Pct.	Y-(EST)	X-(NORD)	Zsup	Zinf
S36-P11D-P01	231171.36	578223.66	88.03	67.93
S36-P11D-P02	231172.93	578226.79	88.03	67.93
S36-P11D-P03	231174.18	578222.25	88.03	67.93
S36-P11D-P04	231175.75	578225.38	88.03	67.93
S36-P11D-P05	231177.00	578220.84	88.03	67.93
S36-P11D-P06	231178.56	578223.97	88.03	67.93
S36-P11D-P07	231179.81	578219.43	88.03	67.93
S36-P11D-P08	231181.38	578222.56	88.03	67.93

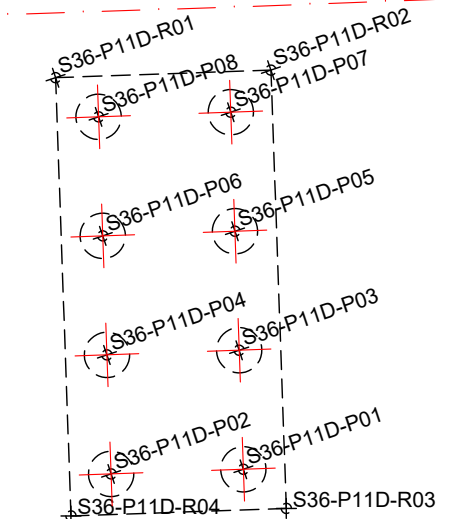

<b>PROIECTANT / DESIGNER:</b> S.C. CONSITRANS S.R.L.		<b>BENEFICIAR / BENEFICIARY:</b> MUNICIPIUL ARAD, MUNICIPIUL ORADEA, CONSILIUL JUDETEAN ARAD, CONSILIUL JUDETEAN BIHOR CNAIR		<b>FUNCTIA / POSITION:</b> COORDONATOR DE PROIECT / PROJECT MANAGER	<b>NUME / NAME:</b> ing. S. VEACESLAV	<b>SEMNATURA / SIGNATURE:</b> 	<b>Titlu plansa / Drawing title:</b> Plan trasare - plan 6/12 Layout plan - plan 6/12	<b>REV. / REV.:</b> R00	<b>DATA / DATE:</b> 11.2023	<b>DETALII REVIZIE / REVISION DETAILS:</b> P.T.E.	<b>PROIECTAT / DESIGNER:</b> Consitrans
		<b>INVESTITIA / INVESTMENT:</b> ACTUALIZARE/COMPLETARE/REVIZUIRE (S.F. + P.A.C. + P.O.E + P.T.E.) "DRUM EXPRES ARAD ORADEA" ACTUALIZATION/COMPLETION (S.F. + P.A.C. + P.O.E + P.T.E.) "EXPRESS ROAD ARAD ORADEA"		<b>SEF PROIECT SPECIALITATE / TEAM LEADER:</b> ing. D. COVELTIR				Pod pe DX la km 57+600 peste Crisul Negru Bridge on DX at km 57+600 over Crisul Negru river			
		<b>FAZA PROIECTARE / DESIGN STAGE:</b> PROIECT TEHNIC DE EXECUTIE / EXECUTION TECHNICAL PROJECT		<b>PROIECTAT / DESIGNER:</b> ing. V. URDAREANU		<b>LUCRARI DE POD / BRIDGE WORKS</b>	<b>Cod plansa / Drawing code:</b> CST-0121-PTE-02-DX- 02-P36-PTR-06-R00				
UNIUNEA EUROPEANA PROIECT CO-FINANAT DIN FONDUL DE COEZIUNE, PRIN PROGRAMUL OPERATIONAL INFRASTRUCTURA MARE / PROJECT CO-FINANCED FROM THE COHESION FUND, THROUGH THE LARGE INFRASTRUCTURE OPERATIONAL PROGRAM		Contract /Contract: 14724/01.07.2021	Data /Date: 11.2023	Scara /Scale: 1:200	<b>VERIFICAT / INTERNAL CHECKER:</b> ing. D. COVELTIR						

# P12

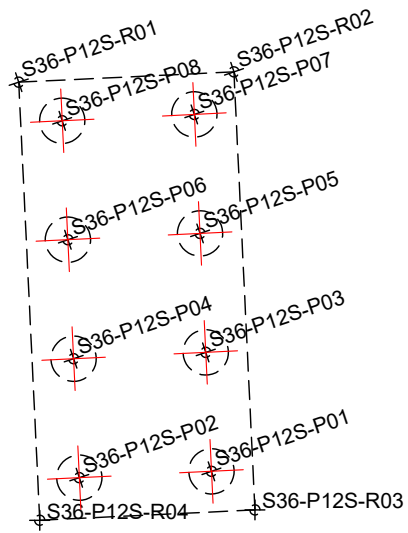

TRASARE RADIER PILA "P12" - fir stanga				
Pct.	Y-(EST)	X-(NORD)	Z	
S36-P12S-R01	231169.66	578162.47	87.46	
S36-P12S-R02	231167.17	578157.34	87.46	
S36-P12S-R03	231156.73	578162.40	87.46	
S36-P12S-R04	231159.22	578167.53	87.46	
TRASARE PILOTI PILA "P12" - fir stanga				
Pct.	Y-(EST)	X-(NORD)	Zsup	Zinf
S36-P12S-P01	231158.18	578162.92	87.56	67.46
S36-P12S-P02	231159.71	578166.07	87.56	67.46
S36-P12S-P03	231161.02	578161.54	87.56	67.46
S36-P12S-P04	231162.54	578164.69	87.56	67.46
S36-P12S-P05	231163.85	578160.17	87.56	67.46
S36-P12S-P06	231165.38	578163.32	87.56	67.46
S36-P12S-P07	231166.68	578158.80	87.56	67.46
S36-P12S-P08	231168.21	578161.95	87.56	67.46

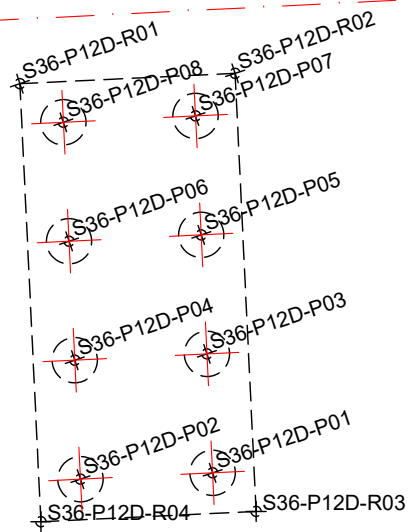

TRASARE RADIER PILA "P12" - fir dreapta				
Pct.	Y-(EST)	X-(NORD)	Z	
S36-P12D-R01	231156.16	578169.01	87.46	
S36-P12D-R02	231153.67	578163.88	87.46	
S36-P12D-R03	231143.24	578168.94	87.46	
S36-P12D-R04	231145.72	578174.07	87.46	
TRASARE PILOTI PILA "P12" - fir dreapta				
Pct.	Y-(EST)	X-(NORD)	Zsup	Zinf
S36-P12D-P01	231144.68	578169.46	87.56	67.46
S36-P12D-P02	231146.21	578172.61	87.56	67.46
S36-P12D-P03	231147.52	578168.09	87.56	67.46
S36-P12D-P04	231149.05	578171.24	87.56	67.46
S36-P12D-P05	231150.35	578166.71	87.56	67.46
S36-P12D-P06	231151.88	578169.86	87.56	67.46
S36-P12D-P07	231153.19	578165.34	87.56	67.46
S36-P12D-P08	231154.71	578168.49	87.56	67.46

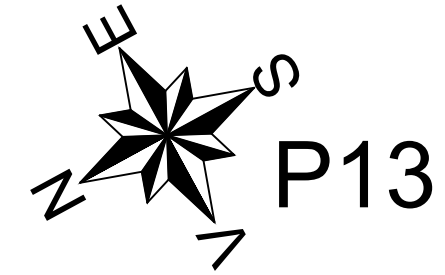
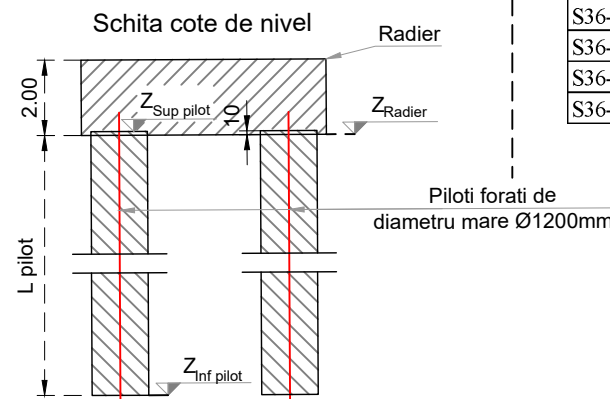

# P13

TRASARE RADIER PILA "P13" - fir stanga				
Pct.	Y-(EST)	X-(NORD)	Z	
S36-P13S-R01	231135.43	578090.41	87.74	
S36-P13S-R02	231133.03	578085.24	87.74	
S36-P13S-R03	231122.51	578090.12	87.74	
S36-P13S-R04	231124.90	578095.29	87.74	
TRASARE PILOTI PILA "P13" - fir stanga				
Pct.	Y-(EST)	X-(NORD)	Zsup	Zinf
S36-P13S-P01	231123.94	578090.67	87.84	59.74
S36-P13S-P02	231125.42	578093.84	87.84	59.74
S36-P13S-P03	231126.80	578089.34	87.84	59.74
S36-P13S-P04	231128.27	578092.52	87.84	59.74
S36-P13S-P05	231129.66	578088.02	87.84	59.74
S36-P13S-P06	231131.13	578091.19	87.84	59.74
S36-P13S-P07	231132.52	578086.69	87.84	59.74
S36-P13S-P08	231133.99	578089.87	87.84	59.74

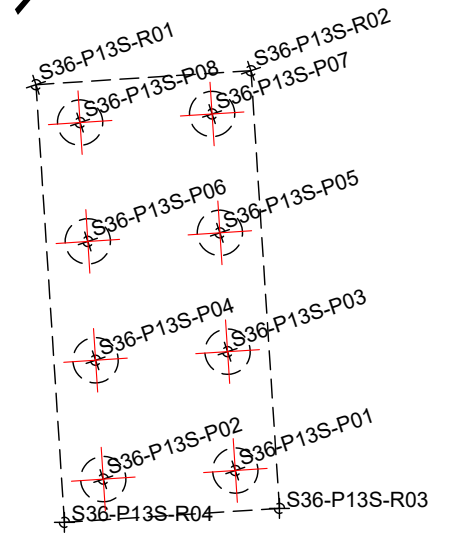

TRASARE RADIER PILA "P13" - fir dreapta				
Pct.	Y-(EST)	X-(NORD)	Z	
S36-P13D-R01	231121.82	578096.72	87.74	
S36-P13D-R02	231119.42	578091.55	87.74	
S36-P13D-R03	231108.90	578096.44	87.74	
S36-P13D-R04	231111.30	578101.61	87.74	
TRASARE PILOTI PILA "P13" - fir dreapta				
Pct.	Y-(EST)	X-(NORD)	Zsup	Zinf
S36-P13D-P01	231110.34	578096.98	87.84	59.74
S36-P13D-P02	231111.81	578100.16	87.84	59.74
S36-P13D-P03	231113.19	578095.66	87.84	59.74
S36-P13D-P04	231114.67	578098.83	87.84	59.74
S36-P13D-P05	231116.05	578094.33	87.84	59.74
S36-P13D-P06	231117.52	578097.51	87.84	59.74
S36-P13D-P07	231118.91	578093.00	87.84	59.74
S36-P13D-P08	231120.38	578096.18	87.84	59.74

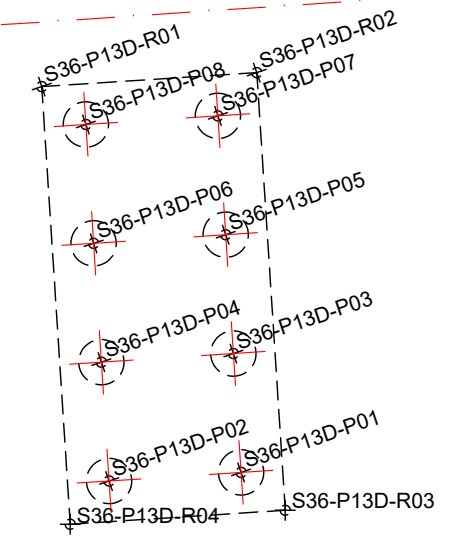

PROIECTANT / DESIGNER:  
S.C. CONSITRANS S.R.L.



BENEFICIAR / BENEFICIARY:  
MUNICIPIUL ARAD, MUNICIPIUL ORADEA, CONSILIUL JUDETEAN ARAD, CONSILIUL JUDETEAN BIHOR CNAIR

FUNCTIA / POSITION:  
COORDONATOR DE PROIECT / PROJECT MANAGER

NUME / NAME:  
ing. S. VEACESLAV

SEMNATURA / SIGNATURE:  
*[Signature]*

Titlu plansa / Drawing title:  
Plan trasare - plan 7/12  
Layout plan - plan 7/12

REV/ REV.:  
R00

DATA/ DATE:  
11.2023

DETALII REVIZIE / REVISION DETAILS:  
P.T.E.

PROIECTAT / DESIGNER:  
Consitrans

INVESTITIA / INVESTMENT:  
ACTUALIZARE/COMPLETARE/REVIZUIRE (S.F. + P.A.C. + P.O.E + P.T.E.) "DRUM EXPRES ARAD ORADEA"  
ACTUALIZATION/COMPLETION (S.F. + P.A.C. + P.O.E + P.T.E.) "EXPRESS ROAD ARAD ORADEA"

SEF PROIECT SPECIALITATE / TEAM LEADER  
ing. D. COVELTIR

SEMNATURA / SIGNATURE:  
*[Signature]*

Pod pe DX la km 57+600 peste Crisul Negru  
Bridge on DX at km 57+600 over Crisul Negru river

REV/ REV.:  
R00

DATA/ DATE:  
11.2023

DETALII REVIZIE / REVISION DETAILS:  
P.T.E.

PROIECTAT / DESIGNER:  
Consitrans



UNIUNEA EUROPEANA



GUVERNUL ROMANIEI



Instrumente Structurale 2014-2020

PROIECT CO-FINANȚAT DIN FONDUL DE COEZIUNE, PRIN PROGRAMUL OPERAȚIONAL INFRASTRUCTURĂ MARE / PROJECT CO-FINANCED FROM THE COHESION FUND, THROUGH THE LARGE INFRASTRUCTURE OPERATIONAL PROGRAM

FAZA PROIECTARE / DESIGN STAGE:  
PROIECT TEHNIC DE EXECUTIE / EXECUTION TECHNICAL PROJECT

PROIECTAT / DESIGNER:  
ing. V. URDAREANU

SEMNATURA / SIGNATURE:  
*[Signature]*

LUCRARI DE POD / BRIDGE WORKS

REV/ REV.:  
R00

DATA/ DATE:  
11.2023

DETALII REVIZIE / REVISION DETAILS:  
P.T.E.

PROIECTAT / DESIGNER:  
Consitrans

Contract /Contract: 14724/01.07.2021  
Data /Date: 11.2023  
Scara /Scale: 1:200

VERIFICAT / INTERNAL CHECKER:  
ing. D. COVELTIR

SEMNATURA / SIGNATURE:  
*[Signature]*

Cod plansa / Drawing code:  
CST-0121-PTE-02-DX- 02-P36-PTR-07-R00

# P14

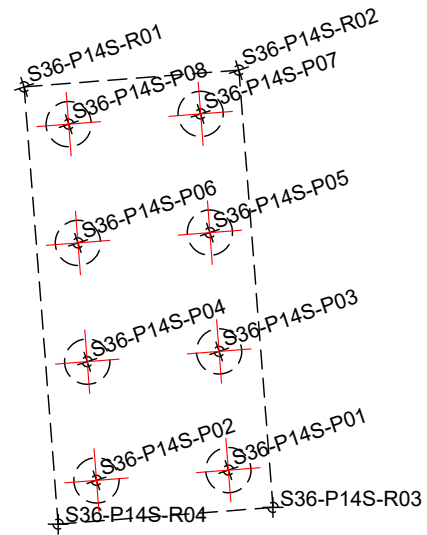

TRASARE RADIER PILA "P14"- fir stanga				
Pct.	Y-(EST)	X-(NORD)	Z	
S36-P14S-R01	231110.46	578035.77	87.89	
S36-P14S-R02	231108.13	578030.57	87.89	
S36-P14S-R03	231097.54	578035.31	87.89	
S36-P14S-R04	231099.87	578040.51	87.89	
TRASARE PILOTI PILA "P14"- fir stanga				
Pct.	Y-(EST)	X-(NORD)	Zsup	Zinf
S36-P14S-P01	231098.97	578035.88	87.99	63.89
S36-P14S-P02	231100.40	578039.07	87.99	63.89
S36-P14S-P03	231101.85	578034.59	87.99	63.89
S36-P14S-P04	231103.28	578037.78	87.99	63.89
S36-P14S-P05	231104.72	578033.30	87.99	63.89
S36-P14S-P06	231106.15	578036.49	87.99	63.89
S36-P14S-P07	231107.60	578032.01	87.99	63.89
S36-P14S-P08	231109.03	578035.20	87.99	63.89

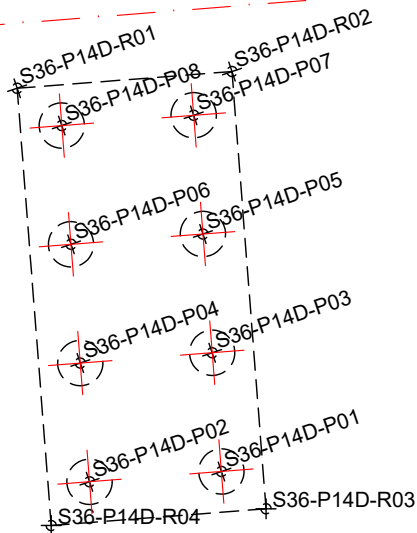

TRASARE RADIER PILA "P14"- fir dreapta				
Pct.	Y-(EST)	X-(NORD)	Z	
S36-P14D-R01	231096.77	578041.90	87.89	
S36-P14D-R02	231094.44	578036.70	87.89	
S36-P14D-R03	231083.85	578041.45	87.89	
S36-P14D-R04	231086.19	578046.65	87.89	
TRASARE PILOTI PILA "P14"- fir dreapta				
Pct.	Y-(EST)	X-(NORD)	Zsup	Zinf
S36-P14D-P01	231085.29	578042.01	87.99	63.89
S36-P14D-P02	231086.72	578045.21	87.99	63.89
S36-P14D-P03	231088.16	578040.73	87.99	63.89
S36-P14D-P04	231089.59	578043.92	87.99	63.89
S36-P14D-P05	231091.03	578039.44	87.99	63.89
S36-P14D-P06	231092.47	578042.63	87.99	63.89
S36-P14D-P07	231093.91	578038.15	87.99	63.89
S36-P14D-P08	231095.34	578041.34	87.99	63.89

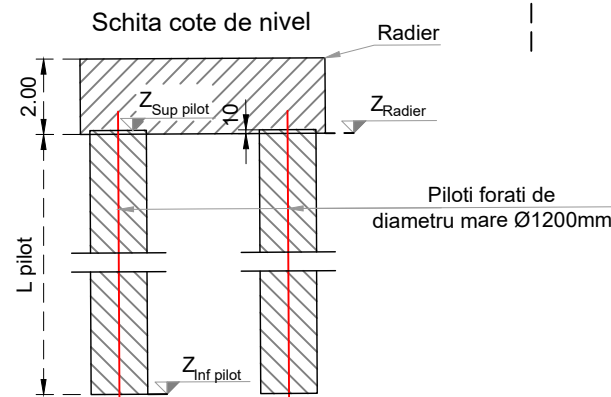

# P15

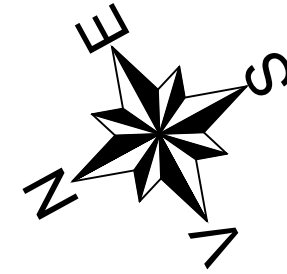

TRASARE RADIER PILA "P15"- fir stanga				
Pct.	Y-(EST)	X-(NORD)	Z	
S36-P15S-R01	231093.19	577996.79	87.47	
S36-P15S-R02	231092.31	577994.77	87.47	
S36-P15S-R03	231081.64	577999.45	87.47	
S36-P15S-R04	231082.52	578001.46	87.47	
TRASARE PILOTI PILA "P15"- fir stanga				
Pct.	Y-(EST)	X-(NORD)	Zsup	Zinf
S36-P15S-P01	231083.08	578000.01	87.57	67.47
S36-P15S-P02	231085.97	577998.75	87.57	67.47
S36-P15S-P03	231088.86	577997.48	87.57	67.47
S36-P15S-P04	231091.74	577996.22	87.57	67.47

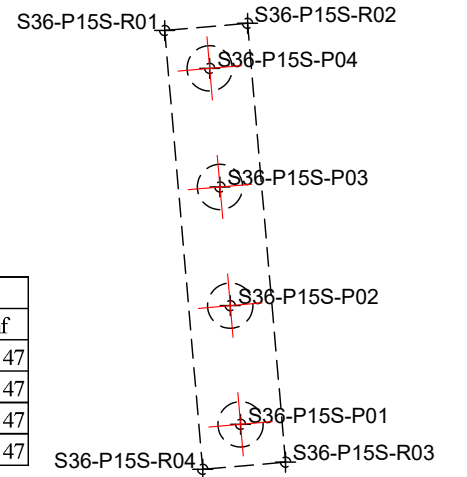

TRASARE RADIER PILA "P15"- fir dreapta				
Pct.	Y-(EST)	X-(NORD)	Z	
S36-P15D-R01	231079.45	578002.81	87.47	
S36-P15D-R02	231078.57	578000.79	87.47	
S36-P15D-R03	231067.90	578005.46	87.47	
S36-P15D-R04	231068.78	578007.48	87.47	
TRASARE PILOTI PILA "P15"- fir dreapta				
Pct.	Y-(EST)	X-(NORD)	Zsup	Zinf
S36-P15D-P01	231069.34	578006.03	87.57	67.47
S36-P15D-P02	231072.23	578004.77	87.57	67.47
S36-P15D-P03	231075.12	578003.50	87.57	67.47
S36-P15D-P04	231078.00	578002.24	87.57	67.47

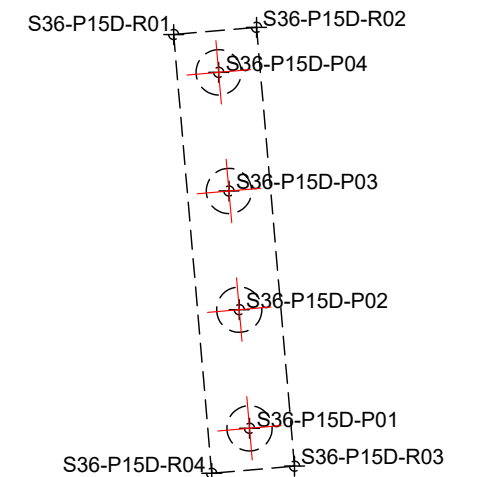

PROIECTANT / DESIGNER:  
S.C. CONSITRANS S.R.L.



BENEFICIAR / BENEFICIARY:  
MUNICIPIUL ARAD, MUNICIPIUL ORADEA, CONSILIUL JUDETEAN ARAD, CONSILIUL JUDETEAN BIHOR CNAIR

FUNCTIA / POSITION:  
COORDONATOR DE PROIECT / PROJECT MANAGER

NUME / NAME:  
ing. S. VEACESLAV

SEMNATURA / SIGNATURE:  
*[Signature]*

Titlu plansa / Drawing title:

Plan trasare - plan 8/12  
Layout plan - plan 8/12

REV/ REV. DATA/ DATE: R00 11.2023

DETALII REVIZIE / REVISION DETAILS: P.T.E.

PROIECTAT / DESIGNER: Consitrans

INVESTITIA / INVESTMENT:  
ACTUALIZARE/COMPLETARE/REVIZUIRE (S.F. + P.A.C. + P.O.E + P.T.E.) "DRUM EXPRES ARAD ORADEA"  
ACTUALIZATION/COMPLETION (S.F. + P.A.C. + P.O.E + P.T.E.) "EXPRESS ROAD ARAD ORADEA"

SEF PROIECT SPECIALITATE / TEAM LEADER  
ing. D. COVELTIR

SEMNATURA / SIGNATURE:  
*[Signature]*

Pod pe DX la km 57+600 peste Crisul Negru  
Bridge on DX at km 57+600 over Crisul Negru river

REV/ REV. DATA/ DATE:

DETALII REVIZIE / REVISION DETAILS:

PROIECTAT / DESIGNER:



UNIUNEA EUROPEANA



GUVERNUL ROMANIEI



Instrumente Structurale 2014-2020

PROIECT CO-FINANAT DIN FONDUL DE COEZIUNE, PRIN PROGRAMUL OPERATIONAL INFRASTRUCTURA MARE / PROJECT CO-FINANCED FROM THE COHESION FUND, THROUGH THE LARGE INFRASTRUCTURE OPERATIONAL PROGRAM

FAZA PROIECTARE / DESIGN STAGE:  
PROIECT TEHNIC DE EXECUTIE / EXECUTION TECHNICAL PROJECT

PROIECTAT / DESIGNER:  
ing. V. URDAREANU

SEMNATURA / SIGNATURE:  
*[Signature]*

LUCRARI DE POD / BRIDGE WORKS

REV/ REV. DATA/ DATE:

DETALII REVIZIE / REVISION DETAILS:

PROIECTAT / DESIGNER:

Contract /Contract: 14724/01.07.2021  
Data / Date: 11.2023  
Scara /Scale: 1:200

VERIFICAT / INTERNAL CHECKER:  
ing. D. COVELTIR

SEMNATURA / SIGNATURE:  
*[Signature]*

Cod plansa / Drawing code:  
CST-0121-PTE-02-DX- 02-P36-PTR-08-R00

REV/ REV. DATA/ DATE:

DETALII REVIZIE / REVISION DETAILS:

PROIECTAT / DESIGNER:



# P16

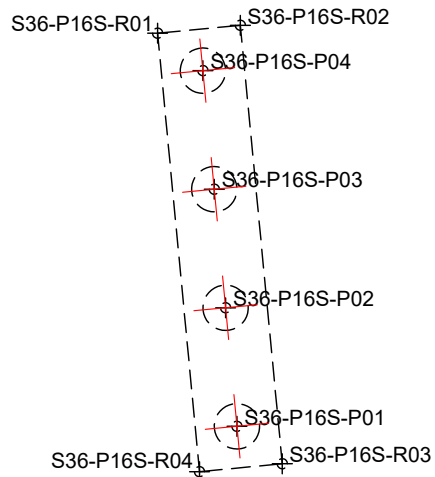
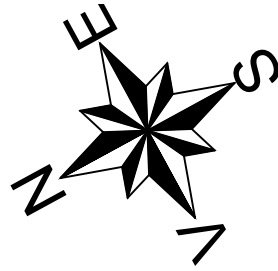

TRASARE RADIER PILA "P16"- fir stanga				
Pct.	Y-(EST)	X-(NORD)	Z	
S36-P16S-R01	231076.74	577958.81	87.06	
S36-P16S-R02	231075.88	577956.79	87.06	
S36-P16S-R03	231065.17	577961.37	87.06	
S36-P16S-R04	231066.03	577963.39	87.06	
TRASARE PILOTI PILA "P16"- fir stanga				
Pct.	Y-(EST)	X-(NORD)	Zsup	Zinf
S36-P16S-P01	231066.61	577961.95	87.16	67.06
S36-P16S-P02	231069.51	577960.71	87.16	67.06
S36-P16S-P03	231072.40	577959.47	87.16	67.06
S36-P16S-P04	231075.30	577958.23	87.16	67.06

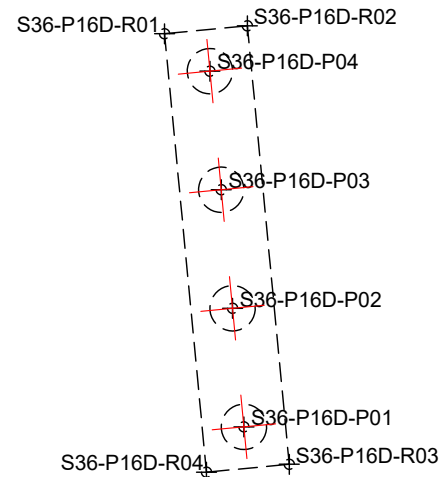

TRASARE RADIER PILA "P16"- fir dreapta				
Pct.	Y-(EST)	X-(NORD)	Z	
S36-P16D-R01	231062.95	577964.71	87.06	
S36-P16D-R02	231062.09	577962.69	87.06	
S36-P16D-R03	231051.38	577967.27	87.06	
S36-P16D-R04	231052.24	577969.29	87.06	
TRASARE PILOTI PILA "P16"- fir dreapta				
Pct.	Y-(EST)	X-(NORD)	Zsup	Zinf
S36-P16D-P01	231052.82	577967.85	87.16	67.06
S36-P16D-P02	231055.72	577966.61	87.16	67.06
S36-P16D-P03	231058.61	577965.37	87.16	67.06
S36-P16D-P04	231061.51	577964.13	87.16	67.06

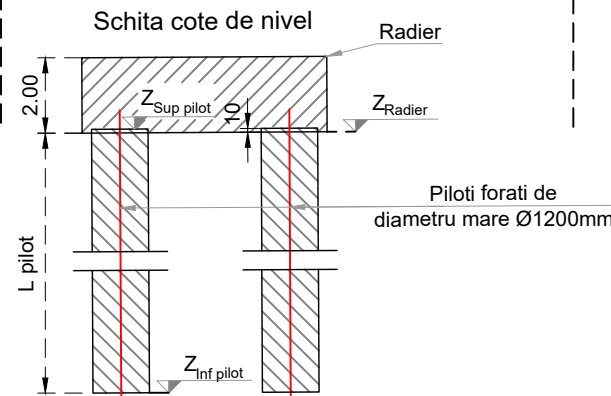

# P17

TRASARE RADIER PILA "P17"- fir stanga				
Pct.	Y-(EST)	X-(NORD)	Z	
S36-P17S-R01	231061.38	577922.55	87.35	
S36-P17S-R02	231059.38	577917.75	87.35	
S36-P17S-R03	231048.67	577922.22	87.35	
S36-P17S-R04	231050.68	577927.02	87.35	
TRASARE PILOTI PILA "P17"- fir stanga				
Pct.	Y-(EST)	X-(NORD)	Zsup	Zinf
S36-P17S-P01	231050.09	577922.82	87.45	63.35
S36-P17S-P02	231051.24	577925.59	87.45	63.35
S36-P17S-P03	231053.00	577921.61	87.45	63.35
S36-P17S-P04	231054.15	577924.37	87.45	63.35
S36-P17S-P05	231055.90	577920.39	87.45	63.35
S36-P17S-P06	231057.06	577923.16	87.45	63.35
S36-P17S-P07	231058.81	577919.18	87.45	63.35
S36-P17S-P08	231059.97	577921.95	87.45	63.35

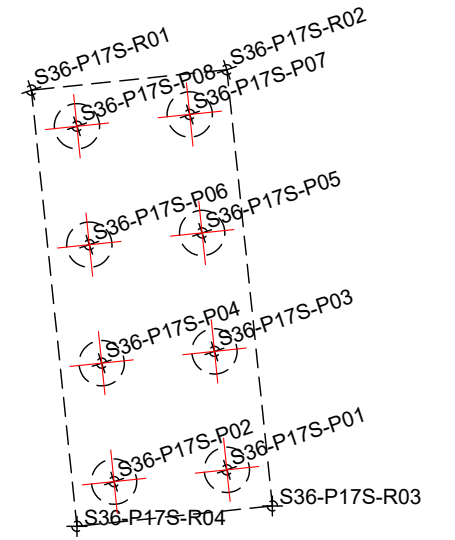

TRASARE RADIER PILA "P17"- fir dreapta				
Pct.	Y-(EST)	X-(NORD)	Z	
S36-P17D-R01	231047.54	577928.33	87.35	
S36-P17D-R02	231045.54	577923.53	87.35	
S36-P17D-R03	231034.83	577927.99	87.35	
S36-P17D-R04	231036.83	577932.79	87.35	
TRASARE PILOTI PILA "P17"- fir dreapta				
Pct.	Y-(EST)	X-(NORD)	Zsup	Zinf
S36-P17D-P01	231036.25	577928.59	87.45	63.35
S36-P17D-P02	231037.40	577931.36	87.45	63.35
S36-P17D-P03	231039.15	577927.38	87.45	63.35
S36-P17D-P04	231040.31	577930.15	87.45	63.35
S36-P17D-P05	231042.06	577926.17	87.45	63.35
S36-P17D-P06	231043.22	577928.94	87.45	63.35
S36-P17D-P07	231044.97	577924.96	87.45	63.35
S36-P17D-P08	231046.12	577927.72	87.45	63.35

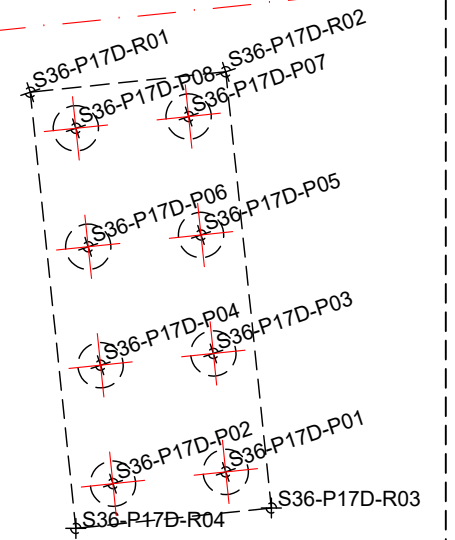

PROIECTANT / DESIGNER:  
S.C. CONSITRANS S.R.L.



BENEFICIAR / BENEFICIARY:  
MUNICIPIUL ARAD, MUNICIPIUL ORADEA, CONSILIUL JUDETEAN ARAD, CONSILIUL JUDETEAN BIHOR CNAIR

FUNCTIA / POSITION:  
COORDONATOR DE PROIECT / PROJECT MANAGER

NUME / NAME:  
ing. S. VEACESLAV

SEMNETURA / SIGNATURE:  
*[Signature]*

Titlu plansa / Drawing title:  
Plan trasare - plan 9/12  
Layout plan - plan 9/12

REV. / REV.:  
R00

DATA / DATE:  
11.2023

DETALII REVIZIE / REVISION DETAILS:  
P.T.E.

PROIECTAT / DESIGNER:  
Consitrans

INVESTITIA / INVESTMENT:  
ACTUALIZARE/COMPLETARE/REVIZUIRE (S.F. + P.A.C. + P.O.E + P.T.E.) "DRUM EXPRES ARAD ORADEA"  
ACTUALIZATION/COMPLETION (S.F. + P.A.C. + P.O.E + P.T.E.) "EXPRESS ROAD ARAD ORADEA"

SEF PROIECT SPECIALITATE / TEAM LEADER  
ing. D. COVELTIR

SEMNETURA / SIGNATURE:  
*[Signature]*

Pod pe DX la km 57+600 peste Crisul Negru  
Bridge on DX at km 57+600 over Crisul Negru river

REV. / REV.:  
R00

DATA / DATE:  
11.2023

DETALII REVIZIE / REVISION DETAILS:  
P.T.E.

PROIECTAT / DESIGNER:  
Consitrans



UNIUNEA EUROPEANA



GUVERNUL ROMANIEI



Instrumente Structurale 2014-2020

PROIECT CO-FINANȚAT DIN FONDUL DE COEZIUNE, PRIN PROGRAMUL OPERAȚIONAL INFRASTRUCTURĂ MARE / PROJECT CO-FINANCED FROM THE COHESION FUND, THROUGH THE LARGE INFRASTRUCTURE OPERATIONAL PROGRAM

FAZA PROIECTARE / DESIGN STAGE:  
PROIECT TEHNIC DE EXECUTIE / EXECUTION TECHNICAL PROJECT

PROIECTAT / DESIGNER:  
ing. V. URDAREANU

SEMNETURA / SIGNATURE:  
*[Signature]*

Cod plansa / Drawing code:  
CST-0121-PTE-02-DX- 02-P36-PTR-09-R00

REV. / REV.:  
R00

DATA / DATE:  
11.2023

DETALII REVIZIE / REVISION DETAILS:  
P.T.E.

PROIECTAT / DESIGNER:  
Consitrans

Contract /Contract: 14724/01.07.2021  
Data /Date: 11.2023  
Scara /Scale: 1:200

VERIFICAT / INTERNAL CHECKER:  
ing. D. COVELTIR

SEMNETURA / SIGNATURE:  
*[Signature]*

# P18

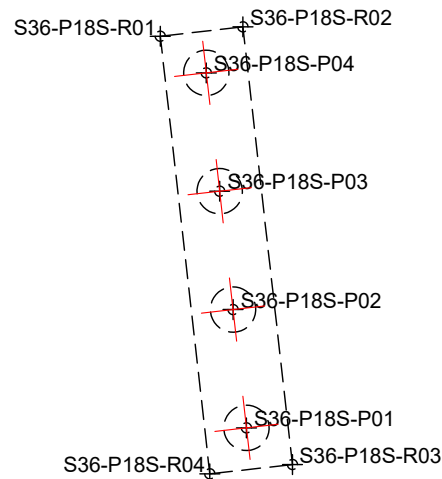

TRASARE RADIER PILA "P18" - fir stanga				
Pct.	Y-(EST)	X-(NORD)	Z	
S36-P18S-R01	231045.24	577883.36	87.50	
S36-P18S-R02	231044.41	577881.32	87.50	
S36-P18S-R03	231033.62	577885.71	87.50	
S36-P18S-R04	231034.45	577887.75	87.50	
TRASARE PILOTI PILA "P18" - fir stanga				
Pct.	Y-(EST)	X-(NORD)	Zsup	Zinf
S36-P18S-P01	231035.05	577886.32	87.60	63.50
S36-P18S-P02	231037.97	577885.13	87.60	63.50
S36-P18S-P03	231040.89	577883.94	87.60	63.50
S36-P18S-P04	231043.81	577882.76	87.60	63.50

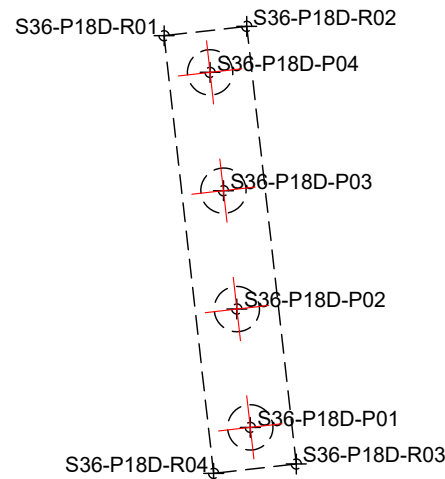

TRASARE RADIER PILA "P18" - fir dreapta				
Pct.	Y-(EST)	X-(NORD)	Z	
S36-P18D-R01	231031.35	577889.01	87.50	
S36-P18D-R02	231030.52	577886.98	87.50	
S36-P18D-R03	231019.73	577891.37	87.50	
S36-P18D-R04	231020.56	577893.41	87.50	
TRASARE PILOTI PILA "P18" - fir dreapta				
Pct.	Y-(EST)	X-(NORD)	Zsup	Zinf
S36-P18D-P01	231021.16	577891.97	87.60	63.50
S36-P18D-P02	231024.08	577890.79	87.60	63.50
S36-P18D-P03	231027.00	577889.60	87.60	63.50
S36-P18D-P04	231029.91	577888.41	87.60	63.50

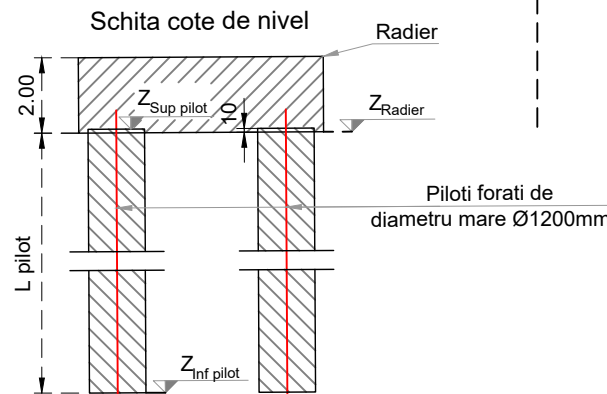

# P19

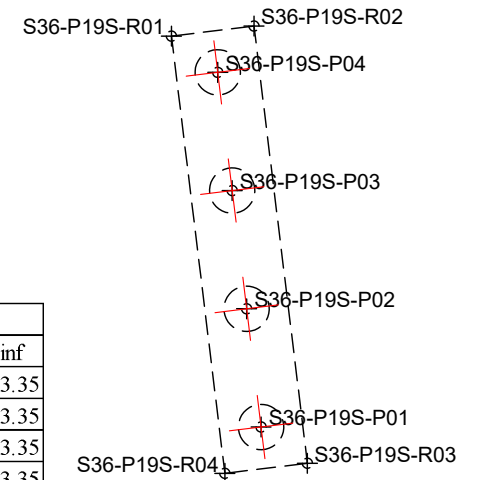
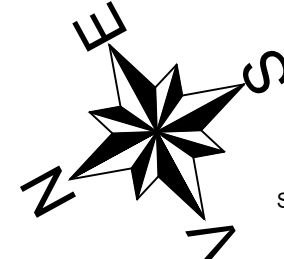

TRASARE RADIER PILA "P19" - fir stanga				
Pct.	Y-(EST)	X-(NORD)	Z	
S36-P19S-R01	231029.80	577844.97	87.35	
S36-P19S-R02	231028.99	577842.92	87.35	
S36-P19S-R03	231018.16	577847.22	87.35	
S36-P19S-R04	231018.97	577849.26	87.35	
TRASARE PILOTI PILA "P19" - fir stanga				
Pct.	Y-(EST)	X-(NORD)	Zsup	Zinf
S36-P19S-P01	231019.59	577847.84	87.45	63.35
S36-P19S-P02	231022.51	577846.67	87.45	63.35
S36-P19S-P03	231025.44	577845.51	87.45	63.35
S36-P19S-P04	231028.37	577844.35	87.45	63.35

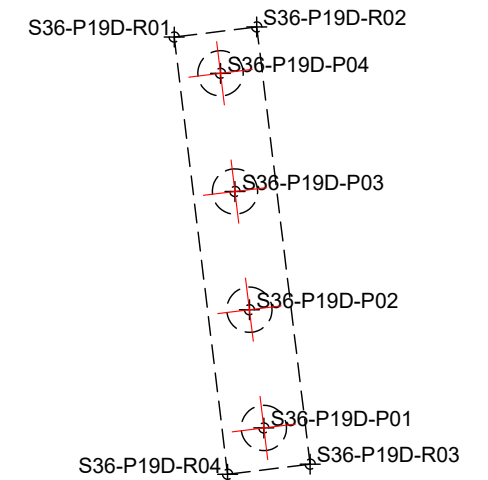

TRASARE RADIER PILA "P19" - fir dreapta				
Pct.	Y-(EST)	X-(NORD)	Z	
S36-P19D-R01	231015.86	577850.50	87.35	
S36-P19D-R02	231015.04	577848.45	87.35	
S36-P19D-R03	231004.22	577852.75	87.35	
S36-P19D-R04	231005.03	577854.80	87.35	
TRASARE PILOTI PILA "P19" - fir dreapta				
Pct.	Y-(EST)	X-(NORD)	Zsup	Zinf
S36-P19D-P01	231005.64	577853.37	87.45	63.35
S36-P19D-P02	231008.57	577852.21	87.45	63.35
S36-P19D-P03	231011.50	577851.04	87.45	63.35
S36-P19D-P04	231014.43	577849.88	87.45	63.35

PROIECTANT / DESIGNER:  
S.C. CONSTRANS S.R.L.



BENEFICIAR / BENEFICIARY:  
MUNICIPIUL ARAD, MUNICIPIUL ORADEA, CONSILIUL JUDETEAN ARAD, CONSILIUL JUDETEAN BIHOR CNAIR

FUNCTIA / POSITION:  
COORDONATOR DE PROIECT / PROJECT MANAGER

NUME / NAME:  
ing. S. VEACESLAV

SEMNATURA / SIGNATURE:  
*[Signature]*

Titlu plansa / Drawing title:  
Plan trasare - plan 10/12  
Layout plan - plan 10/12

REV. / REV.:  
R00

DATA / DATE:  
11.2023

DETALII REVIZIE / REVISION DETAILS:  
P.T.E.

PROIECTAT / DESIGNER:  
Constrans

INVESTITIA / INVESTMENT:  
ACTUALIZARE/COMPLETARE/REVIZUIRE (S.F. + P.A.C. + P.O.E + P.T.E.) "DRUM EXPRES ARAD ORADEA"  
ACTUALIZATION/COMPLETION (S.F. + P.A.C. + P.O.E + P.T.E.) "EXPRESS ROAD ARAD ORADEA"

SEF PROIECT SPECIALITATE / TEAM LEADER

ing. D. COVELTIR

*[Signature]*

Pod pe DX la km 57+600 peste Crisul Negru  
Bridge on DX at km 57+600 over Crisul Negru river

FAZA PROIECTARE / DESIGN STAGE:  
PROIECT TEHNIC DE EXECUTIE / EXECUTION TECHNICAL PROJECT

PROIECTAT / DESIGNER:

ing. V. URDAREANU

*[Signature]*

LUCRARI DE POD / BRIDGE WORKS

Contract / Contract: 14724/01.07.2021  
Data / Date: 11.2023  
Scara / Scale: 1:200

VERIFICAT / INTERNAL CHECKER:

ing. D. COVELTIR

*[Signature]*

Cod plansa / Drawing code:  
CST-0121-PTE-02-DX- 02-P36-PTR-10-R00



UNIUNEA EUROPEANA



GUVERNUL ROMANIEI



Instrumente Structurale 2014-2020

PROIECT CO-FINANAT DIN FONDUL DE COEZIUNE, PRIN PROGRAMUL OPERATIONAL INFRASTRUCTURA MARE / PROJECT CO-FINANCED FROM THE COHESION FUND, THROUGH THE LARGE INFRASTRUCTURE OPERATIONAL PROGRAM

# P20

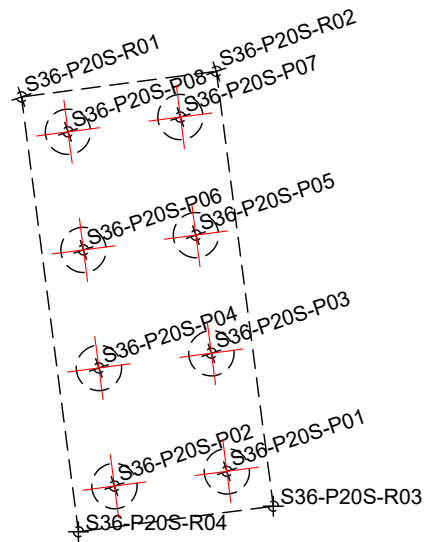

TRASARE RADIER PILA "P20"- fir stanga				
Pct.	Y-(EST)	X-(NORD)	Z	
S36-P20S-R01	231015.39	577808.31	87.41	
S36-P20S-R02	231013.52	577803.46	87.41	
S36-P20S-R03	231002.70	577807.65	87.41	
S36-P20S-R04	231004.57	577812.50	87.41	
TRASARE PILOTI PILA "P20"- fir stanga				
Pct.	Y-(EST)	X-(NORD)	Zsup	Zinf
S36-P20S-P01	231004.10	577808.28	87.51	63.41
S36-P20S-P02	231005.18	577811.08	87.51	63.41
S36-P20S-P03	231007.04	577807.15	87.51	63.41
S36-P20S-P04	231008.12	577809.95	87.51	63.41
S36-P20S-P05	231009.97	577806.01	87.51	63.41
S36-P20S-P06	231011.06	577808.81	87.51	63.41
S36-P20S-P07	231012.91	577804.87	87.51	63.41
S36-P20S-P08	231013.99	577807.67	87.51	63.41

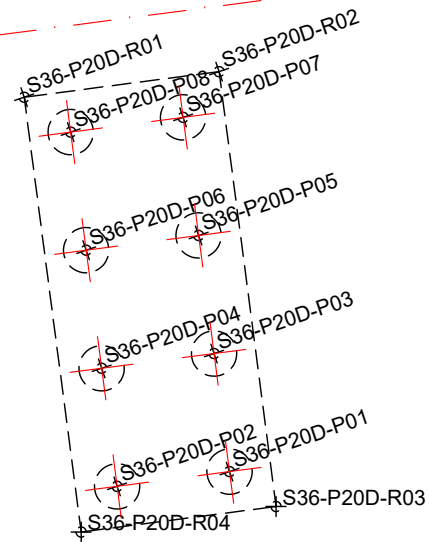

TRASARE RADIER PILA "P20"- fir dreapta				
Pct.	Y-(EST)	X-(NORD)	Z	
S36-P20D-R01	231001.40	577813.72	87.41	
S36-P20D-R02	230999.53	577808.87	87.41	
S36-P20D-R03	230988.71	577813.06	87.41	
S36-P20D-R04	230990.58	577817.91	87.41	
TRASARE PILOTI PILA "P20"- fir dreapta				
Pct.	Y-(EST)	X-(NORD)	Zsup	Zinf
S36-P20D-P01	230990.11	577813.69	87.51	63.41
S36-P20D-P02	230991.19	577816.49	87.51	63.41
S36-P20D-P03	230993.05	577812.56	87.51	63.41
S36-P20D-P04	230994.13	577815.36	87.51	63.41
S36-P20D-P05	230995.98	577811.42	87.51	63.41
S36-P20D-P06	230997.07	577814.22	87.51	63.41
S36-P20D-P07	230998.92	577810.29	87.51	63.41
S36-P20D-P08	231000.00	577813.08	87.51	63.41

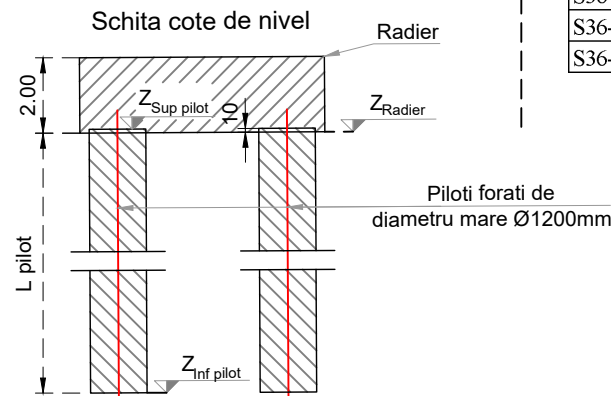

# P21

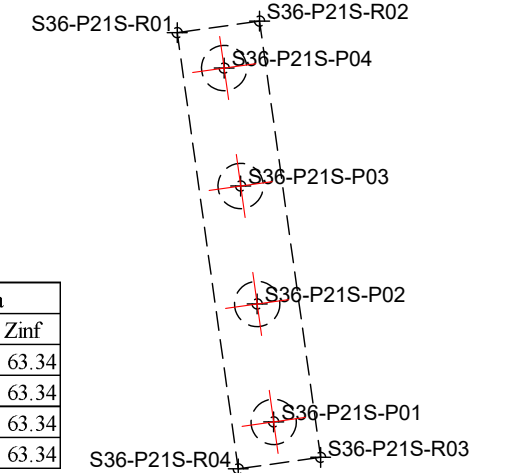
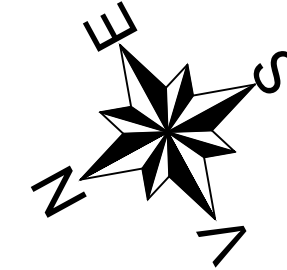

TRASARE RADIER PILA "P21"- fir stanga				
Pct.	Y-(EST)	X-(NORD)	Z	
S36-P21S-R01	231000.29	577768.71	87.34	
S36-P21S-R02	230999.51	577766.65	87.34	
S36-P21S-R03	230988.61	577770.76	87.34	
S36-P21S-R04	230989.38	577772.82	87.34	
TRASARE PILOTI PILA "P21"- fir stanga				
Pct.	Y-(EST)	X-(NORD)	Zsup	Zinf
S36-P21S-P01	230990.03	577771.40	87.44	63.34
S36-P21S-P02	230992.97	577770.29	87.44	63.34
S36-P21S-P03	230995.92	577769.18	87.44	63.34
S36-P21S-P04	230998.87	577768.07	87.44	63.34

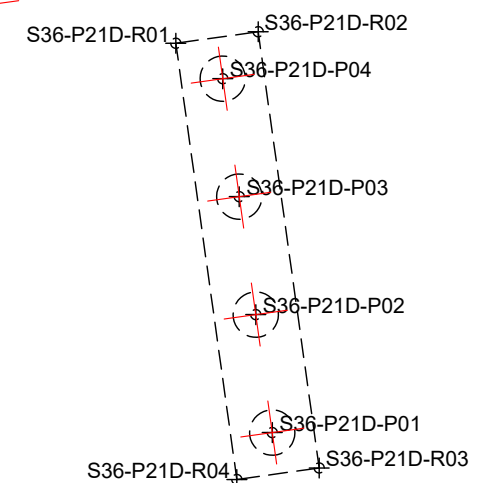

TRASARE RADIER PILA "P21"- fir dreapta				
Pct.	Y-(EST)	X-(NORD)	Z	
S36-P21D-R01	230986.25	577774.00	87.34	
S36-P21D-R02	230985.47	577771.94	87.34	
S36-P21D-R03	230974.57	577776.05	87.34	
S36-P21D-R04	230975.35	577778.11	87.34	
TRASARE PILOTI PILA "P21"- fir dreapta				
Pct.	Y-(EST)	X-(NORD)	Zsup	Zinf
S36-P21D-P01	230975.99	577776.69	87.44	63.34
S36-P21D-P02	230978.94	577775.58	87.44	63.34
S36-P21D-P03	230981.88	577774.47	87.44	63.34
S36-P21D-P04	230984.83	577773.36	87.44	63.34

<b>PROIECTANT / DESIGNER:</b> S.C. CONSITRANS S.R.L.		<b>BENEFICIAR / BENEFICIARY:</b> MUNICIPIUL ARAD, MUNICIPIUL ORADEA, CONSILIUL JUDETEAN ARAD, CONSILIUL JUDETEAN BIHOR CNAIR	<b>FUNCTIA / POSITION:</b> COORDONATOR DE PROIECT / PROJECT MANAGER	<b>NUME / NAME:</b> ing. S. VEACESLAV	SEMNATURA / SIGNATURE: 	<b>Titlu plansa / Drawing title:</b> Plan trasare - plan 11/12 Layout plan - plan 11/12	REV./REV.: R00	DATA/DATE: 11.2023	DETALII REVIZIE / REVISION DETAILS: P.T.E.	PROIECTAT / DESIGNER: Consitrans
		<b>INVESTITIA / INVESTMENT:</b> ACTUALIZARE/COMPLETARE/REVIZUIRE (S.F. + P.A.C. + P.O.E + P.T.E.) "DRUM EXPRES ARAD ORADEA" ACTUALIZATION/COMPLETION (S.F. + P.A.C. + P.O.E + P.T.E.) "EXPRESS ROAD ARAD ORADEA"	<b>SEF PROIECT SPECIALITATE / TEAM LEADER:</b> ing. D. COVELTIR	SEMNATURA / SIGNATURE: 			REV./REV.:	DATA/DATE:	DETALII REVIZIE / REVISION DETAILS:	PROIECTAT / DESIGNER:
		<b>FAZA PROIECTARE / DESIGN STAGE:</b> PROIECT TEHNIC DE EXECUTIE / EXECUTION TECHNICAL PROJECT	<b>PROIECTAT / DESIGNER:</b> ing. V. URDAREANU	SEMNATURA / SIGNATURE: 	SEMNATURA / SIGNATURE: 	<b>LUCRARI DE POD / BRIDGE WORKS</b>	REV./REV.:	DATA/DATE:	DETALII REVIZIE / REVISION DETAILS:	PROIECTAT / DESIGNER:
		Contract /Contract: 14724/01.07.2021 Data /Date: 11.2023 Scara /Scale: 1:200	<b>VERIFICAT / INTERNAL CHECKER:</b> ing. D. COVELTIR	SEMNATURA / SIGNATURE: 			REV./REV.:	DATA/DATE:	DETALII REVIZIE / REVISION DETAILS:	PROIECTAT / DESIGNER:
UNIUNEA EUROPEANA PROIECT CO-FINANAT DIN FONDUL DE COEZIUNE, PRIN PROGRAMUL OPERATIONAL INFRASTRUCTURA MARE / PROJECT CO-FINANCED FROM THE COHESION FUND, THROUGH THE LARGE INFRASTRUCTURE OPERATIONAL PROGRAM		Instrumente Structurale 2014-2020	Cod plansa / Drawing code: CST-0121-PTE-02-DX- 02-P36-PTR-11-R00							

# P22

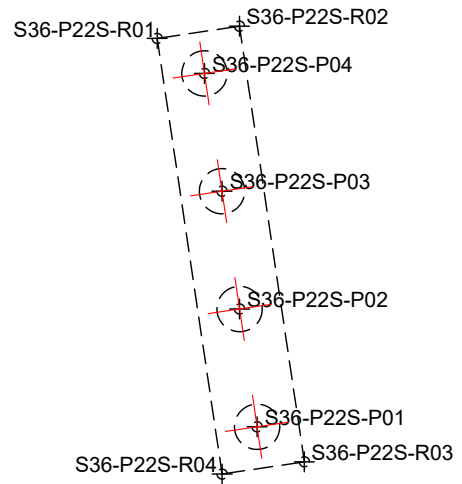
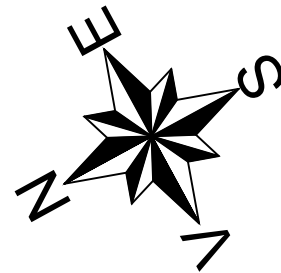

TRASARE RADIER PILA "P22"- fir stanga

Pct.	Y-(EST)	X-(NORD)	Z
S36-P22S-R01	230985.86	577729.93	87.53
S36-P22S-R02	230985.10	577727.86	87.53
S36-P22S-R03	230974.16	577731.87	87.53
S36-P22S-R04	230974.92	577733.94	87.53

TRASARE PILOTI PILA "P22"- fir stanga

Pct.	Y-(EST)	X-(NORD)	Zsup	Zinf
S36-P22S-P01	230975.57	577732.53	87.63	63.53
S36-P22S-P02	230978.53	577731.44	87.63	63.53
S36-P22S-P03	230981.49	577730.36	87.63	63.53
S36-P22S-P04	230984.45	577729.27	87.63	63.53

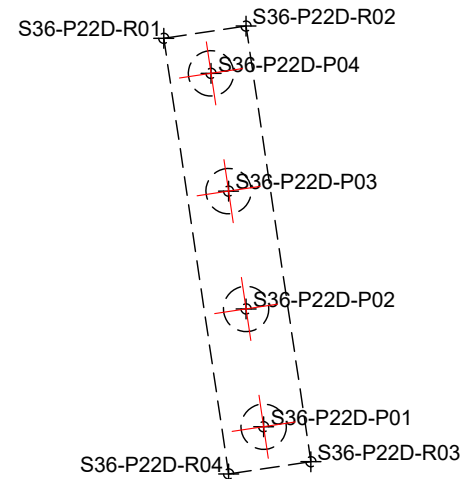

TRASARE RADIER PILA "P22"- fir dreapta

Pct.	Y-(EST)	X-(NORD)	Z
S36-P22D-R01	230971.78	577735.09	87.53
S36-P22D-R02	230971.02	577733.02	87.53
S36-P22D-R03	230960.08	577737.04	87.53
S36-P22D-R04	230960.84	577739.10	87.53

TRASARE PILOTI PILA "P22"- fir dreapta

Pct.	Y-(EST)	X-(NORD)	Zsup	Zinf
S36-P22D-P01	230961.49	577737.69	87.63	63.53
S36-P22D-P02	230964.45	577736.60	87.63	63.53
S36-P22D-P03	230967.41	577735.52	87.63	63.53
S36-P22D-P04	230970.36	577734.44	87.63	63.53

# C2

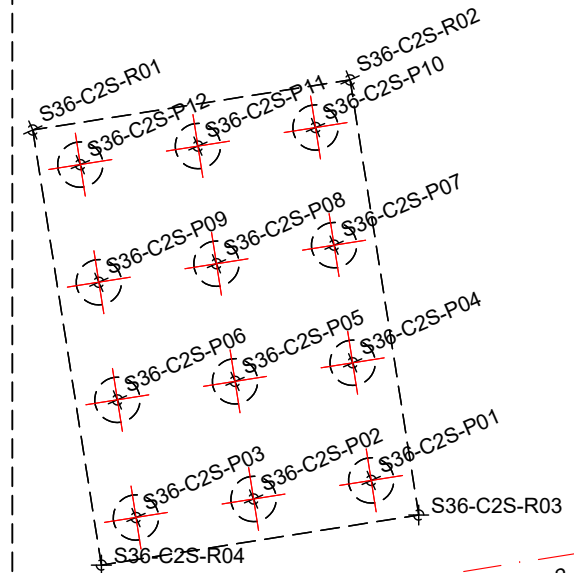

TRASARE RADIER CULEE "C2"-fir stg			
Pct.	X-(EST)	Y-(NORD)	Z
S36-C2S-R01	230973.59	577696.10	87.39
S36-C2S-R02	230970.73	577688.09	87.39
S36-C2S-R03	230959.76	577692.01	87.39
S36-C2S-R04	230962.62	577700.01	87.39

TRASARE PILOTI CULEE "C2"-fir stg				
Pct.	X-(EST)	Y-(NORD)	Zsup	Zinf
S36-C2S-P01	230961.16	577692.67	87.49	63.39
S36-C2S-P02	230962.22	577695.64	87.49	63.39
S36-C2S-P03	230963.28	577698.61	87.49	63.39
S36-C2S-P04	230964.13	577691.62	87.49	63.39
S36-C2S-P05	230965.19	577694.58	87.49	63.39
S36-C2S-P06	230966.25	577697.55	87.49	63.39
S36-C2S-P07	230967.10	577690.56	87.49	63.39
S36-C2S-P08	230968.16	577693.52	87.49	63.39
S36-C2S-P09	230969.22	577696.49	87.49	63.39
S36-C2S-P10	230970.06	577689.50	87.49	63.39
S36-C2S-P11	230971.12	577692.46	87.49	63.39
S36-C2S-P12	230972.18	577695.43	87.49	63.39

TRASARE RADIER CULEE "C2"-fir dr			
Pct.	X-(EST)	Y-(NORD)	Z
S36-C2D-R01	230959.46	577701.14	87.39
S36-C2D-R02	230956.60	577693.13	87.39
S36-C2D-R03	230945.63	577697.05	87.39
S36-C2D-R04	230948.49	577705.06	87.39

TRASARE PILOTI CULEE "C2"-fir dr				
Pct.	X-(EST)	Y-(NORD)	Zsup	Zinf
S36-C2D-P01	230947.04	577697.72	87.49	63.39
S36-C2D-P02	230948.10	577700.68	87.49	63.39
S36-C2D-P03	230949.16	577703.65	87.49	63.39
S36-C2D-P04	230950.00	577696.66	87.49	63.39
S36-C2D-P05	230951.06	577699.63	87.49	63.39
S36-C2D-P06	230952.12	577702.59	87.49	63.39
S36-C2D-P07	230952.97	577695.60	87.49	63.39
S36-C2D-P08	230954.03	577698.57	87.49	63.39
S36-C2D-P09	230955.09	577701.53	87.49	63.39
S36-C2D-P10	230955.94	577694.54	87.49	63.39
S36-C2D-P11	230957.00	577697.51	87.49	63.39
S36-C2D-P12	230958.06	577700.47	87.49	63.39

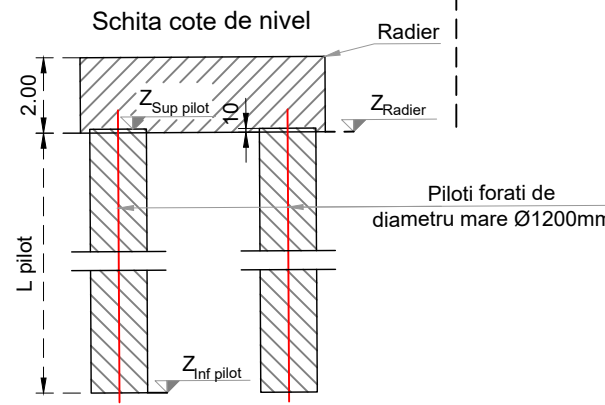

<b>PROIECTANT / DESIGNER:</b> S.C. CONSITRANS S.R.L.	<b>BENEFICIAR / BENEFICIARY:</b> MUNICIPIUL ARAD, MUNICIPIUL ORADEA, CONSILIUL JUDETEAN ARAD, CONSILIUL JUDETEAN BIHOR CNAIR	<b>FUNCTIA / POSITION:</b> COORDONATOR DE PROIECT / PROJECT MANAGER	<b>NUME / NAME:</b> ing. S. VEACESLAV	<b>SEMNTATURA / SIGNATURE:</b> 	<b>Titlu plansa / Drawing title:</b> Plan trasare - plan 12/12 Layout plan - plan 12/12	<b>REV./REV.:</b> R00	<b>DATA/DATE:</b> 11.2023	<b>DETALII REVIZIE / REVISION DETAILS:</b> P.T.E.	<b>PROIECTAT / DESIGNER:</b> Consitrans
						<b>INVESTITIA / INVESTMENT:</b> ACTUALIZARE/COMPLETARE/REVIZUIRE (S.F. + P.A.C. + P.O.E + P.T.E.) "DRUM EXPRES ARAD ORADEA" ACTUALIZATION/COMPLETION (S.F. + P.A.C. + P.O.E + P.T.E.) "EXPRESS ROAD ARAD ORADEA"	<b>SEF PROIECT SPECIALITATE / TEAM LEADER:</b> ing. D. COVELTIR	<b>PROIECTAT / DESIGNER:</b> ing. V. URDAREANU	<b>Cod plansa / Drawing code:</b> CST-0121-PTE-02-DX- 02-P36-PTR-12-R00
UNIUNEA EUROPEANA PROIECT CO-FINANAT DIN FONDUL DE COEZIUNE, PRIN PROGRAMUL OPERATIONAL INFRASTRUCTURA MARE / PROJECT CO-FINANCED FROM THE COHESION FUND, THROUGH THE LARGE INFRASTRUCTURE OPERATIONAL PROGRAM	GUVERNUL ROMANIEI Instrumente Structurale 2014-2020	<b>FAZA PROIECTARE / DESIGN STAGE:</b> PROIECT TEHNIC DE EXECUTIE / EXECUTION TECHNICAL PROJECT	<b>PROIECTAT / DESIGNER:</b> ing. D. COVELTIR	<b>VERIFICAT / INTERNAL CHECKER:</b> 					
		<b>Contract /Contract:</b> 14724/01.07.2021 <b>Project /Project no.:</b> 001/2021	<b>Data / Date:</b> 11.2023	<b>Scara /Scale:</b> 1:200					