

TRASARE RADIER CULEE "C1"-fir stg

Pct.	X-(EST)	Y-(NORD)	Z
S40-C1S-R01	231936.78	565759.46	89.9
S40-C1S-R02	231931.89	565752.5	89.9
S40-C1S-R03	231922.36	565759.21	89.9
S40-C1S-R04	231927.25	565766.16	89.9

TRASARE PILOTI CULEE "C1"-fir stg

Pct.	X-(EST)	Y-(NORD)	Zsup	Zinf
S40-C1S-P01	231935.25	565759.19	90	67.9
S40-C1S-P02	231933.44	565756.61	90	67.9
S40-C1S-P03	231931.62	565754.04	90	67.9
S40-C1S-P04	231932.67	565761	90	67.9
S40-C1S-P05	231930.86	565758.43	90	67.9
S40-C1S-P06	231929.05	565755.85	90	67.9
S40-C1S-P07	231930.09	565762.81	90	67.9
S40-C1S-P08	231928.28	565760.24	90	67.9
S40-C1S-P09	231926.47	565757.66	90	67.9
S40-C1S-P10	231927.52	565764.63	90	67.9
S40-C1S-P11	231925.71	565762.05	90	67.9
S40-C1S-P12	231923.89	565759.47	90	67.9

TRASARE RADIER CULEE "C1"-fir dr

Pct.	X-(EST)	Y-(NORD)	Z
S40-C1D-R01	231924.51	565768.09	89.90
S40-C1D-R02	231919.62	565761.13	89.90
S40-C1D-R03	231910.09	565767.83	89.90
S40-C1D-R04	231914.98	565774.79	89.90

TRASARE PILOTI CULEE "C1"-fir dr

Pct.	X-(EST)	Y-(NORD)	Zsup	Zinf
S40-C1D-P01	231922.98	565767.82	90.00	67.90
S40-C1D-P02	231921.17	565765.24	90.00	67.90
S40-C1D-P03	231919.35	565762.67	90.00	67.90
S40-C1D-P04	231920.4	565769.63	90.00	67.90
S40-C1D-P05	231918.59	565767.05	90.00	67.90
S40-C1D-P06	231916.78	565764.48	90.00	67.90
S40-C1D-P07	231917.82	565771.44	90.00	67.90
S40-C1D-P08	231916.01	565768.87	90.00	67.90
S40-C1D-P09	231914.2	565766.29	90.00	67.90
S40-C1D-P10	231915.25	565773.25	90.00	67.90
S40-C1D-P11	231913.44	565770.68	90.00	67.90
S40-C1D-P12	231911.62	565768.1	90.00	67.90

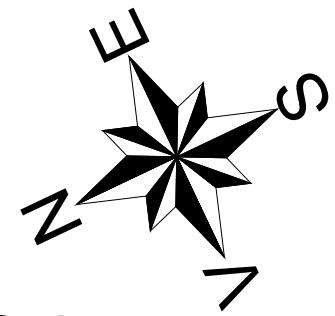

C1

Oradea

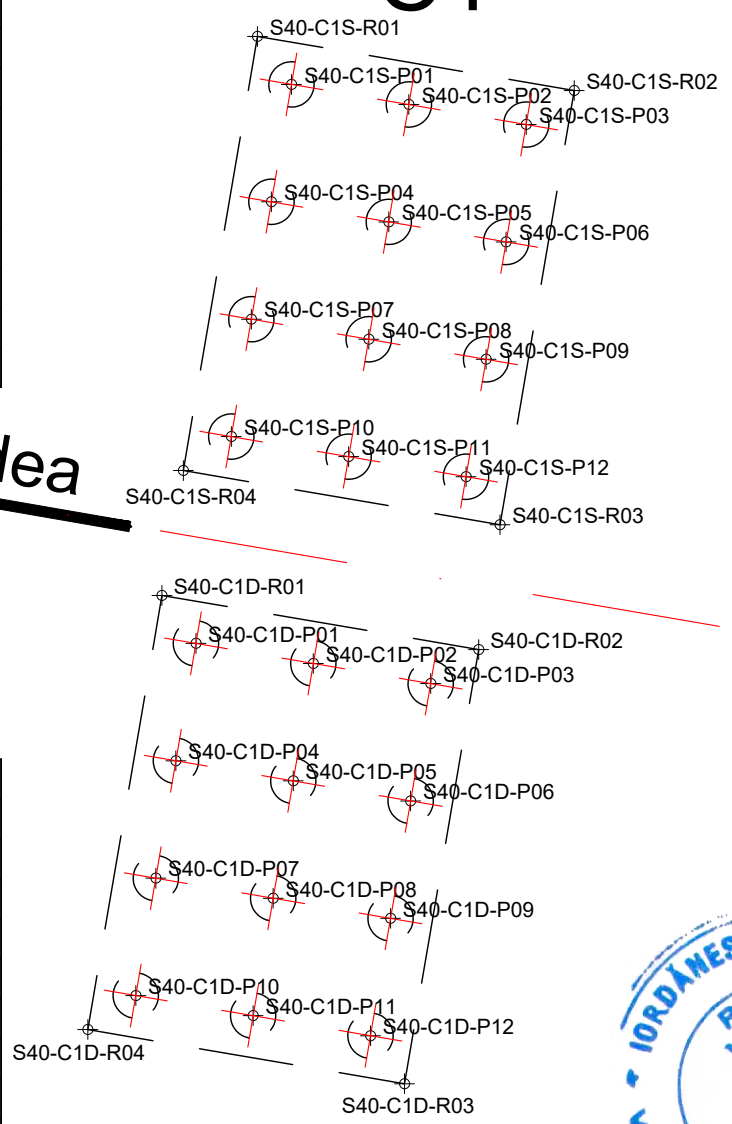

TRASARE RADIER PILA "P1"- fir stanga

Pct.	Y-(EST)	X-(NORD)	Z
S40-P1S-R01	231912.39	565724.78	89.47
S40-P1S-R02	231911.13	565722.98	89.47
S40-P1S-R03	231901.60	565729.68	89.47
S40-P1S-R04	231902.86	565731.48	89.47

TRASARE PILOTI PILA "P1"- fir stanga

Pct.	Y-(EST)	X-(NORD)	Zsup	Zinf
S40-P1S-P01	231910.86	565724.51	89.57	67.47
S40-P1S-P02	231908.28	565726.32	89.57	67.47
S40-P1S-P03	231905.71	565728.13	89.57	67.47
S40-P1S-P04	231903.13	565729.94	89.57	67.47

TRASARE RADIER PILA "P1"- fir dreapta

Pct.	Y-(EST)	X-(NORD)	Z
S40-P1D-R01	231900.12	565733.40	89.62
S40-P1D-R02	231898.86	565731.60	89.62
S40-P1D-R03	231889.32	565738.30	89.62
S40-P1D-R04	231890.59	565740.10	89.62

TRASARE PILOTI PILA "P1"- fir dreapta

Pct.	Y-(EST)	X-(NORD)	Zsup	Zinf
S40-P1D-P01	231898.59	565733.13	89.72	67.62
S40-P1D-P02	231896.01	565734.95	89.72	67.62
S40-P1D-P03	231893.43	565736.76	89.72	67.62
S40-P1D-P04	231890.86	565738.57	89.72	67.62

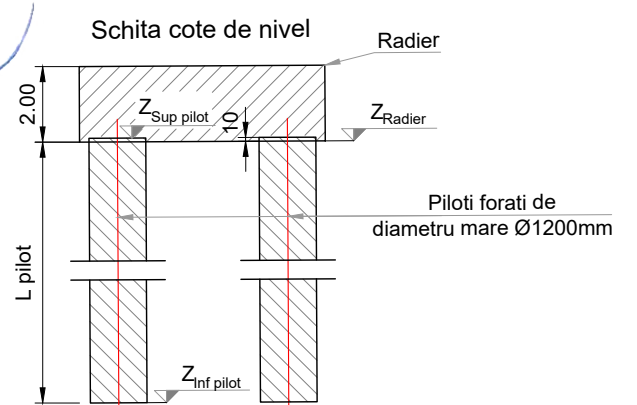
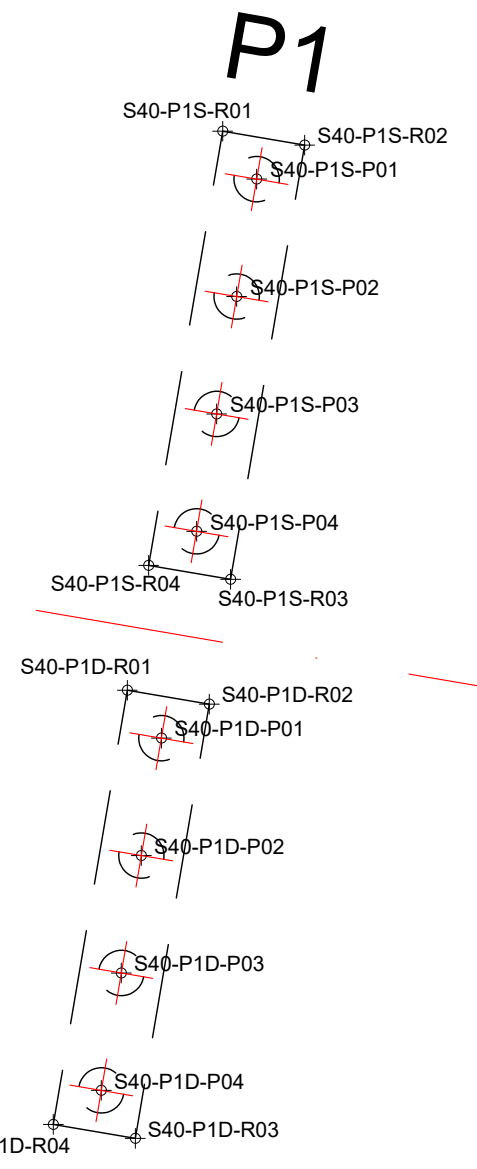

PROIECTANT / DESIGNER: <b>S.C. CONSITRANS S.R.L.</b>	BENEFICIAR / BENEFICIARY: MUNICIPIUL ARAD, MUNICIPIUL ORADEA, CONSILIUL JUDETEAN ARAD, CONSILIUL JUDETEAN BIHOR CNAIR	FUNCTIA / POSITION: COORDONATOR DE PROIECT / PROJECT MANAGER	NUME / NAME: ing. S. VEACESLAV	SEMNATURA / SIGNATURE: 	Titlu plansa / Drawing title: Plan trasare - plan 1 / 12 Layout plan - drawing 1 / 12	REV. / REV.: R00	DATA / DATE: 11.2023	DETALII REVIZIE / REVISION DETAILS: P.T.E.	PROIECTAT / DESIGNER: Consitrans
						INVESTITIA / INVESTMENT: ACTUALIZARE/COMPLETARE/REVIZUIRE (S.F. + P.A.C. + P.O.E + P.T.E.) "DRUM EXPRES ARAD ORADEA" ACTUALIZATION/COMPLETION (S.F. + P.A.C. + P.O.E + P.T.E.) "EXPRESS ROAD ARAD ORADEA"	SEF PROIECT SPECIALITATE / TEAM LEADER: ing. D. COVELTIR	FAZA PROIECTARE / DESIGN STAGE: PROIECT TEHNIC DE EXECUTIE / EXECUTION TECHNICAL PROJECT	PROIECTAT / DESIGNER: ing. V. URDAREANU
Contract /Contract: 14724/01.07.2021 Project /Project no.: 001/2021	Data / Date: 11.2023	Scara /Scale: 1:200	VERIFICAT / INTERNAL CHECKER: ing. D. COVELTIR	SEMNATURA / SIGNATURE: 	Pod pe DX la km 71+700 peste raul Crisul Alb Bridge on DX at km 71+700 over Crisul Alb river				

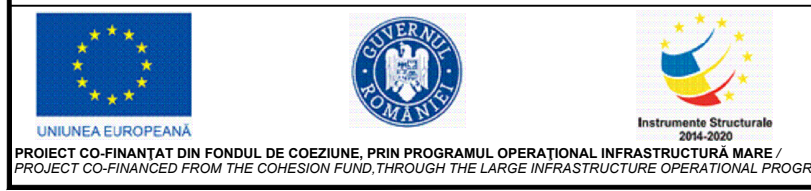

TRASARE RADIER PILA "P2"- fir stanga

Pct.	Y-(EST)	X-(NORD)	Z
S40-P2S-R01	231888.54	565690.84	90.15
S40-P2S-R02	231887.28	565689.04	90.15
S40-P2S-R03	231877.74	565695.72	90.15
S40-P2S-R04	231879.00	565697.53	90.15

TRASARE PILOTI PILA "P2"- fir stanga

Pct.	Y-(EST)	X-(NORD)	Zsup	Zinf
S40-P2S-P01	231887.01	565690.57	90.25	68.15
S40-P2S-P02	231884.43	565692.38	90.25	68.15
S40-P2S-P03	231881.85	565694.19	90.25	68.15
S40-P2S-P04	231879.27	565695.99	90.25	68.15

TRASARE RADIER PILA "P2"- fir dreapta

Pct.	Y-(EST)	X-(NORD)	Z
S40-P2D-R01	231876.25	565699.45	89.99
S40-P2D-R02	231874.99	565697.65	89.99
S40-P2D-R03	231865.45	565704.33	89.99
S40-P2D-R04	231866.71	565706.13	89.99

TRASARE PILOTI PILA "P2"- fir dreapta

Pct.	Y-(EST)	X-(NORD)	Zsup	Zinf
S40-P2D-P01	231874.72	565699.18	90.09	67.99
S40-P2D-P02	231872.14	565700.99	90.09	67.99
S40-P2D-P03	231869.56	565702.79	90.09	67.99
S40-P2D-P04	231866.98	565704.60	90.09	67.99

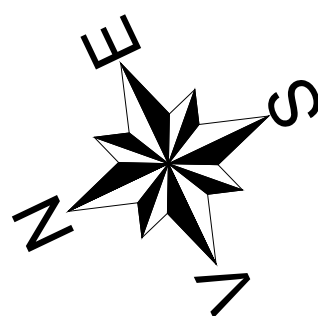

P2

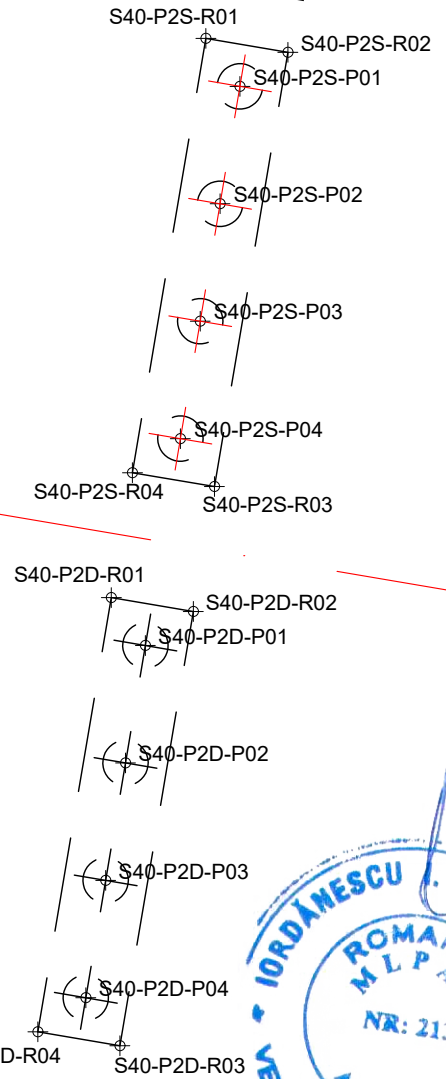

TRASARE RADIER PILA "P3"- fir stanga

Pct.	Y-(EST)	X-(NORD)	Z
S40-P3S-R01	231866	565658.53	90.10
S40-P3S-R02	231863.06	565654.25	90.10
S40-P3S-R03	231853.5	565660.83	90.10
S40-P3S-R04	231856.45	565665.11	90.10

TRASARE PILOTI PILA "P3"- fir stanga

Pct.	Y-(EST)	X-(NORD)	Zsup	Zinf
S40-P3S-P01	231864.5	565658.24	90.20	68.10
S40-P3S-P02	231862.79	565655.76	90.20	68.10
S40-P3S-P03	231861.9	565660.02	90.20	68.10
S40-P3S-P04	231860.2	565657.55	90.20	68.10
S40-P3S-P05	231859.31	565661.81	90.20	68.10
S40-P3S-P06	231857.61	565659.34	90.20	68.10
S40-P3S-P07	231856.71	565663.59	90.20	68.10
S40-P3S-P08	231855.01	565661.12	90.20	68.10

P3

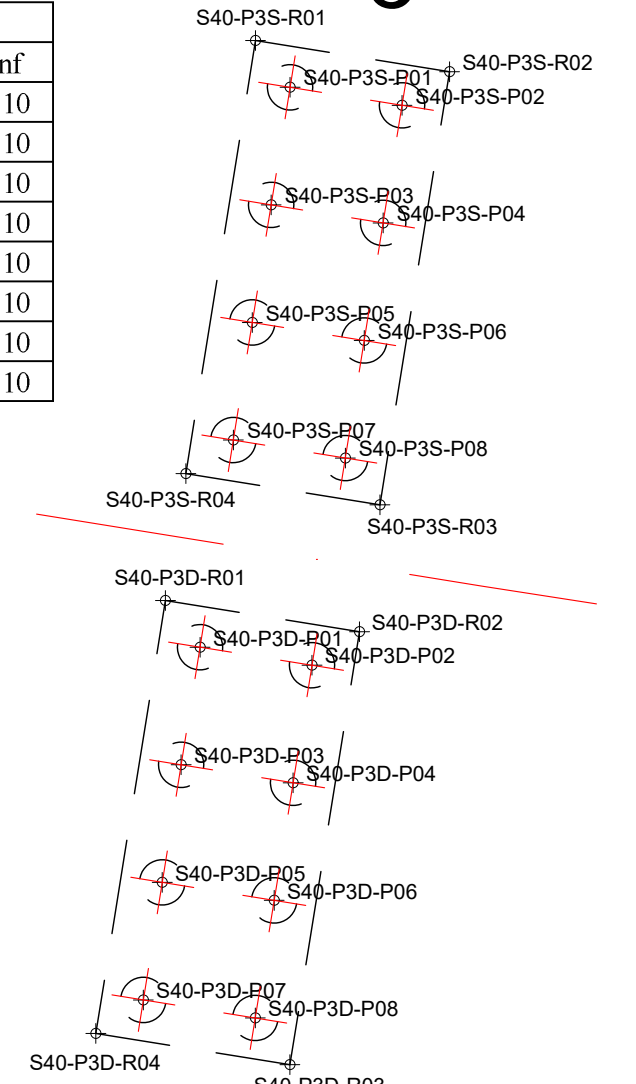

TRASARE RADIER PILA "P3"- fir dreapta

Pct.	Y-(EST)	X-(NORD)	Z
S40-P3D-R01	231853.65	565667.04	90.04
S40-P3D-R02	231850.7	565662.76	90.04
S40-P3D-R03	231841.15	565669.33	90.04
S40-P3D-R04	231844.1	565673.62	90.04

TRASARE PILOTI PILA "P3"- fir dreapta

Pct.	Y-(EST)	X-(NORD)	Zsup	Zinf
S40-P3D-P01	231852.14	565666.74	90.14	68.04
S40-P3D-P02	231850.44	565664.27	90.14	68.04
S40-P3D-P03	231849.55	565668.53	90.14	68.04
S40-P3D-P04	231847.85	565666.06	90.14	68.04
S40-P3D-P05	231846.95	565670.32	90.14	68.04
S40-P3D-P06	231845.25	565667.84	90.14	68.04
S40-P3D-P07	231844.36	565672.1	90.14	68.04
S40-P3D-P08	231842.66	565669.63	90.14	68.04

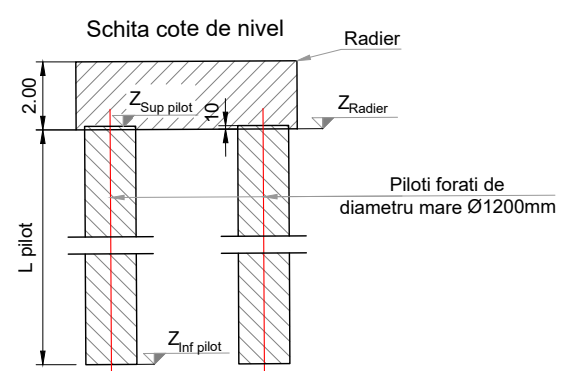

<b>PROIECTANT / DESIGNER:</b> S.C. CONSITRANS S.R.L.	<b>BENEFICIAR / BENEFICIARY:</b> MUNICIPIUL ARAD, MUNICIPIUL ORADEA, CONSILIUL JUDETEAN ARAD, CONSILIUL JUDETEAN BIHOR CNAIR	<b>FUNCTIA / POSITION:</b> COORDONATOR DE PROIECT / PROJECT MANAGER	<b>NUME / NAME:</b> ing. S. VEACESLAV	<b>SEMNATURA / SIGNATURE:</b> 	<b>Titlu plansa / Drawing title:</b> Plan trasare - plan 2 / 12 Layout plan - drawing 2 / 12	<b>REV. / REV.:</b> R00	<b>DATA / DATE:</b> 11.2023	<b>DETALII REVIZIE / REVISION DETAILS:</b> P.T.E.	<b>PROIECTAT / DESIGNER:</b> Consitrans
UNIUNEA EUROPEANA PROIECT CO-FINANTAT DIN FONDUL DE COEZIUNE, PRIN PROGRAMUL OPERATIONAL INFRASTRUCTURA MARE / PROJECT CO-FINANCED FROM THE COHESION FUND, THROUGH THE LARGE INFRASTRUCTURE OPERATIONAL PROGRAM	ROMANIA M.L.P.A.T. NR: 213 VERIFICATOR PROIECTE AS, B2, D2	<b>FAZA PROIECTARE / DESIGN STAGE:</b> PROIECT TEHNIC DE EXECUTIE / EXECUTION TECHNICAL PROJECT	<b>VERIFICAT / INTERNAL CHECKER:</b> ing. D. COVELTIR	<b>Contract / Contract:</b> 14724/01.07.2021	<b>Data / Date:</b> 11.2023	<b>Scara / Scale:</b> 1:200			



TRASARE RADIER PILA "P4"- fir stanga

Pct.	Y-(EST)	X-(NORD)	Z
S40-P4S-R01	231842.29	565623.52	89.98
S40-P4S-R02	231841.07	565621.69	89.98
S40-P4S-R03	231831.37	565628.15	89.98
S40-P4S-R04	231832.59	565629.98	89.98

TRASARE PILOTI PILA "P4"- fir stanga

Pct.	Y-(EST)	X-(NORD)	Zsup	Zinf
S40-P4S-P01	231840.76	565623.22	90.08	67.98
S40-P4S-P02	231838.14	565624.96	90.08	67.98
S40-P4S-P03	231835.51	565626.71	90.08	67.98
S40-P4S-P04	231832.89	565628.45	90.08	67.98

TRASARE RADIER PILA "P4"- fir dreapta

Pct.	Y-(EST)	X-(NORD)	Z
S40-P4D-R01	231829.80	565631.83	89.99
S40-P4D-R02	231828.58	565630.00	89.99
S40-P4D-R03	231818.88	565636.45	89.99
S40-P4D-R04	231820.10	565638.29	89.99

TRASARE PILOTI PILA "P4"- fir dreapta

Pct.	Y-(EST)	X-(NORD)	Zsup	Zinf
S40-P4D-P01	231828.27	565631.53	90.09	67.99
S40-P4D-P02	231825.65	565633.27	90.09	67.99
S40-P4D-P03	231823.03	565635.02	90.09	67.99
S40-P4D-P04	231820.40	565636.76	90.09	67.99

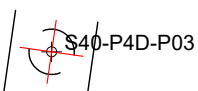
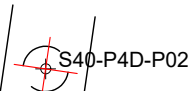
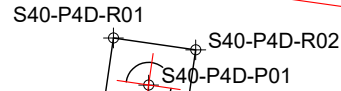
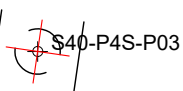
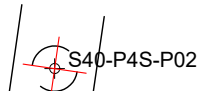
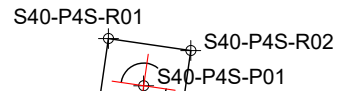
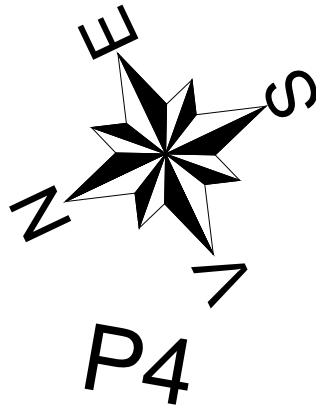

TRASARE RADIER PILA "P5"- fir stanga

Pct.	Y-(EST)	X-(NORD)	Z
S40-P5S-R01	231819.89	565588.99	90.18
S40-P5S-R02	231818.71	565587.13	90.18
S40-P5S-R03	231808.85	565593.33	90.18
S40-P5S-R04	231810.03	565595.20	90.18

TRASARE PILOTI PILA "P5"- fir stanga

Pct.	Y-(EST)	X-(NORD)	Zsup	Zinf
S40-P5S-P01	231818.37	565588.65	90.28	68.18
S40-P5S-P02	231815.70	565590.32	90.28	68.18
S40-P5S-P03	231813.04	565592.00	90.28	68.18
S40-P5S-P04	231810.37	565593.68	90.28	68.18

TRASARE RADIER PILA "P5"- fir dreapta

Pct.	Y-(EST)	X-(NORD)	Z
S40-P5D-R01	231807.19	565596.98	90.28
S40-P5D-R02	231806.02	565595.12	90.28
S40-P5D-R03	231796.16	565601.32	90.28
S40-P5D-R04	231797.33	565603.19	90.28

TRASARE PILOTI PILA "P5"- fir dreapta

Pct.	Y-(EST)	X-(NORD)	Zsup	Zinf
S40-P5D-P01	231805.67	565596.64	90.38	68.28
S40-P5D-P02	231803.01	565598.31	90.38	68.28
S40-P5D-P03	231800.34	565599.99	90.38	68.28
S40-P5D-P04	231797.68	565601.67	90.38	68.28

P5

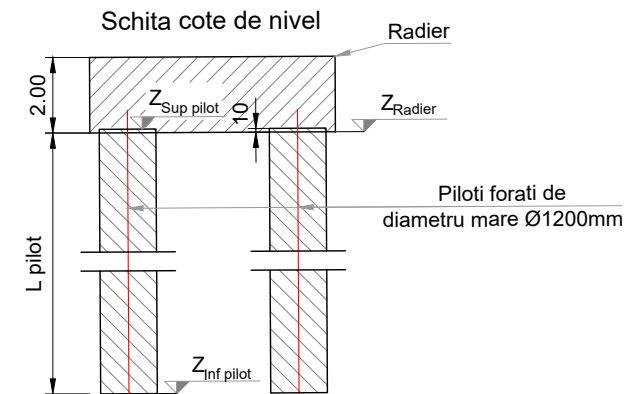
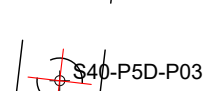
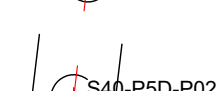
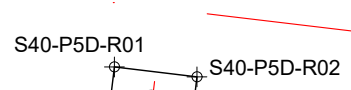
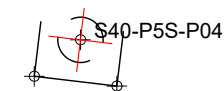
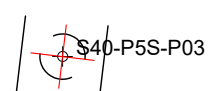
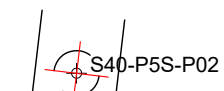
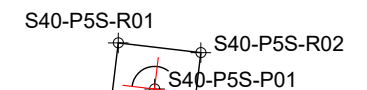

PROIECTANT / DESIGNER: <b>S.C. CONSITRANS S.R.L.</b>	BENEFICIAR / BENEFICIARY: MUNICIPIUL ARAD, MUNICIPIUL ORADEA, CONSILIUL JUDETEAN ARAD, CONSILIUL JUDETEAN BIHOR CNAIR	FUNCTIA / POSITION: COORDONATOR DE PROIECT / PROJECT MANAGER	NUME / NAME: ing. S. VEACESLAV	SEMNATURA / SIGNATURE: 	Titlu plansa / Drawing title: Plan trasare - plan 3 / 12 Layout plan - drawing 3 / 12	REV. / REV.: R00	DATA / DATE: 11.2023	DETALII REVIZIE / REVISION DETAILS: P.T.E.	PROIECTAT / DESIGNER: Consitrans
						INVESTITIA / INVESTMENT: ACTUALIZARE/COMPLETARE/REVIZUIRE (S.F. + P.A.C. + P.O.E + P.T.E.) "DRUM EXPRES ARAD ORADEA" ACTUALIZATION/COMPLETION (S.F. + P.A.C. + P.O.E + P.T.E.) "EXPRESS ROAD ARAD ORADEA"	SEF PROIECT SPECIALITATE / TEAM LEADER: ing. D. COVELTIR	FAZA PROIECTARE / DESIGN STAGE: PROIECT TEHNIC DE EXECUTIE / EXECUTION TECHNICAL PROJECT	PROIECTAT / DESIGNER: ing. V. URDAREANU
UNIUNEA EUROPEANA PROIECT CO-FINANATAT DIN FONDUL DE COEZIUNE, PRIN PROGRAMUL OPERATIONAL INFRASTRUCTURA MARE / PROJECT CO-FINANCED FROM THE COHESION FUND, THROUGH THE LARGE INFRASTRUCTURE OPERATIONAL PROGRAM	GUVERNUL ROMANIEI Instrumente Structurale 2014-2020	Contract /Contract: 14724/01.07.2021 Data / Date: 11.2023 Scara /Scale: 1:200	VERIFICAT / INTERNAL CHECKER: ing. D. COVELTIR	SEMNATURA / SIGNATURE: 	Pod pe DX la km 71+700 peste raul Crisul Alb Bridge on DX at km 71+700 over Crisul Alb river	LUCRARI DE POD / BRIDGE WORKS			

TRASARE RADIER PILA "P6"- fir stanga			
Pct.	Y-(EST)	X-(NORD)	Z
S40-P6S-R01	231799.43	565555.63	89.69
S40-P6S-R02	231796.78	565551.15	89.69
S40-P6S-R03	231786.8	565557.06	89.69
S40-P6S-R04	231789.45	565561.54	89.69

TRASARE PILOTI PILA "P6"- fir stanga				
Pct.	Y-(EST)	X-(NORD)	Zsup	Zinf
S40-P6S-P01	231797.95	565555.23	89.79	67.69
S40-P6S-P02	231796.42	565552.65	89.79	67.69
S40-P6S-P03	231795.23	565556.83	89.79	67.69
S40-P6S-P04	231793.71	565554.25	89.79	67.69
S40-P6S-P05	231792.52	565558.44	89.79	67.69
S40-P6S-P06	231791	565555.86	89.79	67.69
S40-P6S-P07	231789.81	565560.04	89.79	67.69
S40-P6S-P08	231788.28	565557.46	89.79	67.69

TRASARE RADIER PILA "P6"- fir dreapta			
Pct.	Y-(EST)	X-(NORD)	Z
S40-P6D-R01	231786.52	565563.27	89.79
S40-P6D-R02	231783.87	565558.79	89.79
S40-P6D-R03	231773.89	565564.7	89.79
S40-P6D-R04	231776.54	565569.17	89.79

TRASARE PILOTI PILA "P6"- fir dreapta				
Pct.	Y-(EST)	X-(NORD)	Zsup	Zinf
S40-P6D-P01	231785.04	565562.87	89.89	67.79
S40-P6D-P02	231783.51	565560.29	89.89	67.79
S40-P6D-P03	231782.33	565564.47	89.89	67.79
S40-P6D-P04	231780.8	565561.89	89.89	67.79
S40-P6D-P05	231779.61	565566.08	89.89	67.79
S40-P6D-P06	231778.09	565563.49	89.89	67.79
S40-P6D-P07	231776.9	565567.68	89.89	67.79
S40-P6D-P08	231775.38	565565.1	89.89	67.79

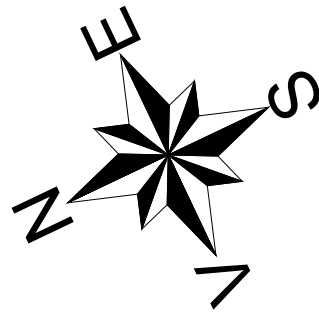

P6

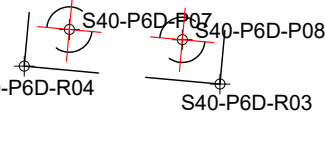
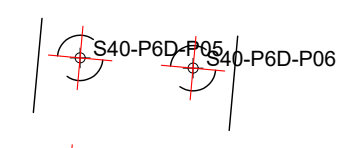
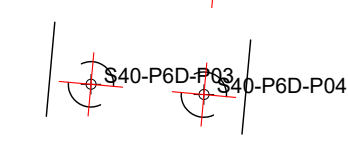
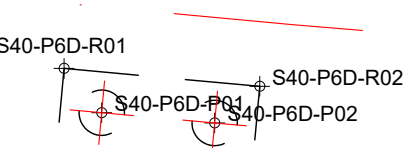
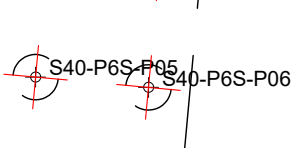
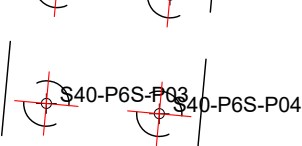
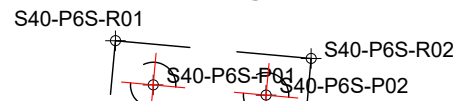

TRASARE RADIER PILA "P7"- fir stanga			
Pct.	Y-(EST)	X-(NORD)	Z
S40-P7S-R01	231778.45	565519.09	90.07
S40-P7S-R02	231777.38	565517.17	90.07
S40-P7S-R03	231767.19	565522.82	90.07
S40-P7S-R04	231768.26	565524.75	90.07

TRASARE PILOTI PILA "P7"- fir stanga				
Pct.	Y-(EST)	X-(NORD)	Zsup	Zinf
S40-P7S-P01	231776.95	565518.66	90.17	68.07
S40-P7S-P02	231774.20	565520.19	90.17	68.07
S40-P7S-P03	231771.44	565521.72	90.17	68.07
S40-P7S-P04	231768.69	565523.25	90.17	68.07

TRASARE RADIER PILA "P7"- fir dreapta			
Pct.	Y-(EST)	X-(NORD)	Z
S40-P7D-R01	231765.33	565526.37	90.17
S40-P7D-R02	231764.27	565524.45	90.17
S40-P7D-R03	231754.08	565530.11	90.17
S40-P7D-R04	231755.15	565532.03	90.17

TRASARE PILOTI PILA "P7"- fir dreapta				
Pct.	Y-(EST)	X-(NORD)	Zsup	Zinf
S40-P7D-P01	231763.84	565525.95	90.27	68.17
S40-P7D-P02	231761.08	565527.48	90.27	68.17
S40-P7D-P03	231758.33	565529.01	90.27	68.17
S40-P7D-P04	231755.58	565530.54	90.27	68.17

P7

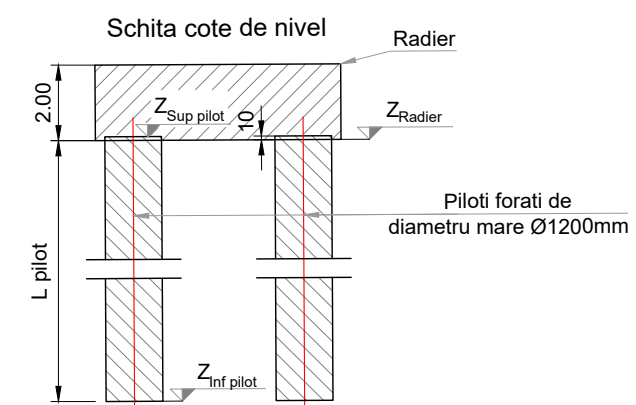
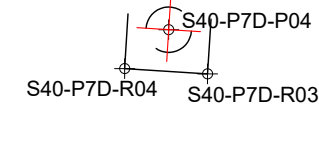
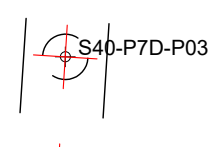
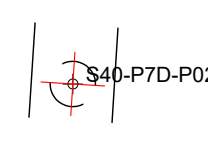
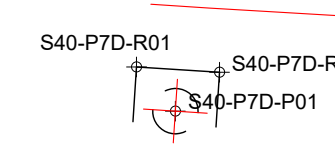
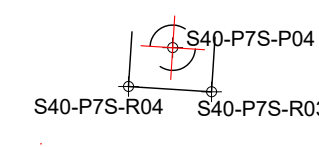
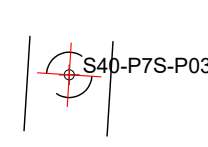
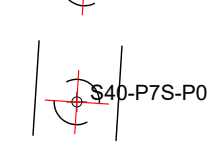
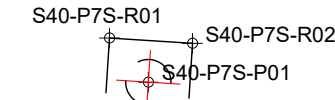

<b>PROIECTANT / DESIGNER:</b> <b>S.C. CONSITRANS S.R.L.</b>	<b>BENEFICIAR / BENEFICIARY:</b> <b>MUNICIPIUL ARAD, MUNICIPIUL ORADEA, CONSILIUL JUDETEAN ARAD, CONSILIUL JUDETEAN BIHOR CNAIR</b>	<b>FUNCTIA / POSITION:</b> <b>COORDONATOR DE PROIECT / PROJECT MANAGER</b>	<b>NUME / NAME:</b> ing. S. VEACESLAV	<b>SEMNATURA / SIGNATURE:</b> 	<b>Titlu plansa / Drawing title:</b> Plan trasare - plan 4 / 12 Layout plan - drawing 4 / 12	<b>REV. / REV.:</b> R00	<b>DATA / DATE:</b> 11.2023	<b>DETALII REVIZIE / REVISION DETAILS:</b> P.T.E.	<b>PROIECTAT / DESIGNER:</b> Consitrans
		<b>INVESTITIA / INVESTMENT:</b> <b>ACTUALIZARE/COMPLETARE/REVIZUIRE (S.F. + P.A.C. + P.O.E + P.T.E.) "DRUM EXPRES ARAD ORADEA"</b> <b>ACTUALIZATION/COMPLETION (S.F. + P.A.C. + P.O.E + P.T.E.) "EXPRESS ROAD ARAD ORADEA"</b>	<b>SEF PROIECT SPECIALITATE / TEAM LEADER</b> ing. D. COVELTIR			<b>Pod pe DX la km 71+700 peste raul Crisul Alb</b> <b>Bridge on DX at km 71+700 over Crisul Alb river</b>			
 UNIUNEA EUROPEANA PROIECT CO-FINANAT DIN FONDUL DE COEZIUNE, PRIN PROGRAMUL OPERATIONAL INFRASTRUCTURA MARE / PROJECT CO-FINANCED FROM THE COHESION FUND, THROUGH THE LARGE INFRASTRUCTURE OPERATIONAL PROGRAM	 GUVERNUL ROMANIEI Instrumente Structurale 2014-2020	<b>FAZA PROIECTARE / DESIGN STAGE:</b> <b>PROIECT TEHNIC DE EXECUTIE / EXECUTION TECHNICAL PROJECT</b>	<b>PROIECTAT / DESIGNER:</b> ing. V. URDAREANU		<b>LUCRARI DE POD / BRIDGE WORKS</b>				
		<b>Contract /Contract:</b> 14724/01.07.2021 <b>Project /Project no.:</b> 001/2021	<b>Data /Date:</b> 11.2023	<b>Scara /Scale:</b> 1:200	<b>VERIFICAT / INTERNAL CHECKER:</b> ing. D. COVELTIR		<b>Cod plansa / Drawing code:</b> CST-0121-PTE-02-DX- 02-P40-PTR-04-R00		



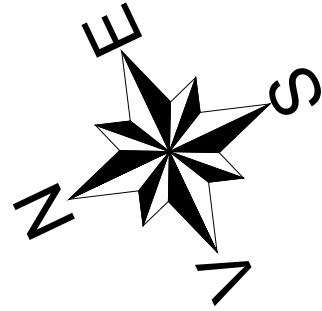

TRASARE RADIER PILA "P8"- fir stanga			
Pct.	Y-(EST)	X-(NORD)	Z
S40-P8S-R01	231758.95	565482.88	89.85
S40-P8S-R02	231757.93	565480.92	89.85
S40-P8S-R03	231747.59	565486.30	89.85
S40-P8S-R04	231748.61	565488.25	89.85

TRASARE PILOTI PILA "P8"- fir stanga				
Pct.	Y-(EST)	X-(NORD)	Zsup	Zinf
S40-P8S-P01	231757.46	565482.41	89.95	67.85
S40-P8S-P02	231754.67	565483.86	89.95	67.85
S40-P8S-P03	231751.87	565485.31	89.95	67.85
S40-P8S-P04	231749.08	565486.77	89.95	67.85

TRASARE RADIER PILA "P8"- fir dreapta			
Pct.	Y-(EST)	X-(NORD)	Z
S40-P8D-R01	231745.64	565489.79	89.75
S40-P8D-R02	231744.62	565487.84	89.75
S40-P8D-R03	231734.29	565493.22	89.75
S40-P8D-R04	231735.30	565495.17	89.75

TRASARE PILOTI PILA "P8"- fir dreapta				
Pct.	Y-(EST)	X-(NORD)	Zsup	Zinf
S40-P8D-P01	231744.15	565489.33	89.85	67.75
S40-P8D-P02	231741.36	565490.78	89.85	67.75
S40-P8D-P03	231738.56	565492.23	89.85	67.75
S40-P8D-P04	231735.77	565493.68	89.85	67.75

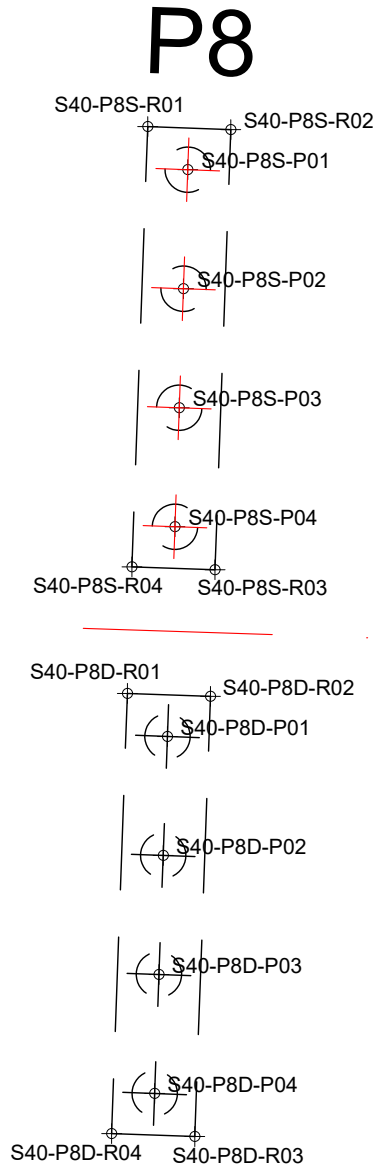

TRASARE RADIER PILA "P9"- fir stanga			
Pct.	Y-(EST)	X-(NORD)	Z
S40-P9S-R01	231740.45	565446.14	90.16
S40-P9S-R02	231739.61	565444.25	90.16
S40-P9S-R03	231729.01	565449.24	90.16
S40-P9S-R04	231729.97	565451.22	90.16

TRASARE PILOTI PILA "P9"- fir stanga				
Pct.	Y-(EST)	X-(NORD)	Zsup	Zinf
S40-P9S-P01	231738.98	565445.63	90.26	68.16
S40-P9S-P02	231736.15	565447.00	90.26	68.16
S40-P9S-P03	231733.32	565448.38	90.26	68.16
S40-P9S-P04	231730.48	565449.75	90.26	68.16

TRASARE RADIER PILA "P9"- fir dreapta			
Pct.	Y-(EST)	X-(NORD)	Z
S40-P9D-R01	231726.96	565452.68	90.26
S40-P9D-R02	231726.00	565450.71	90.26
S40-P9D-R03	231715.52	565455.79	90.26
S40-P9D-R04	231716.48	565457.77	90.26

TRASARE PILOTI PILA "P9"- fir dreapta				
Pct.	Y-(EST)	X-(NORD)	Zsup	Zinf
S40-P9D-P01	231725.49	565452.18	90.36	68.26
S40-P9D-P02	231722.66	565453.55	90.36	68.26
S40-P9D-P03	231719.82	565454.93	90.36	68.26
S40-P9D-P04	231716.99	565456.30	90.36	68.26

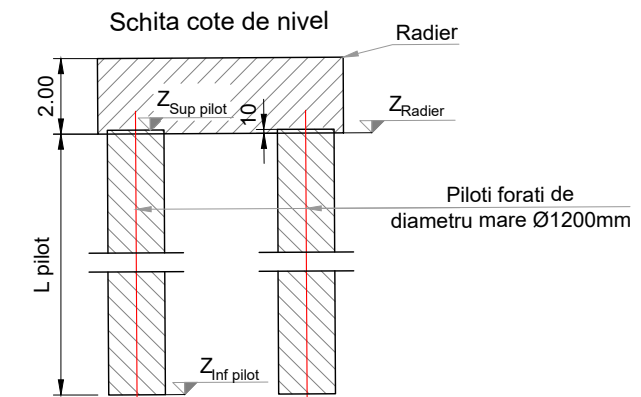
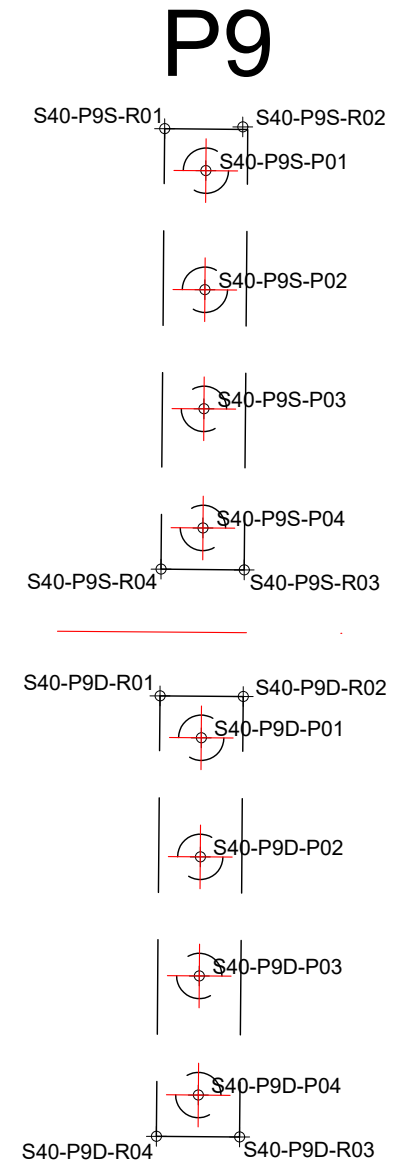

<b>PROIECTANT / DESIGNER:</b> <b>S.C. CONSITRANS S.R.L.</b>	<b>BENEFICIAR / BENEFICIARY:</b> <b>MUNICIPIUL ARAD, MUNICIPIUL ORADEA, CONSILIUL JUDETEAN ARAD, CONSILIUL JUDETEAN BIHOR CNAIR</b>	<b>FUNCTIA / POSITION:</b> <b>COORDONATOR DE PROIECT / PROJECT MANAGER</b>	<b>NUME / NAME:</b> ing. S. VEACESLAV	<b>SEMNATURA / SIGNATURE:</b> 	<b>Titlu plansa / Drawing title:</b> Plan trasare - plan 5 / 12 Layout plan - drawing 5 / 12	<b>REV. / REV.:</b> R00	<b>DATA / DATE:</b> 11.2023	<b>DETALII REVIZIE / REVISION DETAILS:</b> P.T.E.	<b>PROIECTAT / DESIGNER:</b> Consitrans
 UNIUNEA EUROPEANA PROIECT CO-FINANAT DIN FONDUL DE COEZIUNE, PRIN PROGRAMUL OPERATIONAL INFRASTRUCTURA MARE / PROJECT CO-FINANCED FROM THE COHESION FUND, THROUGH THE LARGE INFRASTRUCTURE OPERATIONAL PROGRAM	 GUVERNUL ROMANIEI Instrumente Structurale 2014-2020	<b>FAZA PROIECTARE / DESIGN STAGE:</b> <b>PROIECT TEHNIC DE EXECUTIE / EXECUTION TECHNICAL PROJECT</b>	<b>PROIECTAT / DESIGNER:</b> ing. V. URDAREANU		<b>LUCRARI DE POD / BRIDGE WORKS</b>	<b>Cod plansa / Drawing code:</b> CST-0121-PTE-02-DX- 02-P40-PTR-05-R00			
		<b>Contract /Contract:</b> 14724/01.07.2021 <b>Project /Project no.:</b> 001/2021	<b>Data / Date:</b> 11.2023	<b>Scara /Scale:</b> 1:200					

TRASARE RADIER PILA "P10"- fir stanga			
Pct.	Y-(EST)	X-(NORD)	Z
S40-P10S-R01	231723.79	565410.73	89.86
S40-P10S-R02	231721.66	565406	89.86
S40-P10S-R03	231711.07	565410.77	89.86
S40-P10S-R04	231713.2	565415.5	89.86

TRASARE PILOTI PILA "P10"- fir stanga				
Pct.	Y-(EST)	X-(NORD)	Zsup	Zinf
S40-P10S-P01	231722.35	565410.17	89.96	67.86
S40-P10S-P02	231721.12	565407.44	89.96	67.86
S40-P10S-P03	231719.48	565411.47	89.96	67.86
S40-P10S-P04	231718.25	565408.73	89.96	67.86
S40-P10S-P05	231716.61	565412.76	89.96	67.86
S40-P10S-P06	231715.38	565410.03	89.96	67.86
S40-P10S-P07	231713.73	565414.05	89.96	67.86
S40-P10S-P08	231712.51	565411.33	89.96	67.86

TRASARE RADIER PILA "P10"- fir dreapta			
Pct.	Y-(EST)	X-(NORD)	Z
S40-P10D-R01	231710.11	565416.9	89.96
S40-P10D-R02	231707.99	565412.18	89.96
S40-P10D-R03	231697.41	565416.95	89.96
S40-P10D-R04	231699.55	565421.68	89.96

TRASARE PILOTI PILA "P10"- fir dreapta				
Pct.	Y-(EST)	X-(NORD)	Zsup	Zinf
S40-P10D-P01	231708.68	565416.35	90.06	67.96
S40-P10D-P02	231707.45	565413.61	90.06	67.96
S40-P10D-P03	231705.81	565417.64	90.06	67.96
S40-P10D-P04	231704.58	565414.91	90.06	67.96
S40-P10D-P05	231702.94	565418.94	90.06	67.96
S40-P10D-P06	231701.71	565416.21	90.06	67.96
S40-P10D-P07	231700.07	565420.24	90.06	67.96
S40-P10D-P08	231698.84	565417.5	90.06	67.96

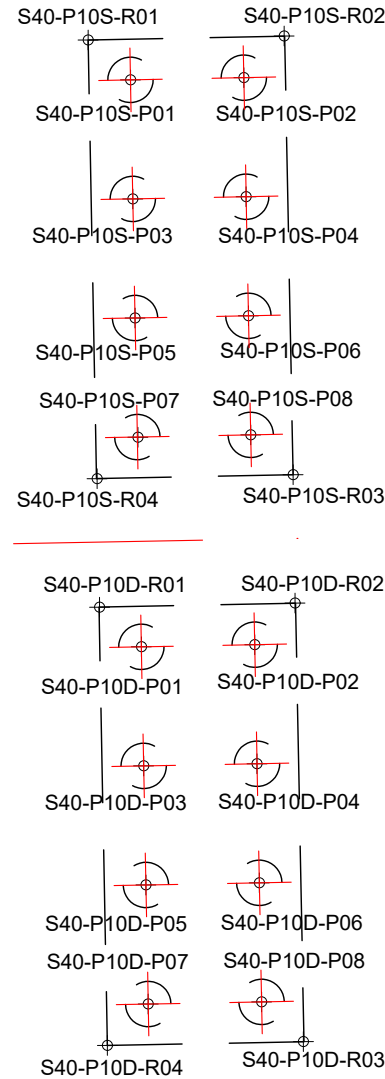
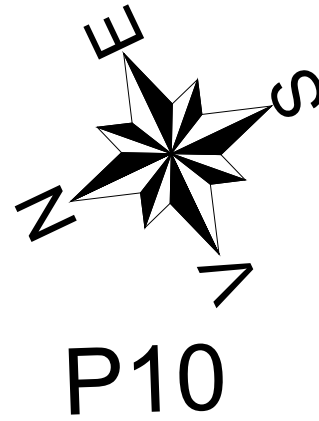





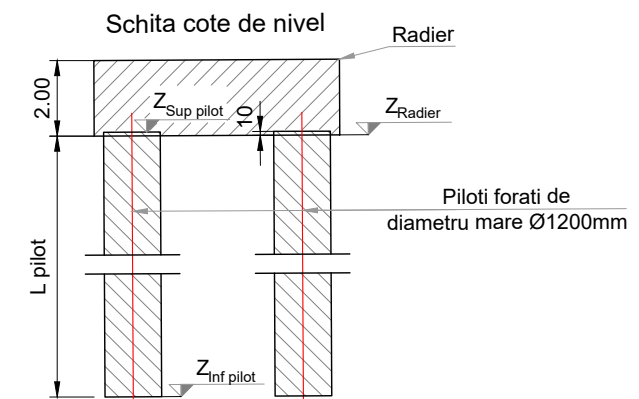

TRASARE RADIER PILA "P11"- fir stanga			
Pct.	Y-(EST)	X-(NORD)	Z
S40-P11S-R01	231706.94	565372.11	89.92
S40-P11S-R02	231706.09	565370.08	89.92
S40-P11S-R03	231695.34	565374.59	89.92
S40-P11S-R04	231696.20	565376.61	89.92

TRASARE PILOTI PILA "P11"- fir stanga				
Pct.	Y-(EST)	X-(NORD)	Zsup	Zinf
S40-P11S-P01	231705.50	565371.52	90.02	67.92
S40-P11S-P02	231702.59	565372.74	90.02	67.92
S40-P11S-P03	231699.69	565373.96	90.02	67.92
S40-P11S-P04	231696.78	565375.17	90.02	67.92

TRASARE RADIER PILA "P11"- fir dreapta			
Pct.	Y-(EST)	X-(NORD)	Z
S40-P11D-R01	231693.11	565377.91	90.02
S40-P11D-R02	231692.26	565375.88	90.02
S40-P11D-R03	231681.51	565380.39	90.02
S40-P11D-R04	231682.36	565382.41	90.02

TRASARE PILOTI PILA "P11"- fir dreapta				
Pct.	Y-(EST)	X-(NORD)	Zsup	Zinf
S40-P11D-P01	231691.67	565377.32	90.12	68.02
S40-P11D-P02	231688.76	565378.54	90.12	68.02
S40-P11D-P03	231685.86	565379.76	90.12	68.02
S40-P11D-P04	231682.95	565380.97	90.12	68.02



<b>PROIECTANT / DESIGNER:</b> <b>S.C. CONSTRANS S.R.L.</b> 	<b>BENEFICIAR / BENEFICIARY:</b> <b>MUNICIPIUL ARAD, MUNICIPIUL ORADEA, CONSILIUL JUDETEAN ARAD, CONSILIUL JUDETEAN BIHOR CNAIR</b>	<b>FUNCTIA / POSITION:</b> <b>COORDONATOR DE PROIECT / PROJECT MANAGER</b> ing. S. VEACESLAV	<b>NUME / NAME:</b> ing. S. VEACESLAV	<b>SEMNTURA / SIGNATURE:</b> 	<b>Titlu plansa / Drawing title:</b> <b>Plan trasare - plan 6 / 12</b> <b>Layout plan - drawing 6 / 12</b>	<b>REV/ REV.:</b> R00	<b>DATA/ DATE:</b> 11.2023	<b>DETALII REVIZIE / REVISION DETAILS:</b> P.T.E.	<b>PROIECTAT / DESIGNER:</b> Constrans
 UNIUNEA EUROPEANA PROIECT CO-FINANTAT DIN FONDUL DE COEZIUNE, PRIN PROGRAMUL OPERATIONAL INFRASTRUCTURA MARE / PROJECT CO-FINANCED FROM THE COHESION FUND, THROUGH THE LARGE INFRASTRUCTURE OPERATIONAL PROGRAM	 GUVERNUL ROMANIEI	 Instrumente Structurale 2014-2020	<b>FAZA PROIECTARE / DESIGN STAGE:</b> <b>PROIECT TEHNIC DE EXECUTIE / EXECUTION TECHNICAL PROJECT</b>	<b>PROIECTAT / DESIGNER:</b> ing. D. COVELTIR	<b>VERIFICAT / INTERNAL CHECKER:</b> ing. D. COVELTIR	<b>Contract /Contract:</b> 14724/01.07.2021 <b>Project /Project no.:</b> 001/2021	<b>Data / Date:</b> 11.2023	<b>Scara /Scale:</b> 1:200	



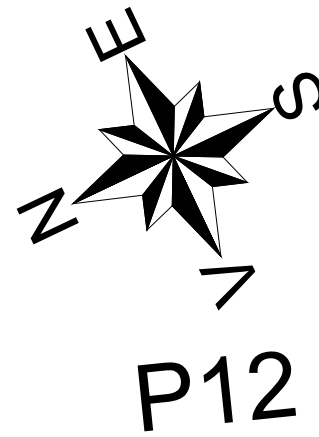

TRASARE RADIER PILA "P12"- fir stanga			
Pct.	Y-(EST)	X-(NORD)	Z
S40-P12S-R01	231691.53	565333.97	90.19
S40-P12S-R02	231690.74	565331.92	90.19
S40-P12S-R03	231679.87	565336.13	90.19
S40-P12S-R04	231680.67	565338.18	90.19

TRASARE PILOTI PILA "P12"- fir stanga				
Pct.	Y-(EST)	X-(NORD)	Zsup	Zinf
S40-P12S-P01	231690.11	565333.35	90.29	68.19
S40-P12S-P02	231687.17	565334.48	90.29	68.19
S40-P12S-P03	231684.23	565335.62	90.29	68.19
S40-P12S-P04	231681.30	565336.76	90.29	68.19

TRASARE RADIER PILA "P12"- fir dreapta			
Pct.	Y-(EST)	X-(NORD)	Z
S40-P12D-R01	231677.54	565339.39	90.29
S40-P12D-R02	231676.75	565337.34	90.29
S40-P12D-R03	231665.89	565341.54	90.29
S40-P12D-R04	231666.68	565343.60	90.29

TRASARE PILOTI PILA "P12"- fir dreapta				
Pct.	Y-(EST)	X-(NORD)	Zsup	Zinf
S40-P12D-P01	231676.12	565338.76	90.39	68.29
S40-P12D-P02	231673.18	565339.90	90.39	68.29
S40-P12D-P03	231670.25	565341.04	90.39	68.29
S40-P12D-P04	231667.31	565342.17	90.39	68.29

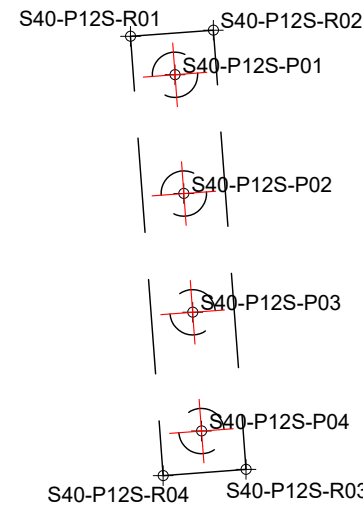

TRASARE RADIER PILA "P13"- fir stanga			
Pct.	Y-(EST)	X-(NORD)	Z
S40-P13S-R01	231677.19	565295.43	90.38
S40-P13S-R02	231676.45	565293.35	90.38
S40-P13S-R03	231665.47	565297.26	90.38
S40-P13S-R04	231666.21	565299.33	90.38

TRASARE PILOTI PILA "P13"- fir stanga				
Pct.	Y-(EST)	X-(NORD)	Zsup	Zinf
S40-P13S-P01	231675.78	565294.76	90.48	68.38
S40-P13S-P02	231672.81	565295.81	90.48	68.38
S40-P13S-P03	231669.85	565296.87	90.48	68.38
S40-P13S-P04	231666.88	565297.93	90.48	68.38

TRASARE RADIER PILA "P13"- fir dreapta			
Pct.	Y-(EST)	X-(NORD)	Z
S40-P13D-R01	231663.05	565300.45	90.48
S40-P13D-R02	231662.32	565298.38	90.48
S40-P13D-R03	231651.34	565302.28	90.48
S40-P13D-R04	231652.08	565304.36	90.48

TRASARE PILOTI PILA "P13"- fir dreapta				
Pct.	Y-(EST)	X-(NORD)	Zsup	Zinf
S40-P13D-P01	231661.65	565299.79	90.58	68.48
S40-P13D-P02	231658.68	565300.84	90.58	68.48
S40-P13D-P03	231655.71	565301.90	90.58	68.48
S40-P13D-P04	231652.74	565302.95	90.58	68.48

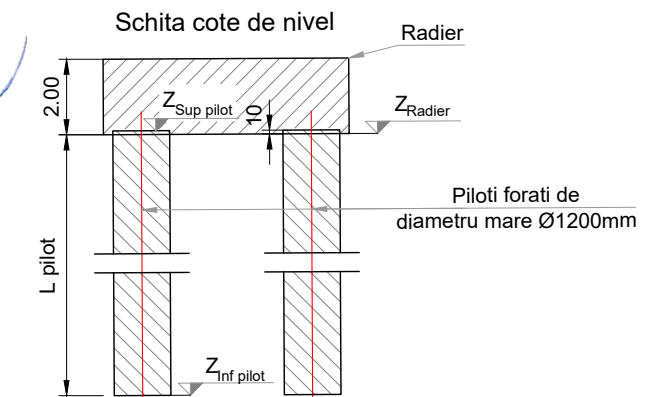
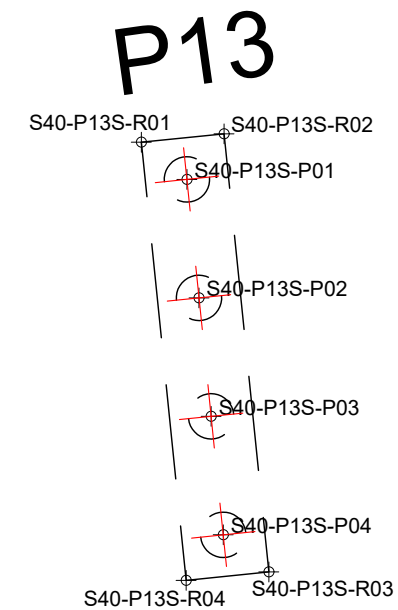

PROIECTANT / DESIGNER:  
S.C. CONSITRANS S.R.L.



BENEFICIAR / BENEFICIARY:  
MUNICIPIUL ARAD, MUNICIPIUL ORADEA, CONSILIUL JUDETEAN ARAD, CONSILIUL JUDETEAN BIHOR CNAIR

FUNCTIA / POSITION:  
COORDONATOR DE PROIECT / PROJECT MANAGER

NUME / NAME:  
ing. S. VEACESLAV

SEMNTURA / SIGNATURE:  
*[Signature]*

Titlu plansa / Drawing title:  
Plan trasare - plan 7 / 12  
Layout plan - drawing 7 / 12

REV. / REV.  
R00

DATA / DATE:  
11.2023

DETALII REVIZIE / REVISION DETAILS:  
P.T.E.

PROIECTAT / DESIGNER:  
Consitrans

INVESTITIA / INVESTMENT:  
ACTUALIZARE/COMPLETARE/REVIZUIRE (S.F. + P.A.C. + P.O.E + P.T.E.) "DRUM EXPRES ARAD ORADEA"  
ACTUALIZATION/COMPLETION (S.F. + P.A.C. + P.O.E + P.T.E.) "EXPRESS ROAD ARAD ORADEA"

SEF PROIECT SPECIALITATE / TEAM LEADER  
ing. D. COVELTIR

SEMNTURA / SIGNATURE:  
*[Signature]*

Pod pe DX la km 71+700 peste raul Crisul Alb  
Bridge on DX at km 71+700 over Crisul Alb river

REV. / REV.

DATA / DATE:

DETALII REVIZIE / REVISION DETAILS:

PROIECTAT / DESIGNER:

FAZA PROIECTARE / DESIGN STAGE:  
PROIECT TEHNIC DE EXECUTIE / EXECUTION TECHNICAL PROJECT

PROIECTAT / DESIGNER:  
ing. V. URDAREANU

SEMNTURA / SIGNATURE:  
*[Signature]*

LUCRARI DE POD / BRIDGE WORKS

REV. / REV.

DATA / DATE:

DETALII REVIZIE / REVISION DETAILS:

PROIECTAT / DESIGNER:

Contract /Contract: 14724/01.07.2021  
Data / Date: 11.2023  
Scara /Scale: 1:200

VERIFICAT / INTERNAL CHECKER:  
ing. D. COVELTIR

SEMNTURA / SIGNATURE:  
*[Signature]*

Cod plansa / Drawing code:  
CST-0121-PTE-02-DX- 02-P40-PTR-07-R00

REV. / REV.

DATA / DATE:

DETALII REVIZIE / REVISION DETAILS:

PROIECTAT / DESIGNER:



PROIECT CO-FINANAT DIN FONDUL DE COEZIUNE, PRIN PROGRAMUL OPERATIONAL INFRASTRUCTURA MARE / PROJECT CO-FINANCED FROM THE COHESION FUND, THROUGH THE LARGE INFRASTRUCTURE OPERATIONAL PROGRAM

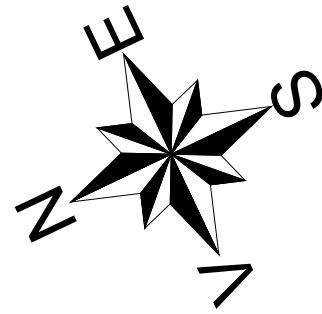

## P14

### TRASARE RADIER PILA "P14"- fir stanga

Pct.	Y-(EST)	X-(NORD)	Z
S40-P14S-R01	231664.58	565258.64	90.01
S40-P14S-R02	231662.82	565253.22	90.01
S40-P14S-R03	231651.79	565256.81	90.01
S40-P14S-R04	231653.55	565262.23	90.01

### TRASARE PILOTI PILA "P14"- fir stanga

Pct.	Y-(EST)	X-(NORD)	Zsup	Zinf
S40-P14S-P01	231663.22	565257.93	90.11	68.01
S40-P14S-P02	231662.14	565254.60	90.11	68.01
S40-P14S-P03	231660.22	565258.90	90.11	68.01
S40-P14S-P04	231659.14	565255.57	90.11	68.01
S40-P14S-P05	231657.23	565259.88	90.11	68.01
S40-P14S-P06	231656.15	565256.55	90.11	68.01
S40-P14S-P07	231654.23	565260.85	90.11	68.01
S40-P14S-P08	231653.15	565257.52	90.11	68.01

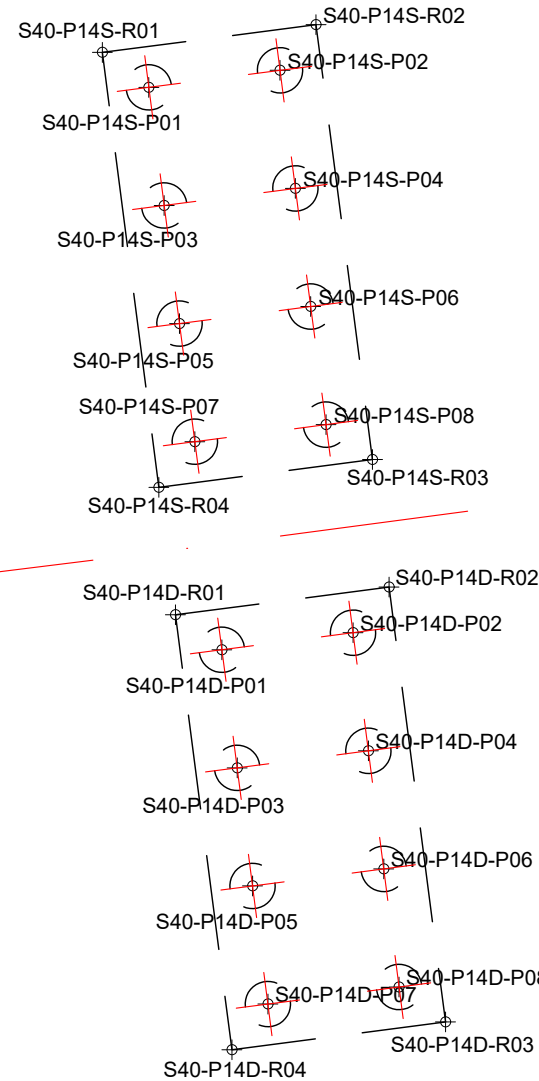

### TRASARE RADIER PILA "P14"- fir dreapta

Pct.	Y-(EST)	X-(NORD)	Z
S40-P14D-R01	231650.32	565263.28	89.88
S40-P14D-R02	231648.56	565257.86	89.88
S40-P14D-R03	231637.52	565261.45	89.88
S40-P14D-R04	231639.29	565266.87	89.88

### TRASARE PILOTI PILA "P14"- fir dreapta

Pct.	Y-(EST)	X-(NORD)	Zsup	Zinf
S40-P14D-P01	231648.96	565262.57	89.98	67.88
S40-P14D-P02	231647.87	565259.24	89.98	67.88
S40-P14D-P03	231645.96	565263.54	89.98	67.88
S40-P14D-P04	231644.88	565260.21	89.98	67.88
S40-P14D-P05	231642.96	565264.51	89.98	67.88
S40-P14D-P06	231641.88	565261.19	89.98	67.88
S40-P14D-P07	231639.97	565265.49	89.98	67.88
S40-P14D-P08	231638.89	565262.16	89.98	67.88

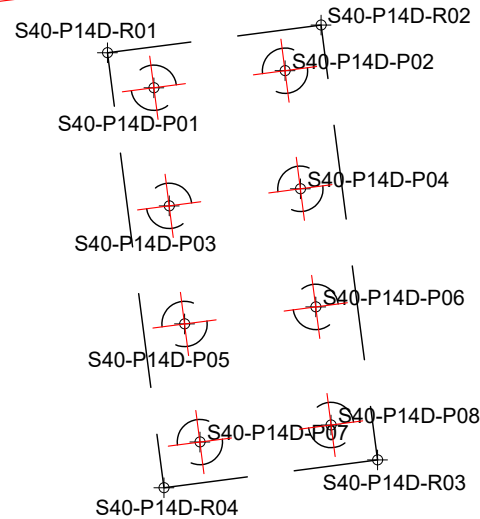

### TRASARE RADIER PILA "P15"- fir stanga

Pct.	Y-(EST)	X-(NORD)	Z
S40-P15S-R01	231645.32	565192.9	90.58
S40-P15S-R02	231642.34	565188.04	90.58
S40-P15S-R03	231632.45	565194.1	90.58
S40-P15S-R04	231635.43	565198.96	90.58

### TRASARE PILOTI PILA "P15"- fir stanga

Pct.	Y-(EST)	X-(NORD)	Zsup	Zinf
S40-P15S-P01	231643.83	565192.52	90.68	68.58
S40-P15S-P02	231642	565189.54	90.68	68.58
S40-P15S-P03	231641.14	565194.17	90.68	68.58
S40-P15S-P04	231639.31	565191.18	90.68	68.58
S40-P15S-P05	231638.46	565195.81	90.68	68.58
S40-P15S-P06	231636.63	565192.83	90.68	68.58
S40-P15S-P07	231635.77	565197.46	90.68	68.58
S40-P15S-P08	231633.94	565194.47	90.68	68.58

### TRASARE RADIER PILA "P15"- fir dreapta





Pct.	Y-(EST)	X-(NORD)	Z
S40-P15D-R01	231632.01	565201.05	90.68
S40-P15D-R02	231629.04	565196.19	90.68
S40-P15D-R03	231619.15	565202.24	90.68
S40-P15D-R04	231622.12	565207.11	90.68

### TRASARE PILOTI PILA "P15"- fir dreapta

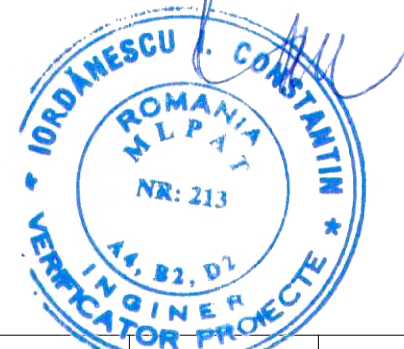
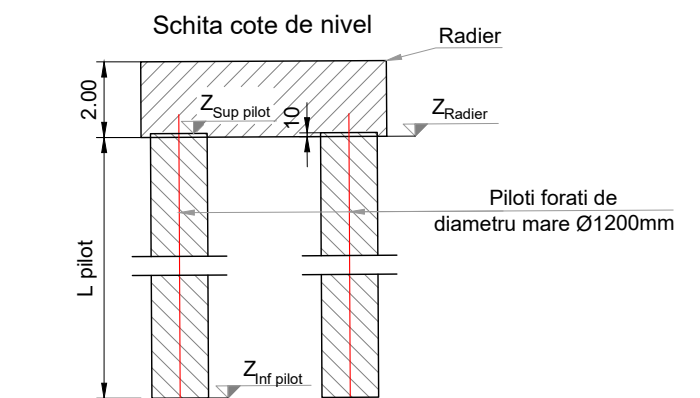
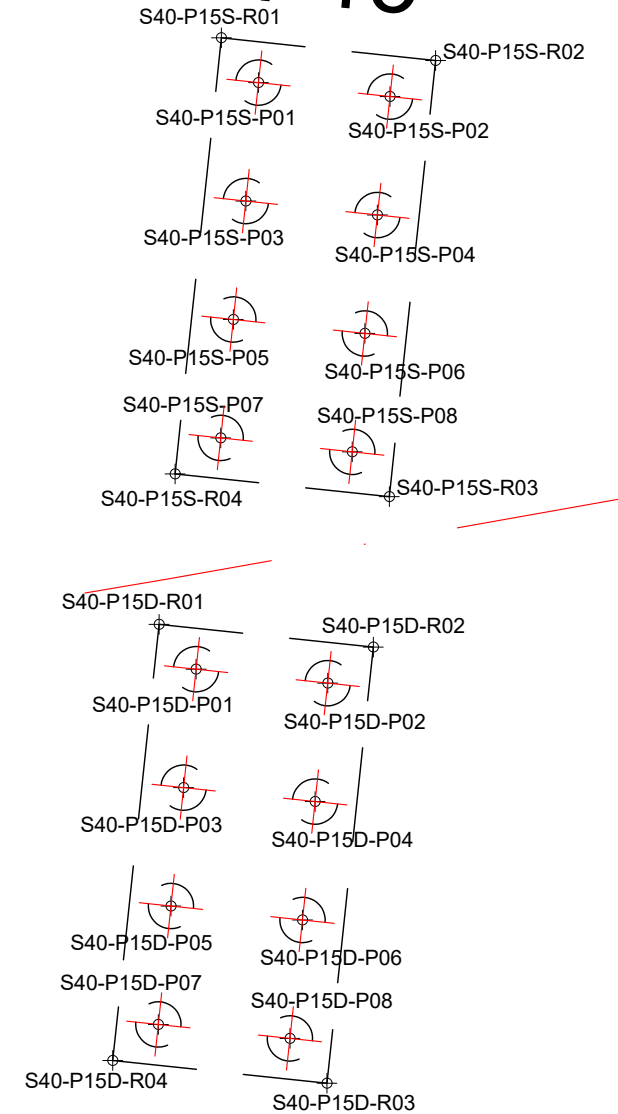
Pct.	Y-(EST)	X-(NORD)	Zsup	Zinf
S40-P15D-P01	231630.52	565200.67	90.78	68.68
S40-P15D-P02	231628.7	565197.69	90.78	68.68
S40-P15D-P03	231627.84	565202.32	90.78	68.68
S40-P15D-P04	231626.01	565199.33	90.78	68.68
S40-P15D-P05	231625.15	565203.96	90.78	68.68
S40-P15D-P06	231623.32	565200.98	90.78	68.68
S40-P15D-P07	231622.46	565205.61	90.78	68.68
S40-P15D-P08	231620.64	565202.62	90.78	68.68

## P15



<b>PROIECTANT / DESIGNER:</b> <b>S.C. CONSITRANS S.R.L.</b> 	<b>BENEFICIAR / BENEFICIARY:</b> <b>MUNICIPIUL ARAD, MUNICIPIUL ORADEA, CONSILIUL JUDETEAN ARAD, CONSILIUL JUDETEAN BIHOR CNAIR</b>		<b>FUNCTIA / POSITION:</b> <b>COORDONATOR DE PROIECT / PROJECT MANAGER</b>	<b>NUME / NAME:</b> ing. S. VEACESLAV	<b>SEMNATURA / SIGNATURE:</b> 	<b>Titlu plansa / Drawing title:</b> <b>Plan trasare - plan 8 / 12</b> <b>Layout plan - drawing 8 / 12</b>	<b>REV. / REV.:</b> R00	<b>DATA / DATE:</b> 11.2023	<b>DETALII REVIZIE / REVISION DETAILS:</b> P.T.E.	<b>PROIECTAT / DESIGNER:</b> Consitrans
	<b>INVESTITIA / INVESTMENT:</b> <b>ACTUALIZARE/COMPLETARE/REVIZUIRE (S.F. + P.A.C. + P.O.E + P.T.E.) "DRUM EXPRES ARAD ORADEA"</b> <b>ACTUALIZATION/COMPLETION (S.F. + P.A.C. + P.O.E + P.T.E.) "EXPRESS ROAD ARAD ORADEA"</b>		<b>SEF PROIECT SPECIALITATE / TEAM LEADER</b> ing. D. COVELTIR		Pod pe DX la km 71+700 peste raul Crisul Alb Bridge on DX at km 71+700 over Crisul Alb river		<b>LUCRARI DE POD / BRIDGE WORKS</b>	<b>Cod plansa / Drawing code:</b> CST-0121-PTE-02-DX- 02-P40-PTR-08-R00		
<b>FAZA PROIECTARE / DESIGN STAGE:</b> <b>PROIECT TEHNIC DE EXECUTIE / EXECUTION TECHNICAL PROJECT</b>		<b>PROIECTAT / DESIGNER:</b> ing. V. URDAREANU								
<b>Contract /Contract:</b> 14724/01.07.2021 <b>Project /Project no.:</b> 001/2021		<b>Data /Date:</b> 11.2023	<b>Scara /Scale:</b> 1:200	<b>VERIFICAT / INTERNAL CHECKER:</b> ing. D. COVELTIR						



PROIECT CO-FINANȚAT DIN FONDUL DE COEZIUNE, PRIN PROGRAMUL OPERAȚIONAL INFRASTRUCTURĂ MARE / PROJECT CO-FINANCED FROM THE COHESION FUND, THROUGH THE LARGE INFRASTRUCTURE OPERATIONAL PROGRAM



TRASARE RADIER PILA "P16"- fir stanga			
Pct.	Y-(EST)	X-(NORD)	Z
S40-P16S-R01	231625.47	565111.05	90.31
S40-P16S-R02	231621.61	565104.74	90.31
S40-P16S-R03	231611.72	565110.8	90.31
S40-P16S-R04	231615.58	565117.11	90.31

TRASARE PILOTI PILA "P16"- fir stanga				
Pct.	Y-(EST)	X-(NORD)	Zsup	Zinf
S40-P16S-P01	231623.98	565110.67	90.41	63.31
S40-P16S-P02	231621.27	565106.24	90.41	63.31
S40-P16S-P03	231621.28	565109.28	90.41	63.31
S40-P16S-P04	231621.29	565112.32	90.41	63.31
S40-P16S-P05	231618.58	565107.88	90.41	63.31
S40-P16S-P06	231618.59	565110.92	90.41	63.31
S40-P16S-P07	231618.61	565113.96	90.41	63.31
S40-P16S-P08	231615.89	565109.53	90.41	63.31
S40-P16S-P09	231615.91	565112.57	90.41	63.31
S40-P16S-P10	231615.92	565115.61	90.41	63.31
S40-P16S-P11	231613.21	565111.17	90.41	63.31

TRASARE RADIER PILA "P16"- fir dreapta			
Pct.	Y-(EST)	X-(NORD)	Z
S40-P16D-R01	231611.93	565119.34	89.41
S40-P16D-R02	231608.06	565113.03	89.41
S40-P16D-R03	231598.17	565119.09	89.41
S40-P16D-R04	231602.03	565125.4	89.41

TRASARE PILOTI PILA "P16"- fir dreapta				
Pct.	Y-(EST)	X-(NORD)	Zsup	Zinf
S40-P16D-P01	231610.44	565118.97	89.51	62.41
S40-P16D-P02	231607.72	565114.53	89.51	62.41
S40-P16D-P03	231607.73	565117.57	89.51	62.41
S40-P16D-P04	231607.75	565120.61	89.51	62.41
S40-P16D-P05	231605.03	565116.18	89.51	62.41
S40-P16D-P06	231605.05	565119.22	89.51	62.41
S40-P16D-P07	231605.06	565122.26	89.51	62.41
S40-P16D-P08	231602.35	565117.82	89.51	62.41
S40-P16D-P09	231602.36	565120.86	89.51	62.41
S40-P16D-P10	231602.38	565123.9	89.51	62.41
S40-P16D-P11	231599.66	565119.47	89.51	62.41

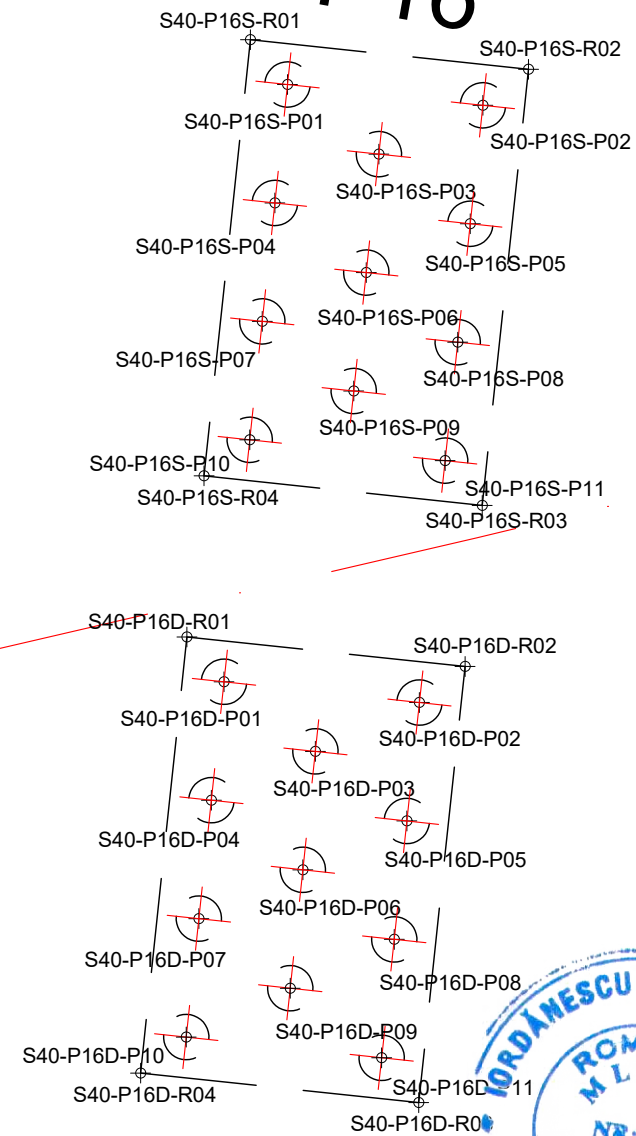
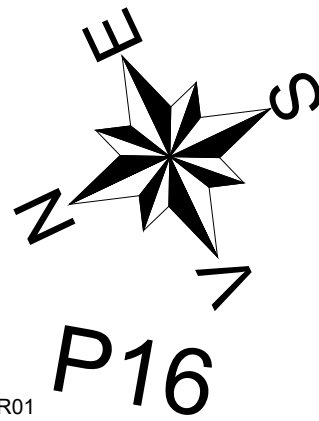





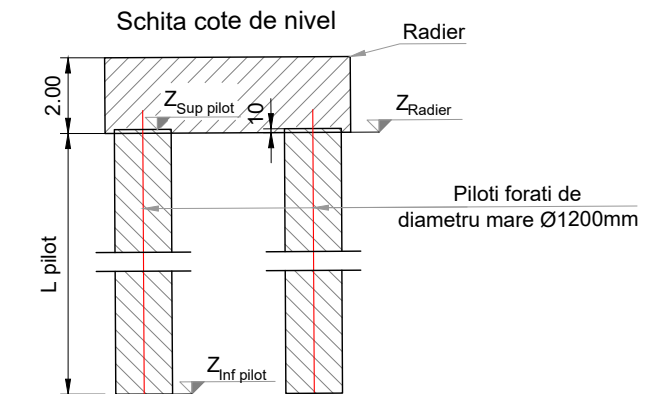
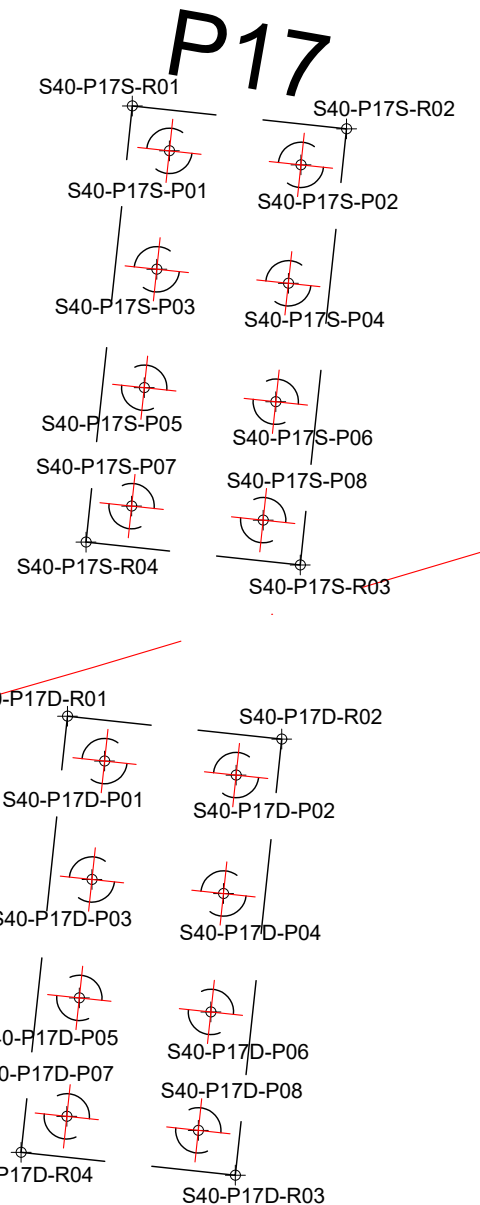

TRASARE RADIER PILA "P17"- fir stanga			
Pct.	Y-(EST)	X-(NORD)	Z
S40-P17S-R01	231609.47	565026.71	91.21
S40-P17S-R02	231606.49	565021.85	91.21
S40-P17S-R03	231596.6	565027.91	91.21
S40-P17S-R04	231599.58	565032.77	91.21

TRASARE PILOTI PILA "P17"- fir stanga				
Pct.	Y-(EST)	X-(NORD)	Zsup	Zinf
S40-P17S-P01	231607.98	565026.33	91.31	64.21
S40-P17S-P02	231606.15	565023.35	91.31	64.21
S40-P17S-P03	231605.29	565027.98	91.31	64.21
S40-P17S-P04	231603.46	565024.99	91.31	64.21
S40-P17S-P05	231602.61	565029.62	91.31	64.21
S40-P17S-P06	231600.78	565026.64	91.31	64.21
S40-P17S-P07	231599.92	565031.27	91.31	64.21
S40-P17S-P08	231598.09	565028.28	91.31	64.21

TRASARE RADIER PILA "P17"- fir dreapta			
Pct.	Y-(EST)	X-(NORD)	Z
S40-P17D-R01	231595.63	565035.18	91.31
S40-P17D-R02	231592.65	565030.32	91.31
S40-P17D-R03	231582.76	565036.38	91.31
S40-P17D-R04	231585.74	565041.24	91.31

TRASARE PILOTI PILA "P17"- fir dreapta				
Pct.	Y-(EST)	X-(NORD)	Zsup	Zinf
S40-P17D-P01	231594.14	565034.81	91.41	64.31
S40-P17D-P02	231592.31	565031.82	91.41	64.31
S40-P17D-P03	231591.45	565036.45	91.41	64.31
S40-P17D-P04	231589.62	565033.47	91.41	64.31
S40-P17D-P05	231588.76	565038.1	91.41	64.31
S40-P17D-P06	231586.94	565035.11	91.41	64.31
S40-P17D-P07	231586.08	565039.74	91.41	64.31
S40-P17D-P08	231584.25	565036.76	91.41	64.31



<b>PROIECTANT / DESIGNER:</b> <b>S.C. CONSITRANS S.R.L.</b> 	<b>BENEFICIAR / BENEFICIARY:</b> <b>MUNICIPIUL ARAD, MUNICIPIUL ORADEA, CONSILIUL JUDETEAN ARAD, CONSILIUL JUDETEAN BIHOR CNAIR</b>		<b>FUNCTIA / POSITION:</b> <b>COORDONATOR DE PROIECT / PROJECT MANAGER</b>	<b>NUME / NAME:</b> ing. S. VEACESLAV	<b>SEMNATURA / SIGNATURE:</b> 	<b>Titlu plansa / Drawing title:</b> <b>Plan trasare - plan 9 / 12</b> <b>Layout plan - drawing 9 / 12</b>	<b>REV. / REV.:</b> R00	<b>DATA / DATE:</b> 11.2023	<b>DETALII REVIZIE / REVISION DETAILS:</b> P.T.E.	<b>PROIECTAT / DESIGNER:</b> Consitrans
	<b>INVESTITIA / INVESTMENT:</b> <b>ACTUALIZARE/COMPLETARE/REVIZUIRE (S.F. + P.A.C. + P.O.E + P.T.E.) "DRUM EXPRES ARAD ORADEA"</b> <b>ACTUALIZATION/COMPLETION (S.F. + P.A.C. + P.O.E + P.T.E.) "EXPRESS ROAD ARAD ORADEA"</b>		<b>SEF PROIECT SPECIALITATE / TEAM LEADER</b> ing. D. COVELTIR	<b>SEMNATURA / SIGNATURE:</b> 	<b>Pod pe DX la km 71+700 peste raul Crisul Alb</b> <b>Bridge on DX at km 71+700 over Crisul Alb river</b>	<b>LUCRARI DE POD / BRIDGE WORKS</b>	<b>Cod plansa / Drawing code:</b> CST-0121-PTE-02-DX- 02-P40-PTR-09-R00			
<b>FAZA PROIECTARE / DESIGN STAGE:</b> <b>PROIECT TEHNIC DE EXECUTIE / EXECUTION TECHNICAL PROJECT</b>		<b>PROIECTAT / DESIGNER:</b> ing. V. URDAREANU	<b>SEMNATURA / SIGNATURE:</b> 	<b>VERIFICAT / INTERNAL CHECKER:</b> ing. D. COVELTIR	<b>SEMNATURA / SIGNATURE:</b> 					
<b>Contract /Contract:</b> 14724/01.07.2021 <b>Project /Project no.:</b> 001/2021		<b>Data / Date:</b> 11.2023	<b>Scara /Scale:</b> 1:200							

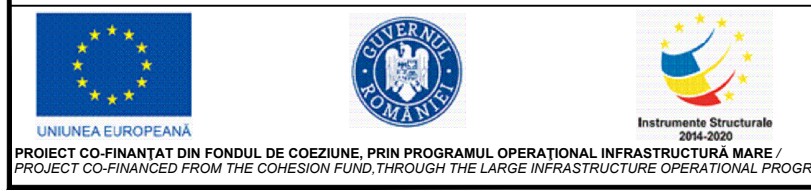

TRASARE RADIER PILA "P18"- fir stanga			
Pct.	Y-(EST)	X-(NORD)	Z
S40-P18S-R01	231600.82	564968.22	91.53
S40-P18S-R02	231600.17	564962.56	91.53
S40-P18S-R03	231588.64	564963.88	91.53
S40-P18S-R04	231589.29	564969.54	91.53

TRASARE PILOTI PILA "P18"- fir stanga				
Pct.	Y-(EST)	X-(NORD)	Zsup	Zinf
S40-P18S-P01	231599.62	564967.25	91.63	64.53
S40-P18S-P02	231599.22	564963.77	91.63	64.53
S40-P18S-P03	231596.49	564967.61	91.63	64.53
S40-P18S-P04	231596.09	564964.13	91.63	64.53
S40-P18S-P05	231593.36	564967.97	91.63	64.53
S40-P18S-P06	231592.97	564964.49	91.63	64.53
S40-P18S-P07	231590.23	564968.33	91.63	64.53
S40-P18S-P08	231589.84	564964.85	91.63	64.53

TRASARE RADIER PILA "P18"- fir dreapta			
Pct.	Y-(EST)	X-(NORD)	Z
S40-P18D-R01	231585.91	564969.93	91.13
S40-P18D-R02	231585.26	564964.26	91.13
S40-P18D-R03	231573.74	564965.58	91.13
S40-P18D-R04	231574.39	564971.25	91.13

TRASARE PILOTI PILA "P18"- fir dreapta				
Pct.	Y-(EST)	X-(NORD)	Zsup	Zinf
S40-P18D-P01	231584.72	564968.96	91.23	64.13
S40-P18D-P02	231584.32	564965.48	91.23	64.13
S40-P18D-P03	231581.59	564969.32	91.23	64.13
S40-P18D-P04	231581.19	564965.84	91.23	64.13
S40-P18D-P05	231578.46	564969.67	91.23	64.13
S40-P18D-P06	231578.06	564966.20	91.23	64.13
S40-P18D-P07	231575.33	564970.03	91.23	64.13
S40-P18D-P08	231574.93	564966.56	91.23	64.13

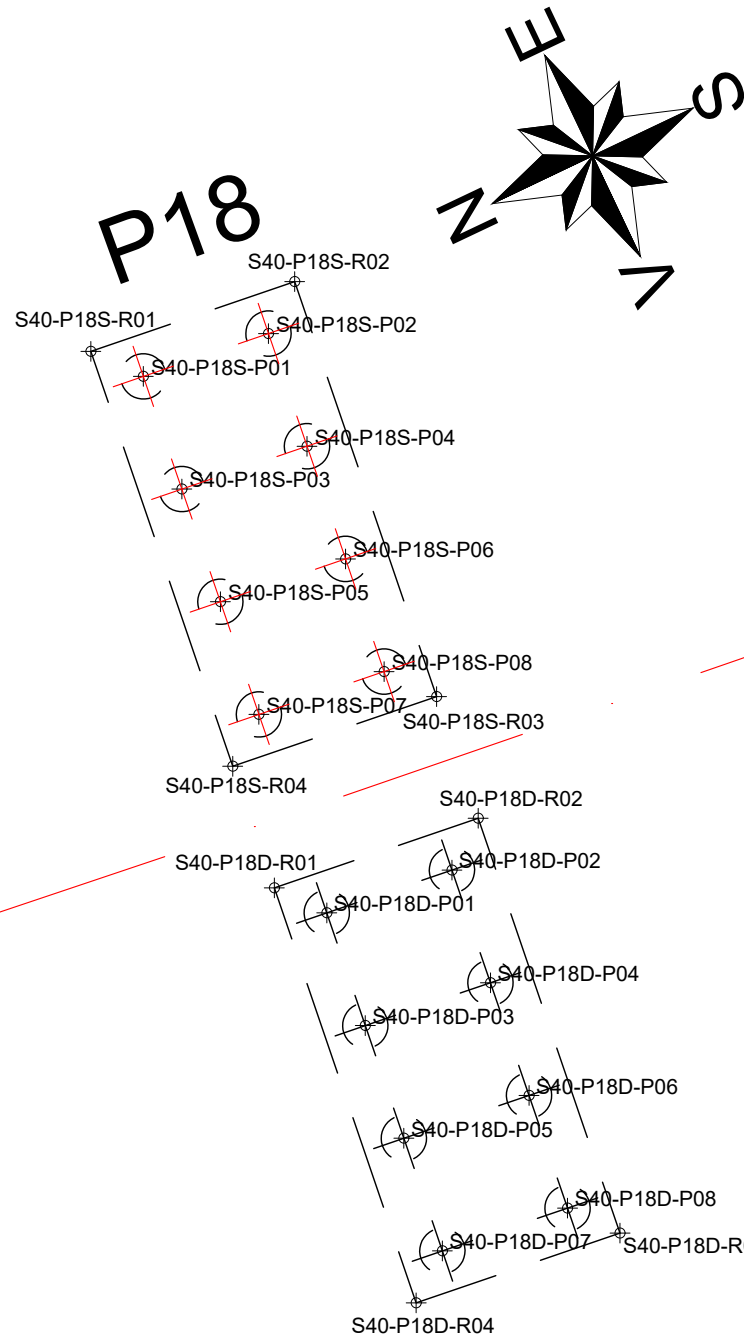

TRASARE RADIER PILA "P19"- fir stanga			
Pct.	Y-(EST)	X-(NORD)	Z
S40-P19S-R01	231596.54	564926.05	91.43
S40-P19S-R02	231596.35	564923.86	91.43
S40-P19S-R03	231584.74	564924.87	91.43
S40-P19S-R04	231584.93	564927.06	91.43

TRASARE PILOTI PILA "P19"- fir stanga				
Pct.	Y-(EST)	X-(NORD)	Zsup	Zinf
S40-P19S-P01	231595.35	564925.05	91.53	64.43
S40-P19S-P02	231592.21	564925.32	91.53	64.43
S40-P19S-P03	231589.07	564925.60	91.53	64.43
S40-P19S-P04	231585.93	564925.87	91.53	64.43

TRASARE RADIER PILA "P19"- fir dreapta			
Pct.	Y-(EST)	X-(NORD)	Z
S40-P19D-R01	231581.60	564927.35	91.03
S40-P19D-R02	231581.41	564925.16	91.03
S40-P19D-R03	231569.80	564926.17	91.03
S40-P19D-R04	231569.99	564928.36	91.03

TRASARE PILOTI PILA "P19"- fir dreapta				
Pct.	Y-(EST)	X-(NORD)	Zsup	Zinf
S40-P19D-P01	231580.40	564926.35	91.13	64.03
S40-P19D-P02	231577.27	564926.62	91.13	64.03
S40-P19D-P03	231574.13	564926.90	91.13	64.03
S40-P19D-P04	231570.99	564927.17	91.13	64.03

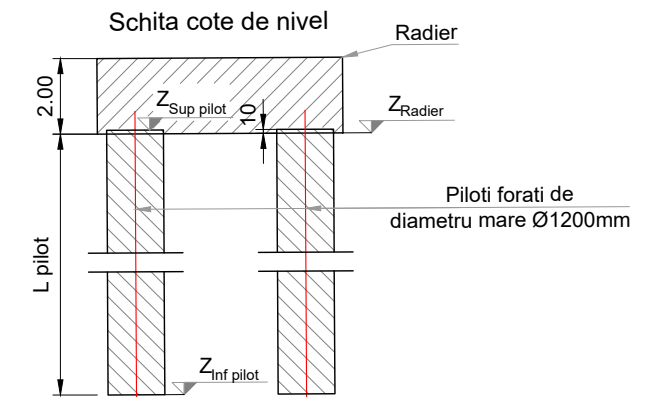
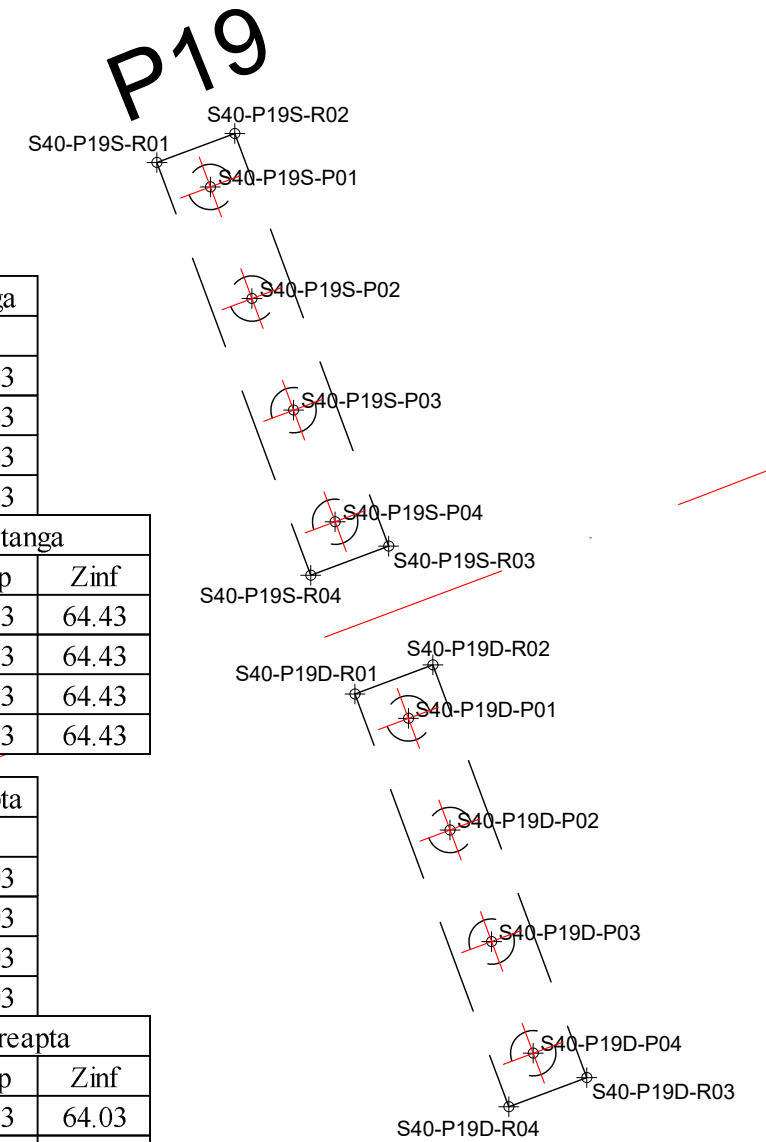

<b>PROIECTANT / DESIGNER:</b> <b>S.C. CONSITRANS S.R.L.</b>		<b>BENEFICIAR / BENEFICIARY:</b> MUNICIPIUL ARAD, MUNICIPIUL ORADEA, CONSILIUL JUDETEAN ARAD, CONSILIUL JUDETEAN BIHOR CNAIR	<b>FUNCTIA / POSITION:</b> COORDONATOR DE PROIECT / PROJECT MANAGER	<b>NUME / NAME:</b> ing. S. VEACESLAV	<b>SEMNTURA / SIGNATURE:</b> 	<b>Titlu plansa / Drawing title:</b> Plan trasare - plan 10 / 12 Layout plan - drawing 10 / 12	<b>REV. / REV.:</b> R00	<b>DATA / DATE:</b> 11.2023	<b>DETALII REVIZIE / REVISION DETAILS:</b> P.T.E.	<b>PROIECTAT / DESIGNER:</b> Consitrans
		<b>INVESTITIA / INVESTMENT:</b> ACTUALIZARE/COMPLETARE/REVIZUIRE (S.F. + P.A.C. + P.O.E + P.T.E.) "DRUM EXPRES ARAD ORADEA" ACTUALIZATION/COMPLETION (S.F. + P.A.C. + P.O.E + P.T.E.) "EXPRESS ROAD ARAD ORADEA"	<b>SEF PROIECT SPECIALITATE / TEAM LEADER:</b> ing. D. COVELTIR		Pod pe DX la km 71+700 peste raul Crisul Alb Bridge on DX at km 71+700 over Crisul Alb river					
		<b>FAZA PROIECTARE / DESIGN STAGE:</b> <b>PROIECT TEHNIC DE EXECUTIE / EXECUTION TECHNICAL PROJECT</b>	<b>PROIECTAT / DESIGNER:</b> ing. V. URDAREANU		<b>LUCRARI DE POD / BRIDGE WORKS</b>					
UNIUNEA EUROPEANA PROIECT CO-FINANAT DIN FONDUL DE COEZIUNE, PRIN PROGRAMUL OPERATIONAL INFRASTRUCTURA MARE / PROJECT CO-FINANCED FROM THE COHESION FUND, THROUGH THE LARGE INFRASTRUCTURE OPERATIONAL PROGRAM		<b>Contract /Contract:</b> 14724/01.07.2021 <b>Project /Project no.:</b> 001/2021	<b>Data / Date:</b> 11.2023	<b>Scara /Scale:</b> 1:200	<b>VERIFICAT / INTERNAL CHECKER:</b> ing. D. COVELTIR		<b>Cod plansa / Drawing code:</b> CST-0121-PTE-02-DX- 02-P40-PTR-10-R00			



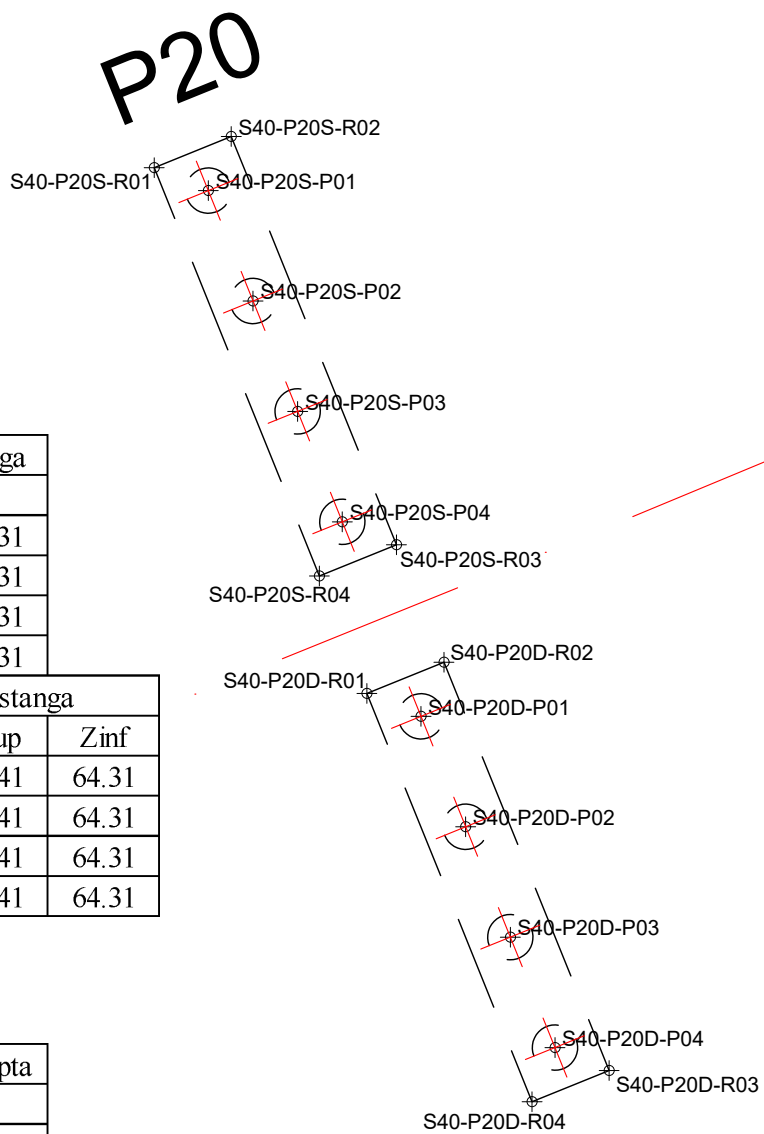
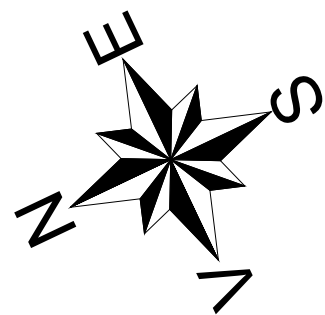

**TRASARE RADIER PILA "P20"- fir stanga**

Pct.	Y-(EST)	X-(NORD)	Z
S40-P20S-R01	231593.51	564885.03	91.31
S40-P20S-R02	231593.38	564882.84	91.31
S40-P20S-R03	231581.75	564883.53	91.31
S40-P20S-R04	231581.88	564885.72	91.31

**TRASARE PILOTI PILA "P20"- fir stanga**

Pct.	Y-(EST)	X-(NORD)	Zsup	Zinf
S40-P20S-P01	231592.35	564884.00	91.41	64.31
S40-P20S-P02	231589.21	564884.19	91.41	64.31
S40-P20S-P03	231586.06	564884.37	91.41	64.31
S40-P20S-P04	231582.92	564884.56	91.41	64.31

**TRASARE RADIER PILA "P20"- fir dreapta**

Pct.	Y-(EST)	X-(NORD)	Z
S40-P20D-R01	231578.54	564885.92	91.41
S40-P20D-R02	231578.41	564883.72	91.41
S40-P20D-R03	231566.78	564884.41	91.41
S40-P20D-R04	231566.91	564886.61	91.41

**TRASARE PILOTI PILA "P20"- fir dreapta**

Pct.	Y-(EST)	X-(NORD)	Zsup	Zinf
S40-P20D-P01	231577.38	564884.89	91.51	64.41
S40-P20D-P02	231574.23	564885.07	91.51	64.41
S40-P20D-P03	231571.09	564885.26	91.51	64.41
S40-P20D-P04	231567.94	564885.44	91.51	64.41



**TRASARE RADIER PILA "P21"- fir stanga**

Pct.	Y-(EST)	X-(NORD)	Z
S40-P21S-R01	231591.66	564845.94	91.40
S40-P21S-R02	231591.5	564840.75	91.40
S40-P21S-R03	231579.9	564841.11	91.40
S40-P21S-R04	231580.07	564846.31	91.40

**TRASARE PILOTI PILA "P21"- fir stanga**

Pct.	Y-(EST)	X-(NORD)	Zsup	Zinf
S40-P21S-P01	231590.55	564844.88	91.50	64.40
S40-P21S-P02	231590.46	564841.88	91.50	64.40
S40-P21S-P03	231587.41	564844.98	91.50	64.40
S40-P21S-P04	231587.31	564841.98	91.50	64.40
S40-P21S-P05	231584.26	564845.08	91.50	64.40
S40-P21S-P06	231584.16	564842.08	91.50	64.40
S40-P21S-P07	231581.11	564845.18	91.50	64.40
S40-P21S-P08	231581.01	564842.18	91.50	64.40

**TRASARE RADIER PILA "P21"- fir dreapta**

Pct.	Y-(EST)	X-(NORD)	Z
S40-P21D-R01	231576.67	564846.42	91.00
S40-P21D-R02	231576.51	564841.22	91.00
S40-P21D-R03	231564.91	564841.59	91.00
S40-P21D-R04	231565.08	564846.79	91.00

**TRASARE PILOTI PILA "P21"- fir dreapta**

Pct.	Y-(EST)	X-(NORD)	Zsup	Zinf
S40-P21D-P01	231575.56	564845.35	91.10	64.00
S40-P21D-P02	231575.47	564842.35	91.10	64.00
S40-P21D-P03	231572.41	564845.45	91.10	64.00
S40-P21D-P04	231572.32	564842.45	91.10	64.00
S40-P21D-P05	231569.26	564845.55	91.10	64.00
S40-P21D-P06	231569.17	564842.55	91.10	64.00
S40-P21D-P07	231566.12	564845.65	91.10	64.00
S40-P21D-P08	231566.02	564842.65	91.10	64.00

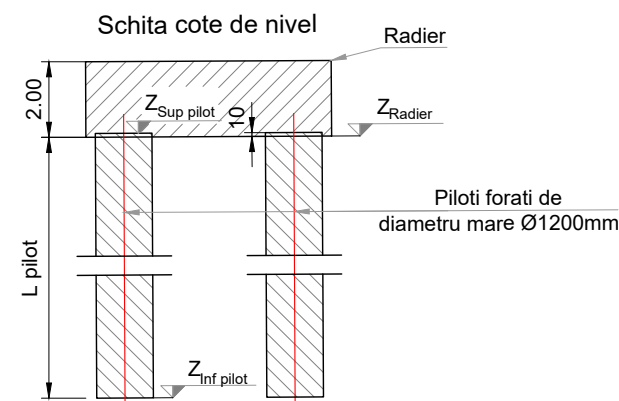
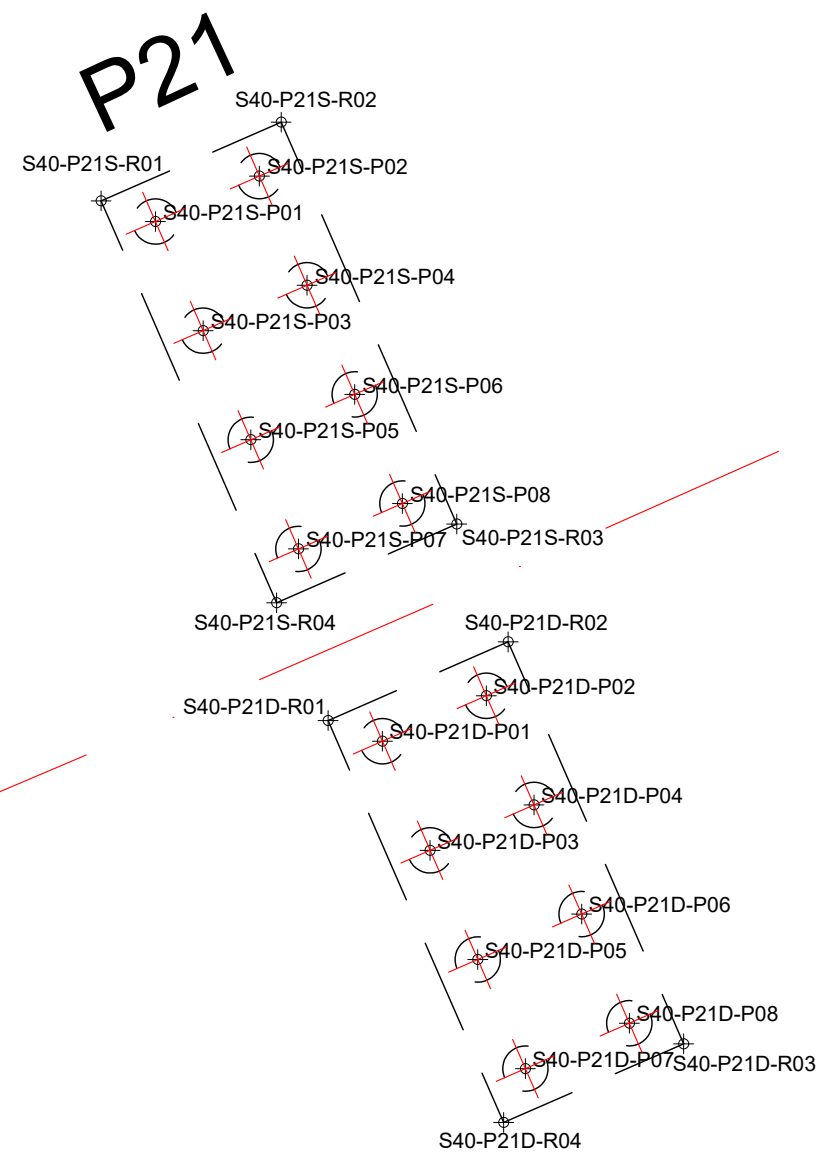

<b>PROIECTANT / DESIGNER:</b> <b>S.C. CONSTRANS S.R.L.</b>	<b>BENEFICIAR / BENEFICIARY:</b> <b>MUNICIPIUL ARAD, MUNICIPIUL ORADEA, CONSILIUL JUDETEAN ARAD, CONSILIUL JUDETEAN BIHOR CNAIR</b>	<b>FUNCTIA / POSITION:</b> <b>COORDONATOR DE PROIECT / PROJECT MANAGER</b>	<b>NUME / NAME:</b> ing. S. VEACESLAV	<b>SEMNATURA / SIGNATURE:</b> 	<b>Titlu plansa / Drawing title:</b> Plan trasare - plan 11 / 12 Layout plan - drawing 11 / 12 Pod pe DX la km 71+700 peste raul Crisul Alb Bridge on DX at km 71+700 over Crisul Alb river	<b>REV. / REV.:</b> R00	<b>DATA / DATE:</b> 11.2023	<b>DETALII REVIZIE / REVISION DETAILS:</b> P.T.E.	<b>PROIECTAT / DESIGNER:</b> Consitrans
		<b>INVESTITIA / INVESTMENT:</b> ACTUALIZARE/COMPLETARE/REVIZUIRE (S.F. + P.A.C. + P.O.E + P.T.E.) "DRUM EXPRES ARAD ORADEA" ACTUALIZATION/COMPLETION (S.F. + P.A.C. + P.O.E + P.T.E.) "EXPRESS ROAD ARAD ORADEA"	<b>SEF PROIECT SPECIALITATE / TEAM LEADER</b> ing. D. COVELTIR						
PROIECT CO-FINANAT DIN FONDUL DE COEZIUNE, PRIN PROGRAMUL OPERATIONAL INFRASTRUCTURA MARE / PROJECT CO-FINANCED FROM THE COHESION FUND, THROUGH THE LARGE INFRASTRUCTURE OPERATIONAL PROGRAM	<b>FAZA PROIECTARE / DESIGN STAGE:</b> <b>PROIECT TEHNIC DE EXECUTIE / EXECUTION TECHNICAL PROJECT</b>	<b>PROIECTAT / DESIGNER:</b> ing. V. URDAREANU		<b>LUCRARI DE POD / BRIDGE WORKS</b>	<b>Cod plansa / Drawing code:</b> CST-0121-PTE-02-DX- 02-P40-PTR-11-R00				
	<b>Contract /Contract:</b> 14724/01.07.2021 <b>Project /Project no.:</b> 001/2021	<b>Data /Date:</b> 11.2023	<b>Scara /Scale:</b> 1:200						<b>VERIFICAT / INTERNAL CHECKER:</b> ing. D. COVELTIR

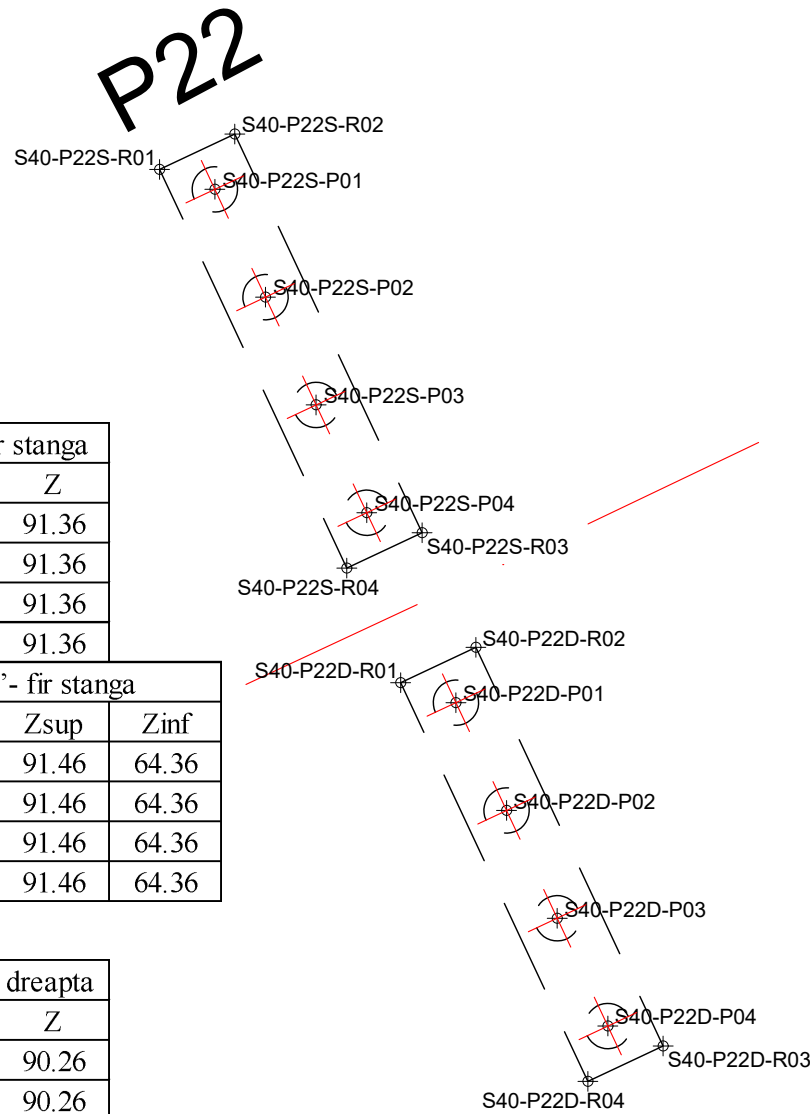
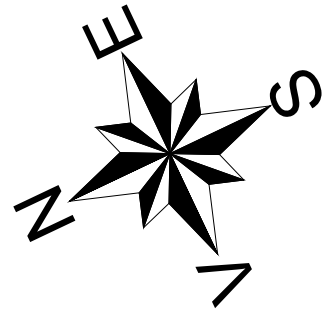

TRASARE RADIER PILA "P22"- fir stanga

Pct.	Y-(EST)	X-(NORD)	Z
S40-P22S-R01	231590.88	564803.82	91.36
S40-P22S-R02	231590.87	564801.62	91.36
S40-P22S-R03	231579.22	564801.67	91.36
S40-P22S-R04	231579.23	564803.87	91.36

TRASARE PILOTI PILA "P22"- fir stanga

Pct.	Y-(EST)	X-(NORD)	Zsup	Zinf
S40-P22S-P01	231589.77	564802.72	91.46	64.36
S40-P22S-P02	231586.62	564802.73	91.46	64.36
S40-P22S-P03	231583.47	564802.75	91.46	64.36
S40-P22S-P04	231580.32	564802.76	91.46	64.36

TRASARE RADIER PILA "P22"- fir dreapta

Pct.	Y-(EST)	X-(NORD)	Z
S40-P22D-R01	231575.88	564803.88	90.26
S40-P22D-R02	231575.87	564801.68	90.26
S40-P22D-R03	231564.22	564801.73	90.26
S40-P22D-R04	231564.23	564803.93	90.26

TRASARE PILOTI PILA "P22"- fir dreapta

Pct.	Y-(EST)	X-(NORD)	Zsup	Zinf
S40-P22D-P01	231574.77	564802.79	90.36	63.26
S40-P22D-P02	231571.62	564802.80	90.36	63.26
S40-P22D-P03	231568.47	564802.81	90.36	63.26
S40-P22D-P04	231565.32	564802.83	90.36	63.26

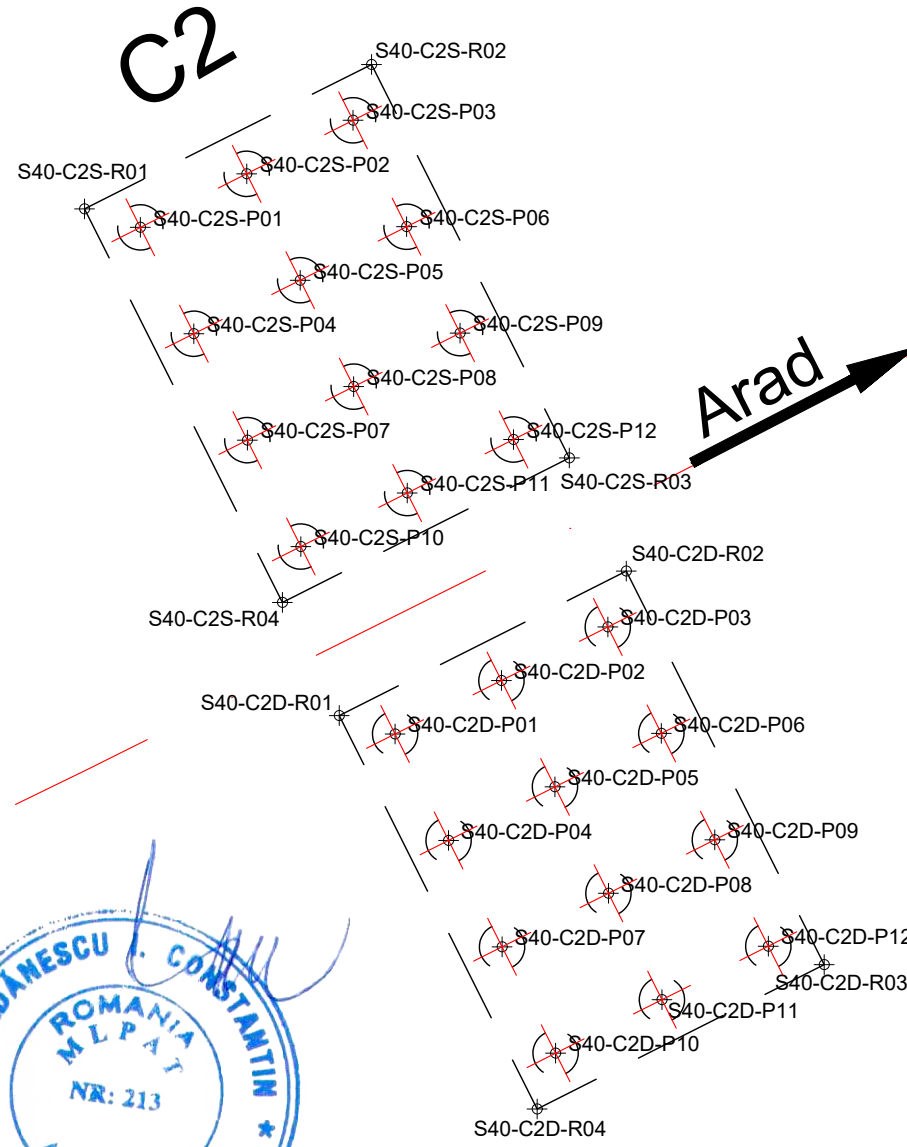
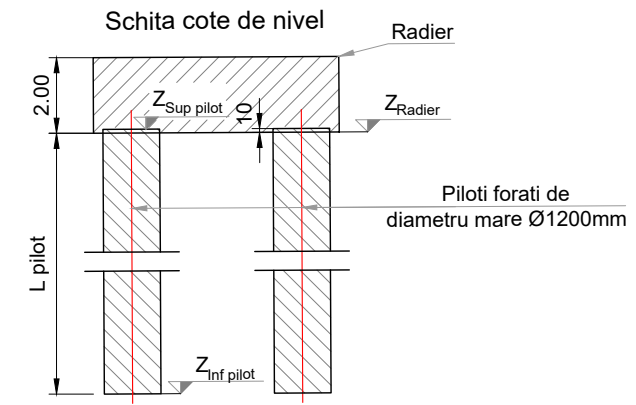

TRASARE RADIER CULEE "C2"-fir stg			
Pct.	X-(EST)	Y-(NORD)	Z
S40-C2S-R01	231591.11	564768.07	91.17
S40-C2S-R02	231591.30	564759.58	91.17
S40-C2S-R03	231579.66	564759.31	91.17
S40-C2S-R04	231579.47	564767.81	91.17

TRASARE PILOTI CULEE "C2"-fir stg				
Pct.	X-(EST)	Y-(NORD)	Zsup	Zinf
S40-C2S-P01	231590.04	564766.95	91.27	64.17
S40-C2S-P02	231590.11	564763.80	91.27	64.17
S40-C2S-P03	231590.18	564760.65	91.27	64.17
S40-C2S-P04	231586.89	564766.88	91.27	64.17
S40-C2S-P05	231586.96	564763.73	91.27	64.17
S40-C2S-P06	231587.03	564760.58	91.27	64.17
S40-C2S-P07	231583.74	564766.81	91.27	64.17
S40-C2S-P08	231583.81	564763.66	91.27	64.17
S40-C2S-P09	231583.88	564760.51	91.27	64.17
S40-C2S-P10	231580.59	564766.74	91.27	64.17
S40-C2S-P11	231580.66	564763.59	91.27	64.17
S40-C2S-P12	231580.73	564760.44	91.27	64.17

TRASARE RADIER CULEE "C2"-fir dr			
Pct.	X-(EST)	Y-(NORD)	Z
S40-C2D-R01	231576.12	564767.74	91.30
S40-C2D-R02	231576.31	564759.24	91.30
S40-C2D-R03	231564.66	564758.98	91.30
S40-C2D-R04	231564.47	564767.48	91.30

TRASARE PILOTI CULEE "C2"-fir dr				
Pct.	X-(EST)	Y-(NORD)	Zsup	Zinf
S40-C2D-P01	231575.04	564766.61	91.40	64.30
S40-C2D-P02	231575.11	564763.46	91.40	64.30
S40-C2D-P03	231575.18	564760.31	91.40	64.30
S40-C2D-P04	231571.89	564766.54	91.40	64.30
S40-C2D-P05	231571.96	564763.39	91.40	64.30
S40-C2D-P06	231572.04	564760.24	91.40	64.30
S40-C2D-P07	231568.74	564766.47	91.40	64.30
S40-C2D-P08	231568.82	564763.32	91.40	64.30
S40-C2D-P09	231568.89	564760.17	91.40	64.30
S40-C2D-P10	231565.60	564766.40	91.40	64.30
S40-C2D-P11	231565.67	564763.25	91.40	64.30
S40-C2D-P12	231565.74	564760.10	91.40	64.30



<b>PROIECTANT / DESIGNER:</b> <b>S.C. CONSTRANS S.R.L.</b>	<b>BENEFICIAR / BENEFICIARY:</b> <b>MUNICIPIUL ARAD, MUNICIPIUL ORADEA, CONSILIUL JUDETEAN ARAD, CONSILIUL JUDETEAN BIHOR CNAIR</b>	<b>FUNCTIA / POSITION:</b> <b>COORDONATOR DE PROIECT / PROJECT MANAGER</b>	<b>NUME / NAME:</b> ing. S. VEACESLAV	<b>SEMNTURA / SIGNATURE:</b> 	<b>Titlu plansa / Drawing title:</b> Plan trasare - plan 12 / 12 Layout plan - drawing 12 / 12	<b>REV. / REV.:</b> R00	<b>DATA / DATE:</b> 11.2023	<b>DETALII REVIZIE / REVISION DETAILS:</b> P.T.E.	<b>PROIECTAT / DESIGNER:</b> ConsiTrans
		<b>INVESTITIA / INVESTMENT:</b> ACTUALIZARE/COMPLETARE/REVIZUIRE (S.F. + P.A.C. + P.O.E + P.T.E.) "DRUM EXPRES ARAD ORADEA" ACTUALIZATION/COMPLETION (S.F. + P.A.C. + P.O.E + P.T.E.) "EXPRESS ROAD ARAD ORADEA"	<b>SEF PROIECT SPECIALITATE / TEAM LEADER:</b> ing. D. COVELTIR			<b>Pod pe DX la km 71+700 peste raul Crisul Alb</b> Bridge on DX at km 71+700 over Crisul Alb river			
	<b>FAZA PROIECTARE / DESIGN STAGE:</b> <b>PROIECT TEHNIC DE EXECUTIE / EXECUTION TECHNICAL PROJECT</b>	<b>PROIECTAT / DESIGNER:</b> ing. V. URDAREANU		<b>LUCRARI DE POD / BRIDGE WORKS</b>					
		<b>Contract /Contract:</b> 14724/01.07.2021 <b>Project /Project no.:</b> 001/2021	<b>Data / Date:</b> 11.2023		<b>Scara /Scale:</b> 1:200	<b>VERIFICAT / INTERNAL CHECKER:</b> ing. D. COVELTIR		<b>Cod plansa / Drawing code:</b> CST-0121-PTE-02-DX- 02-P40-PTR-12-R00	