

MATERIALE

1. Beton cf. CP 012/2007

Element constructiv	Beton	Clasa de expunere	Tasare	A/C	Ciment	Armatura
Beton egalizare	C8/10	XF1	-	-	-	-
Pereu	C25/30	XC4;XF2	S4	0.500	300	-
Piloti	C20/25	XC2	S4	0.60	375	B500SC/BS7500SC
Radier	C30/37	XC4;XF2;XD1	S3	0.55	300	B500SC/BS7500SC
Elevatii	C30/37	XC4;XF2;XD1	S3	0.55	300	B500SC/BS7500SC
Placi racordare / Grinda rezemare	C20/25	XC2	S4	0.60	260	B500SC/BS7500SC
Grinda prefabricata post-tensionata	C45/55	XC4;XD1;XF2	S4	0.40	320	B500SC/BS7500SC
Grinda prefabricata pretensionata	C50/60	XC4;XD1;XF2	S4	0.40	320	B500SC/BS7500SC
Placa suprabetonare / Borduri	C35/45	XC4;XF4;XD3	S3	0.50	340	B500SC/BS7500SC
Predale prefabricate	C35/45	XC4;XD1;XF4	S4	0.50	340	B500SC/BS7500SC
Prefabricat grinda parapet	C35/45	XC4;XD3;XF4	S4	0.45	340	B500SC/BS7500SC

2. Otel

Armatura moale	B500SC/BS7500SC
Armatura pretensionata	TBP Y 1860S7
Otel tablier metallic	S355NL / S355J2+N, echivalent OL52EP

NOTA:
 Intre structurile juxtapuse se vor monta plase de protectie orizontale, conform detaliului alaturat, pe toata lungimea suprastructurii (golului dintre tabliere).
 Protectia anticoroziva a gratarului metallic se va face prin galvanizare profunda executata la cald

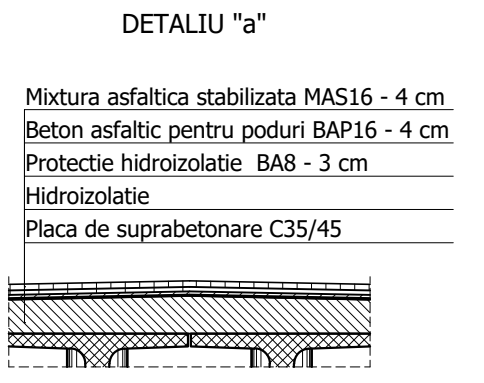
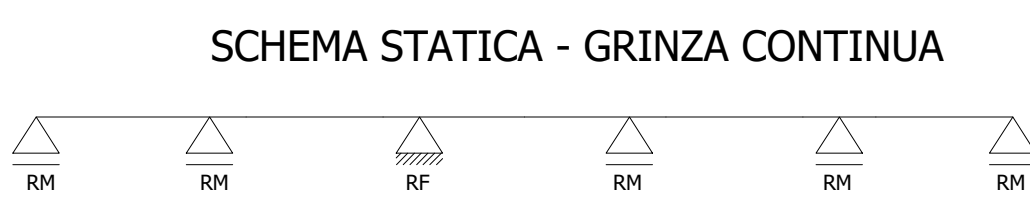
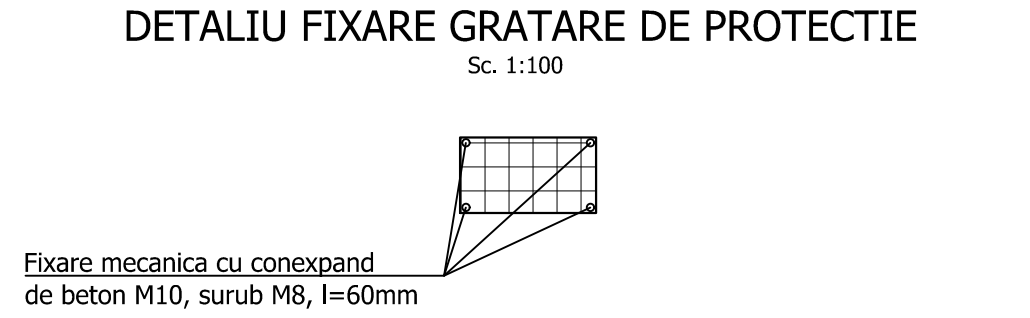
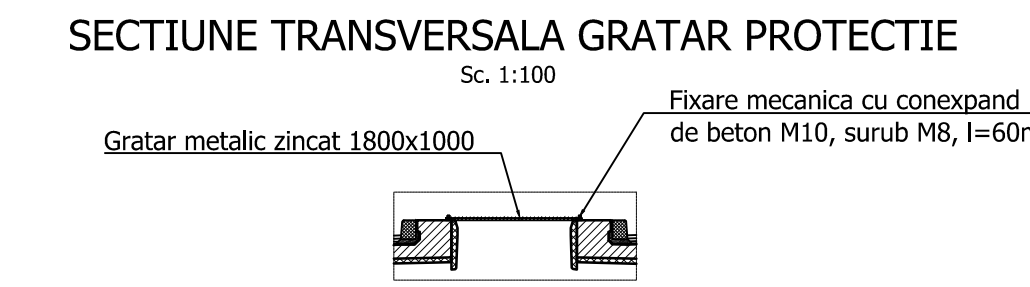

Convoi de calcul: LM1, LM2, conf. SR EN 1991-2/2005
 Categoria de importanta: "B"
 Exigente de verificare: A4, B2, D
 Parametri seismici: a_y=0.35g, T_c=1.00s conf. cod P100/1-2013, SR EN 1998-2/2006

FORAJ GEOTEHNIC F013

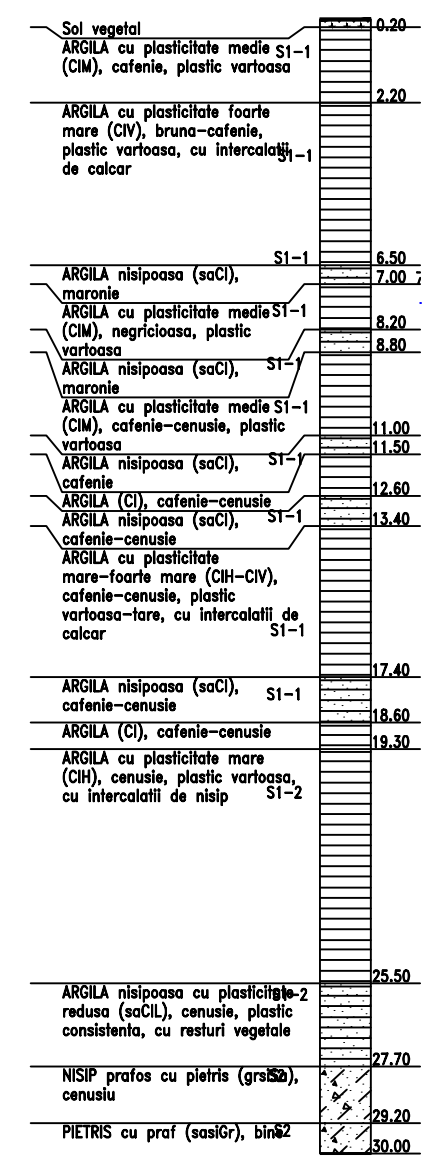

PROIECT CO-FINANAT DE UNIUNEA EUROPEANA PRIN PROGRAMUL OPERATIONAL INFRASTRUCTURA MARE

UNIUNEA EUROPEANA
 GUVERNUL ROMANIEI

AMPLASAMENT

BENEFICIAR
 MINISTERUL TRANSPORTURILOR SI INFRASTRUCTURII
 COMPANIA NATIONALA DE ADMINISTRARE A INFRASTRUCTURII RUTIERE

PROIECTANT GENERAL
acciona

SUBPROIECTANT

INVESTITIA
 ELABORARE STUDII DE FEZABILITATE SI PROIECT TEHNIC DE EXECUTIE PENTRU OBIECTIVUL DRUM EXPRES FOCSANI - BRAILA

FAZA DE PROIECTARE
 Studiu de Fezabilitate

Coordonator de proiect
 Ing. José Carlos RUBIO MATILLA

Proiectat
 Ing. VELEA Cornel

Verificat
 Ing. Drăgăș - Florin VOIȚESCU

Proiect nr:
 92/37074/19.06.2020

Scara: 1:500 / 1:200
 Data: IANUARIE 2024

Pasaj pe DX peste DN23A km 5+272
 DISPOZITIE GENERALA - SOL 2

Cod: FB-SF-LI-STR-ST03-DG-001 Rev. 03