

NOTA:  
Intre structurile juxtapuse se vor monta plase de protectie orizontale, conform detaliului alaturat, pe toata lungimea suprastructurii (golului dintre tabliere)  
Protectia anticoroziva a gratarului metalic se va face prin galvanizare profunda executata la cald

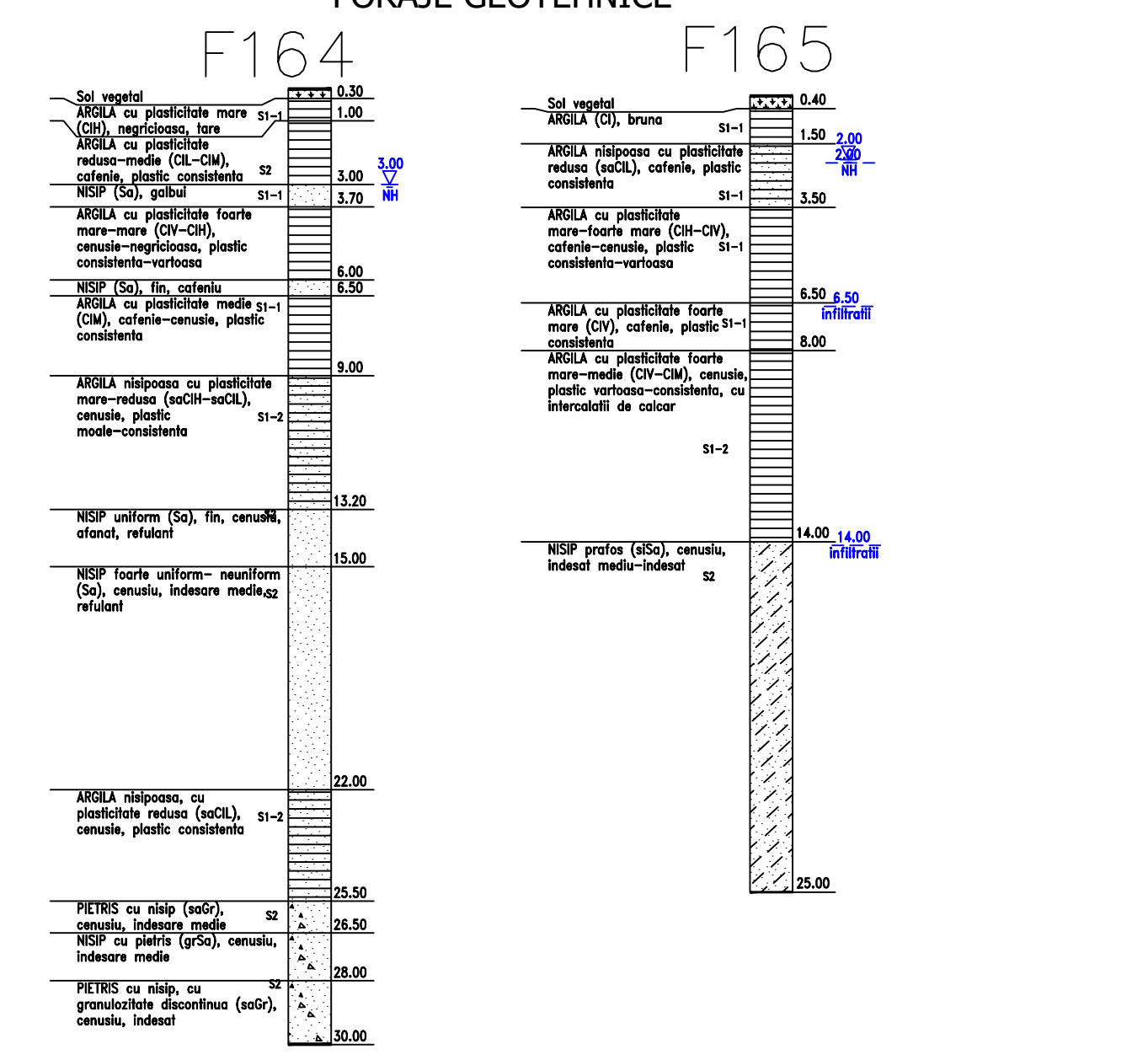
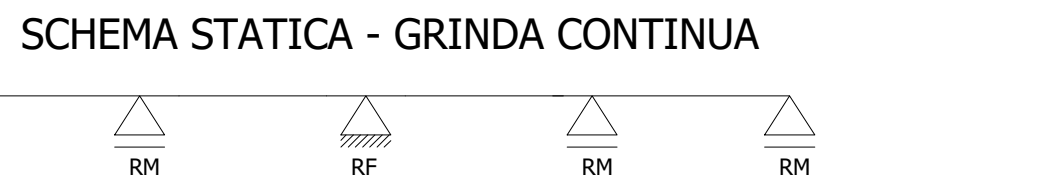
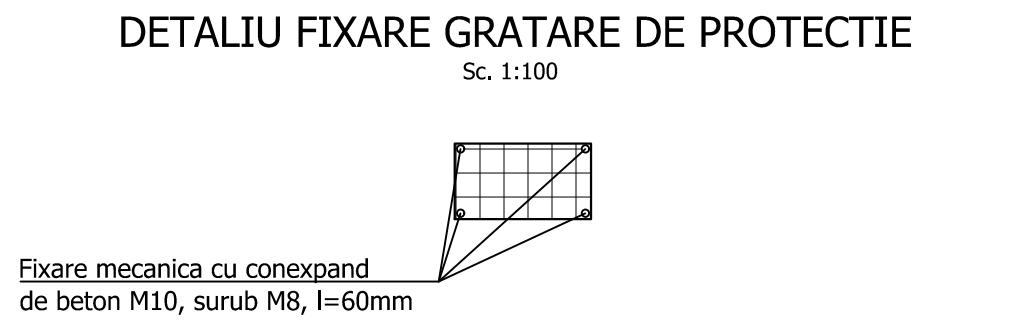
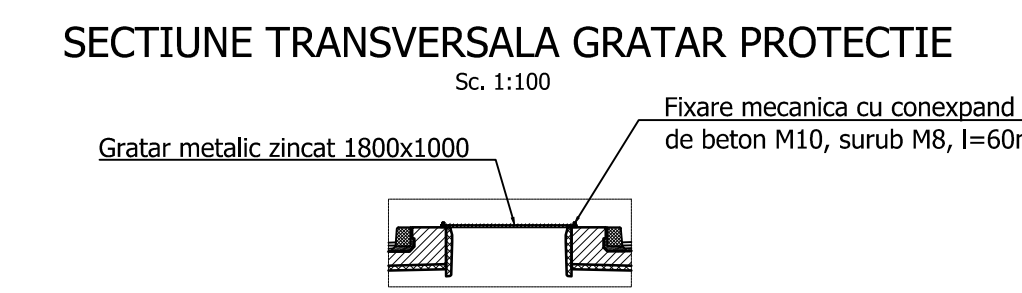
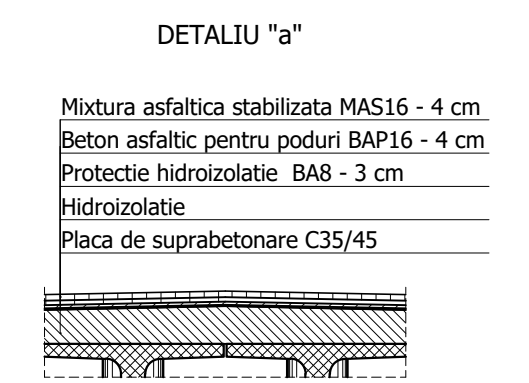

**MATERIALE**

1. Beton cf. CP 012/2007

Element constructiv	Beton	Clasa de expunere	Tasare	A/C	Ciment	Armatura
Beton egalizare	C8/10	XF1	-	-	-	-
Pereu	C25/30	XC4;XF2	S4	0.500	300	-
Piloti	C20/25	XC2	S4	0.60	375	B500SC/BST500SC
Radier	C30/37	XC4;XF2;XD1	S3	0.55	300	B500SC/BST500SC
Elevatii	C35/45	XC4;XF2;XD3	S3	0.50	320	B500SC/BST500SC
Placi racordare / Grinda rezemare	C20/25	XC2	S4	0.60	260	B500SC/BST500SC
Grinda prefabricata post-tensionata	C45/55	XC4;XD1;XF2	S4	0.40	320	B500SC/BST500SC
Grinda prefabricata pretensionata	C50/60	XC4;XD1;XF2	S4	0.40	320	B500SC/BST500SC
Placa suprabetonare / Borduri	C35/45	XC4;XF4;XD3	S3	0.50	340	B500SC/BST500SC
Predale prefabricate	C35/45	XC4;XD1;XF4	S4	0.50	340	B500SC/BST500SC
Prefabricat grinda parapet	C35/45	XC4;XD3;XF4	S4	0.45	340	B500SC/BST500SC

2. Otel

Armatura moale	B500SC/BST500SC
Armatura pretensionata	TBP Y 1860S7
Otel tablier metalic	S355NL / S355J2+N, echivalent OL52EP

PROIECT CO-FINANAT DE UNIUNEA EUROPEANA PRIN PROGRAMUL OPERATIONAL INFRASTRUCTURA MARE

UNIUNEA EUROPEANA

GUVERNUL ROMANIEI

AMPLASAMENT

BENEFICIAR

MINISTERUL TRANSPORTURILOR SI INFRASTRUCTURII

COMPANIA NATIONALA DE ADMINISTRARE A INFRASTRUCTURII RUTIERE

PROIECTANT GENERAL

acciona

SUBPROIECTANT

INVESTITIA

ELABORARE STUDIU DE FEZABILITATE SI PROIECT TEHNIC DE EXECUTIE PENTRU OBIECTIVUL DRUMI EXPRES FOCSANI - BRAILA

FAZA DE PROIECTARE

Studiu de Fezabilitate

Coordonator de proiect

ing. José Carlos RUBIO MATILLA

Proiectat

ing. VELEA Cornel

Verificat

ing. Dragos Florin VULPESCU

Proiect nr:

92/37074/19.06.2020

Scara:

1:500 / 1:200

Data:

IANUARIE 2024

Pasaj pe DX peste DJ202A

km 41+200

DISPOZITIE GENERALA - Solutia 2

Cod: FB-SF-L2-STR-ST30-DG-001

Rev. 03